

# INSTALLATION MANUAL



DB68-03340A-06

Please read 'Safety Precautions' described in the installation manual of the air conditioner.

- Check the following parts in the package.
- For further information of the piping material and size of the refrigerant pipes, refer to the installation manual of the air conditioner.



This marking on the product, accessories or literature indicates that the product and its electronic accessories (e.g. charger, headset, USB cable) should not be disposed of with other household waste. For correct disposal of this product, please visit <http://www.samsung.com/weee.pdf>

## Requirement

- Condensate may occur on the heat insulation surface according to the atmosphere inside of the ceiling.
- If the inside of the ceiling has high temperature or humidity rate is more than 80%, please add proper insulation to prevent water drops.
- The stopper area of the pipe or socket should be spread with a welding material. EX

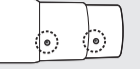

## Branch joints

### Y-joint

Name	Model	MXJ-YA1509M	MXJ-YA2512M	MXJ-YA2812M	MXJ-YA2815M	MXJ-YA3419M	MXJ-YA4119M	MXJ-YA4422M
Liquid side								
Gas side								

### Reducer

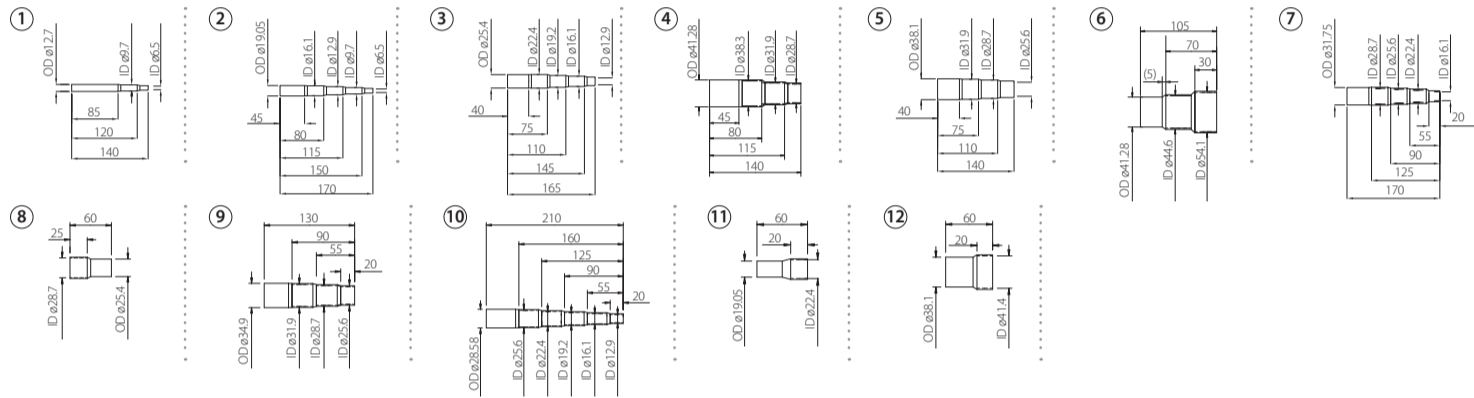

Model name	Total indoor unit's capacities
MXJ-YA1509M	15.0 kW (51 MBH) and below
MXJ-YA2512M	Over 15.0~40.0 kW (51~136 MBH) and below
MXJ-YA2812M	Over 40.0~45.0 kW (136~154 MBH) and below
MXJ-YA2815M	Over 45.0~70.3 kW (154~240 MBH) and below
MXJ-YA3419M	Over 70.3~98.4 kW (240~336 MBH) and below
MXJ-YA4119M	Over 98.4~135.2 kW (336~461 MBH) and below
MXJ-YA4422M	Over 135.2 kW (461 MBH)

### Y-joint for HR (High pressure gas)

Model	MXJ-YA1500M	MXJ-YA2500M	MXJ-YA3100M	MXJ-YA3800M
Liquid side				
Gas side				

### Reducer

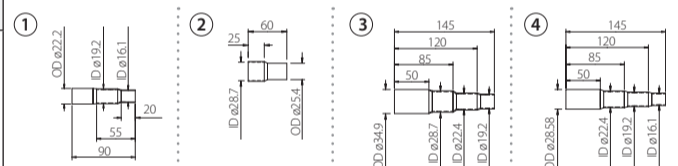

Model name	Total indoor unit's capacities
MXJ-YA1500M	22.4 kW (76 MBH) and below
MXJ-YA2500M	Over 22.4~70.3 kW (76~240 MBH) and below
MXJ-YA3100M	Over 70.3~135.2 kW (240~461 MBH) and below
MXJ-YA3800M	Over 135.2 kW (461 MBH)

### Header joint

Name	Model	MXJ-HA2512M	MXJ-HA3115M	MXJ-HA3819M
Liquid side				
Gas side				

### Reducer

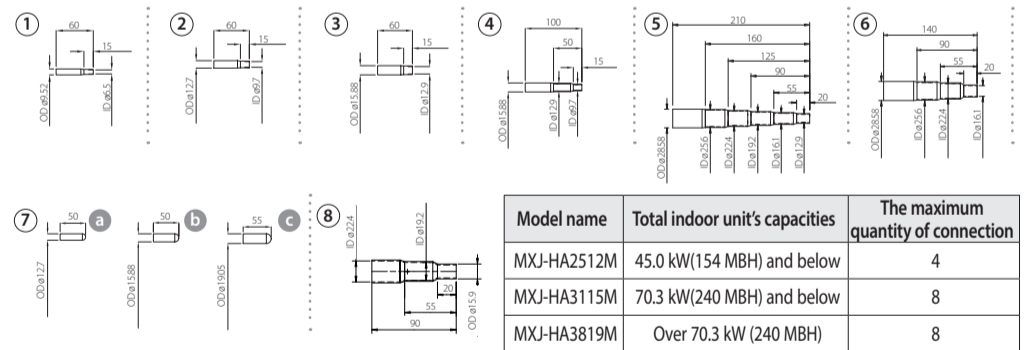

Model name	Total indoor unit's capacities	The maximum quantity of connection
MXJ-HA2512M	45.0 kW(154 MBH) and below	4
MXJ-HA3115M	70.3 kW(240 MBH) and below	8
MXJ-HA3819M	Over 70.3 kW (240 MBH)	8

### Outdoor joint

Name	Model	MXJ-TA3819M	MXJ-TA3419M	MXJ-TA4422M	MXJ-TA4122M
Liquid side					
Gas side					

### Reducer

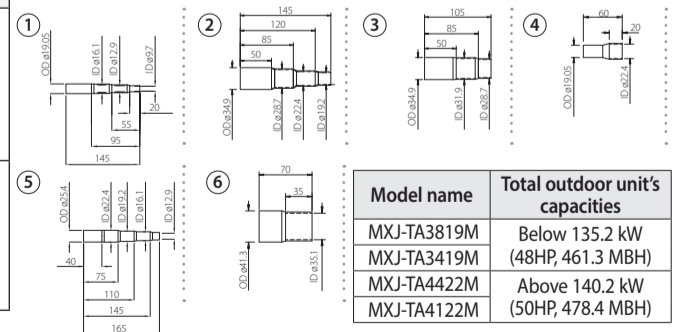

Model name	Total outdoor unit's capacities
MXJ-TA3819M	Below 135.2 kW (48HP, 461.3 MBH)
MXJ-TA4422M	Above 140.2 kW (50HP, 478.4 MBH)

### Outdoor joint for HR (High pressure gas)

Model	MXJ-TA3100M	MXJ-TA3800M
Liquid side		
Gas side		

### Reducer

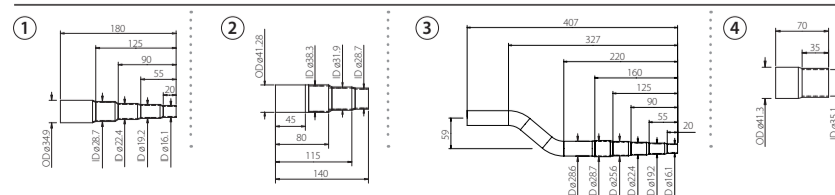

Model name	Total outdoor unit's capacities
MXJ-TA3100M	Below 135.2 kW(48HP, 461.3MBH)
MXJ-TA3800M	Above 140.2 kW(50HP, 478.4 MBH)

# Connecting Method

## Installing the Y-joint

Install the Y-joint 'horizontally' or 'vertically'.

### <Install horizontally>

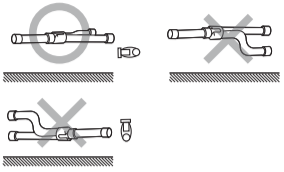

### <Using reducer> \* Not applicable to MXJ-YA1509M\*

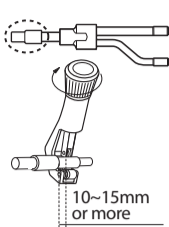

- Use connection part of Y-joint or provided reducer by cutting them in accordance with diameter of connecting pipe.
- Make certain 10~15mm or more for reducer which connected with pipe.
- Remove burr on cut part of reducer.
- It is impossible to connect reducer with pipe, if pipe is deformed or reducer is untrimmed.

**CAUTION**  
◆ **Keep a minimum distance of 500mm or more before connecting a branch joint.**

### <Install vertically>

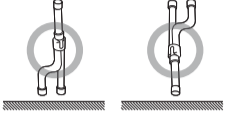

### <How to use a branch joint> \* Applicable to the MXJ-YA1509M model only \*

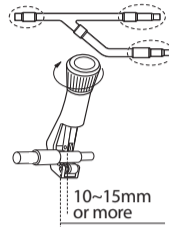

- Before connecting a Y-joint or reducer to the pipe, cut the connection part to fit the diameter of the pipe.
- When cutting the connection part, make sure the part to be connected to the pipe is at least 10~15 mm.
- Remove any burrs on the cross-section of the Y-joint or reducer.
- It is not possible to connect the Y-joint or reducer to the pipe if burrs are not removed completely from the cross-section or if the pipe has been deformed.

**CAUTION**  
◆ **Ensure a minimum straight-line distance of 500 mm before connecting a branch joint.**  
◆ **Do not insert the pipe deeply into the Y-joint or reducer. (Make sure the depth of insertion does not exceed 70mm.)**  
◆ **After connecting a branch joint, connect the part in the straight-line direction to the main pipe. (Applicable model : MXJ-YA1509M\*)**

### <Insertion depth of the connecting pipe>

\* Basic specification

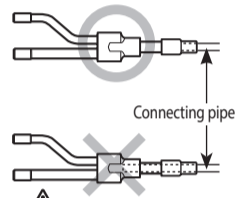

\* When cutting the connection part

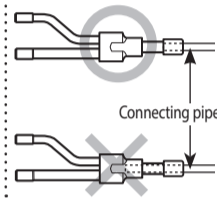

**CAUTION**  
◆ **Do not insert the pipe deeply into the Y-joint. (Do not insert more than 70mm.)**

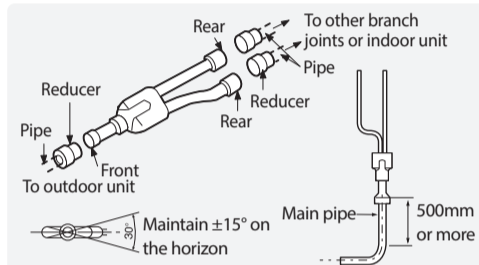

\* Install the Y-joint within ±15° on the horizon or on the vertical.

## Installing the Header joint

1. Select the reducer fitted on the diameter of the pipe.

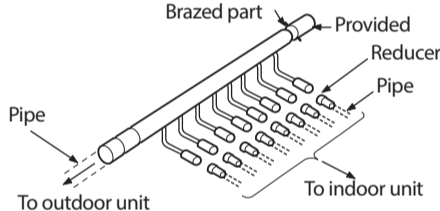

<Liquid side>

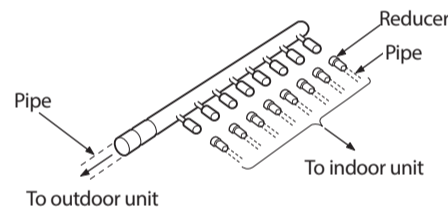

<Gas side>

2. Block the reducer that is not used by brazing the cap if the number of connected indoor unit is fewer than header joint holes.

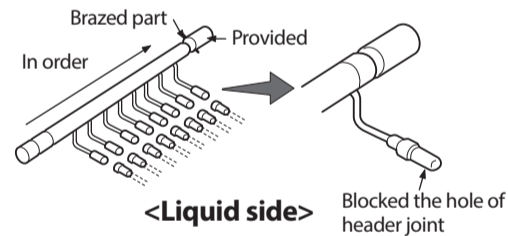

<Liquid side>

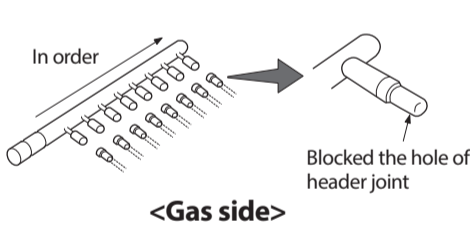

<Gas side>

**Note** Connect the header joint to the pipe by cutting the provided reducer properly.

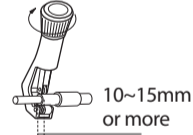
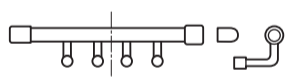

**CAUTION**  
◆ **Connect the header joint in order respecting the number of the indoor unit.**  
◆ **Connect the indoor unit as the highest capacity comes first.**

3. Install the header joint horizontally.

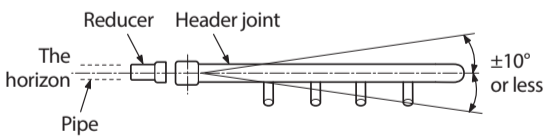

<Liquid side>

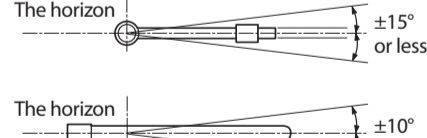

<Gas side>

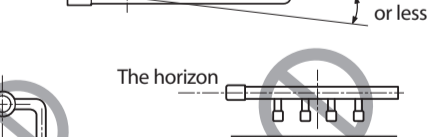
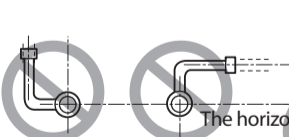
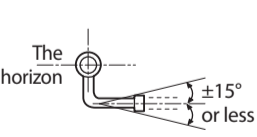

## Installing the Outdoor joint

\* Use the attached reducer according to the selected pipe size.

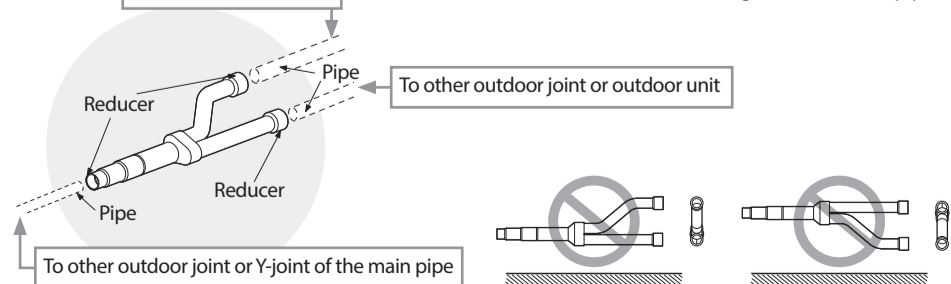

<Liquid side>

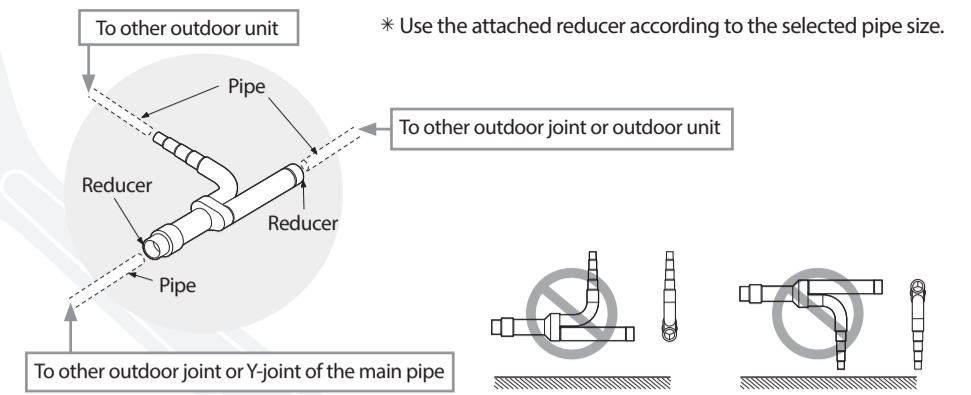

<Gas side>

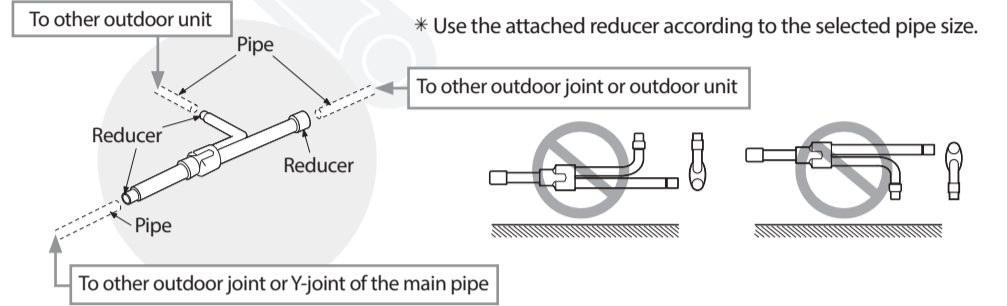

<High pressure gas side>

**Note** Connect the Outdoor joint to the pipe by cutting the outlet of the Outdoor joint or provided reducer properly.

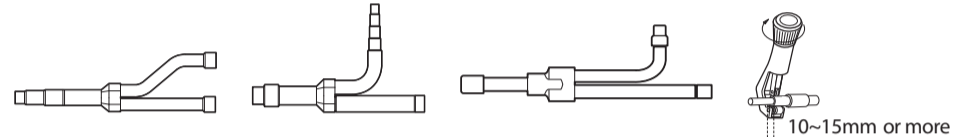

### Installation of outdoor joints

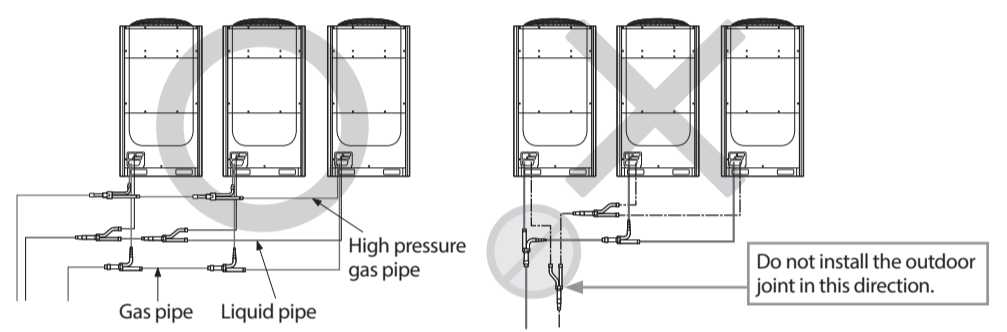

\* High pressure gas pipe only applies to the HR product.

## Insulating the branch joint

### Y-joint & liquid side & gas side of the outdoor unit

- ◆ Attach the insulation provided with a branch joint to the insulation supplied in the field without a gap. Wrap the connected part with an insulation (Field supply) of a thickness of at least 10mm.
- ◆ Use an insulation with the heat resisting temperature over 120°C. Wrap the branch joint with an insulation of a thickness of at least 10mm.
- ◆ When insulating in high humidity (higher than 30°C, 80%), wrap the supplied insulation with more than 10mm of extra insulation such as Polyethylene Foam or other similar material.
- ◆ Wrap the connected part between the Outdoor joint and the gas side of the outdoor unit to prevent it from defrosting. Wrap gas side pipe of the outdoor unit wholly to prevent it from dewing.

\* Not applicable to MXJ-YA1509M\*

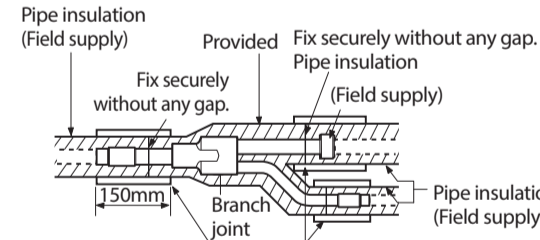

A thickness of the insulation (Field supply) should be at least 10mm.

\* Attach the adhesive insulation tape to the pipe as shown in the picture after insulating the pipe.

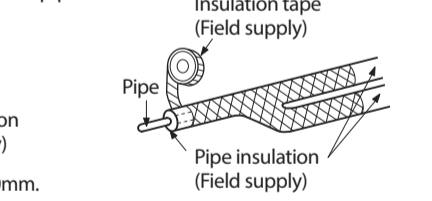

\* Applicable to the MXJ-YA1509M model only \*

Make sure the area where the supplied insulation and the (Field supply) pipe insulation meet is securely fastened without any gaps.

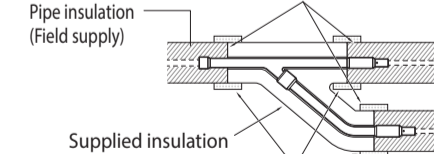

Make sure the thickness of the insulation (Field supply) is at least 10mm.

\* After insulating the pipe, attach adhesive insulation tape, as shown in the picture.

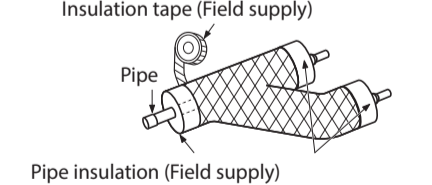

## Header joint

- ◆ Cover the connected part and fasten the header joint using a cable tie.
- ◆ Insulate the header joint and the brazed part and wrap the connected part with an adhesive insulation tape to prevent it from dewing.

