

**SAMSUNG**

# VRF

# Technical Data Book

Indoor Units for Europe  
(R32, HP)



Model : AM\*\*\*DN\*\*KG/EU, AM\*\*\*HE\*\*KG\*EU

# History

---

Version	Modification	Date	Remark
Ver.1.0	Released VRF Indoor Units for Europe (R32, Heat Pump) TDB	24.06.04	
Ver.1.1	Updated the final Spec.	24.09.02	
Ver.2.0	Updated new line up	25.04.24	

# Nomenclature

## Indoor Unit

### Model Name

<b>AM</b>	<b>028</b>	<b>D</b>	<b>N</b>	<b>4</b>	<b>D</b>	<b>K</b>	<b>G</b>	/	<b>EU</b>
(1)	(2)	(3)	(4)	(5)	(6)	(7)	(8)		Buyer

#### (1) Classification

<b>AM</b>	DVM
-----------	-----

#### (2) Capacity

X 100 Watt (3 digits)
-----------------------

#### (3) Version

<b>D</b>	2024
<b>H</b>	2026

#### (4) Product Type

<b>N, E</b>	Indoor Unit
-------------	-------------

#### (5) Product Notation

<b>1</b>	(WindFree™) 1Way Cassette
<b>N</b>	(WindFree™) 4Way Cassette (600x600)
<b>4</b>	(WindFree™) 4Way Cassette
<b>6</b>	360 Cassette
<b>L</b>	LSP Duct
<b>M</b>	MSP Duct
<b>H</b>	HSP Duct
<b>V</b>	WindFree™ QMD
<b>Q</b>	MAX
<b>C</b>	CEILING
<b>J</b>	Console
<b>E</b>	OAP Duct
<b>K</b>	ERV Plus
<b>F</b>	Floor Standing
<b>P</b>	PAC
<b>B</b>	Hydro HE

#### (6) Feature

<b>F</b>	Flagship
<b>D</b>	Deluxe

#### (7) Rating Voltage

<b>K</b>	220~240V, 50/60Hz, 1Ø
----------	-----------------------

#### (8) Mode

<b>G</b>	Heat Pump (R32)
----------	-----------------

# Contents

---

WindFree™ 1Way Cassette	5
WindFree™ 4Way Cassette (600x600)	29
WindFree™ 4Way Cassette	49
360 Cassette	86
LSP Duct	113
MSP Duct	151
HSP Duct	196
OAP Duct	229
Wall-mounted	248
Ceiling	278
Console	298
Floor Standing	TBD
PAC	315
ERV Plus	TBD
Hydro unit	TBD

---

# WindFree™ 1Way Cassette



---

1. Specification	7
2. Summary Table	11
3. Capacity Table	12
4. Dimensional Drawing	13
5. Center of Gravity	16
6. Electrical Wiring Diagram	17
7. Sound Data	18
8. Temperature and air flow distribution	22
9. Piping Diagram	28

---

# Line-up

## WindFree™ 1Way Cassette

Capacity (kW)					
1.7	2.2	2.8	3.6	5.6	7.1
					

# 1. Specification

## WindFree™ 1Way Cassette

Model Name				AM017DN1DKG/EU	AM022DN1DKG/EU	AM028DN1DKG/EU
Power Supply			Φ, #, V, Hz	1,2,220-240,50/60	1,2,220-240,50/60	1,2,220-240,50/60
Performance	Capacity	Cooling	kW	1.70	2.20	2.80
			Btu/h	5,800	7,500	9,600
		Heating	kW	1.90	2.50	3.20
			Btu/h	6,500	8,500	10,900
Power	Power Input	Cooling	W	24.00	25.00	50.00
				Heating	24.00	25.00
	Current Input	Cooling	A		0.14	0.15
				Heating	0.14	0.15
	Current	MCA	A		0.18	0.18
		MFA		15	15	15
Heat exchanger	Type		-	Fin & Tube	Fin & Tube	Fin & Tube
	Material	Fin	-	Al	Al	Al
		Tube	-	Cu	Cu	Cu
	Fin Treatment		-	Green Hydrophile	Green Hydrophile	Green Hydrophile
Fan	Type		-	Crossflow Fan	Crossflow Fan	Crossflow Fan
	Quantity		ea	1	1	1
	Air Flow Rate	H/M/L	m <sup>3</sup> /min	4.80/4.30/4.10	5.10/4.60/4.30	7.00/6.00/5.00
			l/s	80.00/71.67/68.33	85.00/76.67/71.67	116.67/100.00/83.33
Fan Motor	Model		-	BLDC Motor	BLDC Motor	AC Motor
	Output x n		W	27 x 1	27 x 1	23 x 1
Piping Connections	Liquid Pipe		Type	Flare Connection	Flare Connection	Flare Connection
			Φ, mm	6.35	6.35	6.35
			Φ, inch	1/4	1/4	1/4
	Gas Pipe		Type	Flare Connection	Flare Connection	Flare Connection
			Φ, mm	12.7	12.7	12.7
			Φ, inch	1/2	1/2	1/2
Drain Pipe		Φ, mm	VP25 (OD 32,ID 25)	VP25 (OD 32,ID 25)	VP25 (OD 32,ID 25)	
Wiring connections	Communication	Minimum	mm <sup>2</sup>	0.75	0.75	0.75
		Remark	-	F1, F2	F1, F2	F1, F2
Refrigerant	Type		-	R32	R32	R32
	Electronic Expansion Valve		-	EEV INCLUDED	EEV INCLUDED	EEV INCLUDED
Sound	Sound Pressure	High/Mid/Low/WindFree	dB(A)	28 / 26 / 24 / 24	29 / 26 / 24 / 24	32 / 28 / 24 / 24
	Sound Power	Cooling		46	47	50
Dimension	Net Weight		kg	8.0	8.0	10.0
	Shipping Weight		kg	10.5	10.5	12.8
	Net Dimensions (WxHxD)		mm	740 x 135 x 360	740 x 135 x 360	970 x 135 x 410
	Shipping Dimensions (WxHxD)		mm	895 x 223 x 435	895 x 223 x 435	1,173 x 231 x 487

# 1. Specification

## WindFree™ 1Way Cassette

Model Name			AM017DN1DKG/EU	AM022DN1DKG/EU	AM028DN1DKG/EU
Casing	Material	-	ABS	ABS	ABS
Panel	Model Name	-	PC1MWFMANW	PC1MWFMANW	PC1NWFMANW
	Type	-	Wind Free	Wind Free	Wind Free
	Material	-	HIPS	HIPS	HIPS
	Color	-	White	White	White
	Net Weight	kg	2.6	2.6	4.3
	Shipping Weight	kg	3.8	3.8	6.3
	Net Dimensions (W×H×D)	mm	960 x 34 x 420	960 x 34 x 420	1,198 x 34 x 500
	Shipping Dimensions (W×H×D)	mm	1,003 x 112 x 482	1,003 x 112 x 482	1,262 x 122 x 566
Drain pump		-	INCLUDED	INCLUDED	INCLUDED
	Max. lifting Height / Displacement	mm / Liter/h	750 / 24	750 / 24	750 / 24

### NOTE

- Cooling : Indoor temperature 27°C DB / 19°C WB, Outdoor temperature 35°C DB/24°C WB, Refrigerant pipe length 7.5m, Level difference 0m.
- Heating : Indoor temperature 20°C DB / 15°C WB, Outdoor temperature 7°C DB / 6°C WB, Refrigerant pipe length 7.5m, Level difference 0m.
- Sound level was acquired in an anechoic room. Thus actual noise level may be different depending on the installation conditions.
- These products contain R32 (GWP=675) which is fluorinated greenhouse gas.
- Specifications may be subject to change without prior notice.
- Select wire size based on the value of MCA
- Drain pump included (check valve included)

# 1. Specification

## WindFree™ 1Way Cassette

Model Name				AM036DN1DKG/EU	AM056DN1DKG/EU	AM071DN1DKG/EU
Power Supply			Φ, #, V, Hz	1,2,220-240,50/60	1,2,220-240,50/60	1,2,220-240,50/60
Performance	Capacity	Cooling	kW	3.60	5.60	7.10
			Btu/h	12,300	19,100	24,200
		Heating	kW	4.00	6.30	8.00
			Btu/h	13,600	21,500	27,300
Power	Power Input	Cooling	W	50.00	55.00	80.00
		Heating		50.00	55.00	80.00
	Current Input	Cooling	A	0.25	0.28	0.40
		Heating		0.25	0.28	0.40
	Current	MCA	A	0.31	0.35	0.50
		MFA		15	15	15
Heat exchanger	Type		-	Fin & Tube	Fin & Tube	Fin & Tube
	Material	Fin	-	Al	Al	Al
		Tube	-	Cu	Cu	Cu
	Fin Treatment		-	Green Hydrophile	Green Hydrophile	Green Hydrophile
Fan	Type		-	Crossflow Fan	Crossflow Fan	Crossflow Fan
	Quantity		ea	1	1	1
	Air Flow Rate	H/M/L	m <sup>3</sup> /min	8.00/7.00/6.00	16.00/14.00/12.50	17.00/15.50/14.00
			l/s	133.33/116.67/100.00	266.67/233.33/208.33	283.33/258.33/233.33
Fan Motor	Model		-	AC Motor	BLDC Motor	BLDC Motor
	Output x n		W	23 x 1	54 x 1	54 x 1
Piping Connections	Liquid Pipe		Type	Flare Connection	Flare Connection	Flare Connection
			Φ, mm	6.35	6.35	9.52
			Φ, inch	1/4	1/4	3/8
	Gas Pipe		Type	Flare Connection	Flare Connection	Flare Connection
			Φ, mm	12.7	12.70	15.88
			Φ, inch	1/2	1/2	5/8
Drain Pipe		Φ, mm	VP25 (OD 32,ID 25)	VP25 (OD 32,ID 25)	VP25 (OD 32,ID 25)	
Wiring connections	Communication	Minimum	mm <sup>2</sup>	0.75	0.75	0.75
		Remark	-	F1, F2	F1, F2	F1, F2
Refrigerant	Type		-	R32	R32	R32
	Electronic Expansion Valve		-	EEV INCLUDED	EEV INCLUDED	EEV INCLUDED
Sound	Sound Pressure	High/Mid/Low/WindFree	dB(A)	37 / 33 / 30 / 30	41 / 38 / 35 / 30	42 / 39 / 36 / 31
	Sound Power	Cooling		55	59	60
Dimension	Net Weight		kg	10.0	13.5	13.5
	Shipping Weight		kg	12.8	17.3	17.3
	Net Dimensions (WxHxD)		mm	970 x 135 x 410	1,200 x 138 x 450	1,200 x 138 x 450
	Shipping Dimensions (WxHxD)		mm	1,173 x 231 x 487	1,435 x 224 x 525	1,435 x 224 x 525

# 1. Specification

## WindFree™ 1Way Cassette

Model Name			AM036DN1DKG/EU	AM056DN1DKG/EU	AM071DN1DKG/EU
Casing	Material	-	ABS	ABS	ABS
Panel	Model Name	-	PC1NWFMANW	PC1BWFMANW	PC1BWFMANW
	Type	-	Wind Free	Wind Free	Wind Free
	Material	-	HIPS	HIPS	HIPS
	Color	-	White	White	White
	Net Weight	kg	4.3	5.0	5.0
	Shipping Weight	kg	6.3	7.0	7.0
	Net Dimensions (W×H×D)	mm	1,198 x 34 x 500	1,410 x 34 x 500	1,410 x 34 x 500
	Shipping Dimensions (W×H×D)	mm	1,262 x 122 x 566	1,474 x 122 x 566	1,474 x 122 x 566
Drain pump		-	INCLUDED	INCLUDED	INCLUDED
	Max. lifting Height / Displacement	mm / Liter/h	750 / 24	750 / 24	750 / 24

### NOTE

- Cooling : Indoor temperature 27°C DB / 19°C WB, Outdoor temperature 35°C DB/24°C WB, Refrigerant pipe length 7.5m, Level difference 0m.
- Heating : Indoor temperature 20°C DB / 15°C WB, Outdoor temperature 7°C DB / 6°C WB, Refrigerant pipe length 7.5m, Level difference 0m.
- Sound level was acquired in an anechoic room. Thus actual noise level may be different depending on the installation conditions.
- These products contain R32 (GWP=675) which is fluorinated greenhouse gas.
- Specifications may be subject to change without prior notice.
- Select wire size based on the value of MCA
- Drain pump included (check valve included)

## 2. Summary Table

### WindFree™ 1Way Cassette

#### Performance Characteristics

Model Code	Net Weight (kg)	Fan Speed	Nominal Capacity(kW)			Airflow (CMM)	Sound Pressure (dBA)	Sound Power (dBA)
			Cooling	Sensible	Heating			
AM017DN1DKG/EU	8.0	High	1.70	1.20	1.90	4.8	28	46
		Mid	1.50	1.10	1.80	4.3	26	-
		Low	1.50	1.10	1.80	4.1	24	-
		W/Free	1.00	0.70	-	2.0	24	-
AM022DN1DKG/EU	8.0	High	2.20	1.50	2.50	5.1	29	47
		Mid	2.00	1.40	2.40	4.6	26	-
		Low	1.90	1.30	2.30	4.3	24	-
		W/Free	1.20	0.90	-	2.0	24	-
AM028DN1DKG/EU	10.0	High	2.80	1.90	3.20	7.0	32	50
		Mid	2.40	1.60	3.00	6.0	28	-
		Low	2.10	1.40	2.70	5.0	24	-
		W/Free	1.40	1.00	-	3.2	24	-
AM036DN1DKG/EU	10.0	High	3.60	2.6	4.00	8.0	37	55
		Mid	3.20	2.30	3.70	7.0	33	-
		Low	2.80	2.00	3.50	6.0	30	-
		W/Free	1.90	1.30	-	3.6	30	-
AM056DN1DKG/EU	13.5	High	5.60	4.20	6.30	16.0	41	59
		Mid	5.00	3.80	5.90	14.0	38	-
		Low	4.50	3.40	5.60	12.5	35	-
		W/Free	3.00	2.10	-	6.0	30	-
AM071DN1DKG/EU	13.5	High	7.0	5.00	8.00	17.0	42	60
		Mid	6.60	4.60	7.60	15.5	39	-
		Low	6.00	4.20	7.30	14.0	36	-
		W/Free	4.00	2.80	-	6.5	31	-

#### NOTE

- Sound data is based on cooling operation.

#### Electrical Characteristics

Model Code	Power Supply (Φ, #, V, Hz)	Power Input (W)	Current Input (A)	MCA (A)	MFA (A)	FLA (A)
AM017DN1DKG/EU	1,2,220-240,50/60	24.00	0.14	0.18	15	0.14
AM022DN1DKG/EU	1,2,220-240,50/60	25.00	0.15	0.18	15	0.15
AM028DN1DKG/EU	1,2,220-240,50/60	50.00	0.23	0.29	15	0.17
AM036DN1DKG/EU	1,2,220-240,50/60	50.00	0.25	0.31	15	0.20
AM056DN1DKG/EU	1,2,220-240,50/60	55.00	0.28	0.35	15	0.28
AM071DN1DKG/EU	1,2,220-240,50/60	80.00	0.40	0.50	15	0.40

#### NOTE

- MCA: Minimum circuit amperes
- MFA: Maximum fuse amperes
- FLA: Full load amperes
- Select wire size based on the value of MCA

# 3. Capacity Table

## WindFree™ 1Way Cassette

### Cooling

TC : Total Capacity, SHC : Sensible Heat Capacity

Model	Outdoor temperature (°C, DB)	Indoor temperature (°C, DB / WB)													
		20 / 14		23 / 16		26 / 18		27 / 19		28 / 20		30 / 22		32 / 24	
		TC	SHC	TC	SHC	TC	SHC	TC	SHC	TC	SHC	TC	SHC	TC	SHC
		kW	kW	kW	kW	kW	kW	kW	kW	kW	kW	kW	kW	kW	kW
1.7	35	1.20	1.00	1.40	1.10	1.60	1.20	1.70	1.20	1.80	1.20	1.80	1.20	2.00	1.10
2.2	35	1.50	1.30	1.80	1.40	2.10	1.50	2.20	1.50	2.30	1.50	2.40	1.50	2.60	1.40
2.8	35	1.90	1.60	2.30	1.80	2.60	1.90	2.80	1.90	2.90	1.90	3.10	1.90	3.30	1.80
3.6	35	2.50	2.20	2.90	2.40	3.40	2.40	3.60	2.60	3.70	2.60	4.00	2.60	4.20	2.40
5.6	35	3.90	3.30	4.60	3.80	5.30	4.10	5.60	4.20	5.80	4.20	6.20	4.20	6.60	4.00
7.1	35	4.90	4.00	5.80	4.50	6.70	4.80	7.10	5.00	7.40	5.00	7.90	5.00	8.40	4.80

### Heating

TC : Total Capacity (kW)

Model	Outdoor temperature (°C, DB)		Indoor temperature (°C, DB)				
			16.0	18.0	20.0	22.0	24.0
			TC	TC	TC	TC	TC
	DB	WB	kW	kW	kW	kW	kW
1.7	7	6	2.10	2.10	1.90	1.70	1.70
2.2	7	6	2.80	2.70	2.50	2.30	2.20
2.8	7	6	3.30	3.20	3.20	3.00	2.70
3.6	7	6	4.10	4.10	4.00	3.70	3.40
5.6	7	6	6.50	6.40	6.30	5.80	5.30
7.1	7	6	8.20	8.10	8.00	7.40	6.80

### NOTE

- The performance table shows the average value of each conditions.

# 4. Dimensional Drawing

## WindFree™ 1Way Cassette

AM017DN1DKG/EU, AM022DN1DKG/EU

Units : mm [inches]

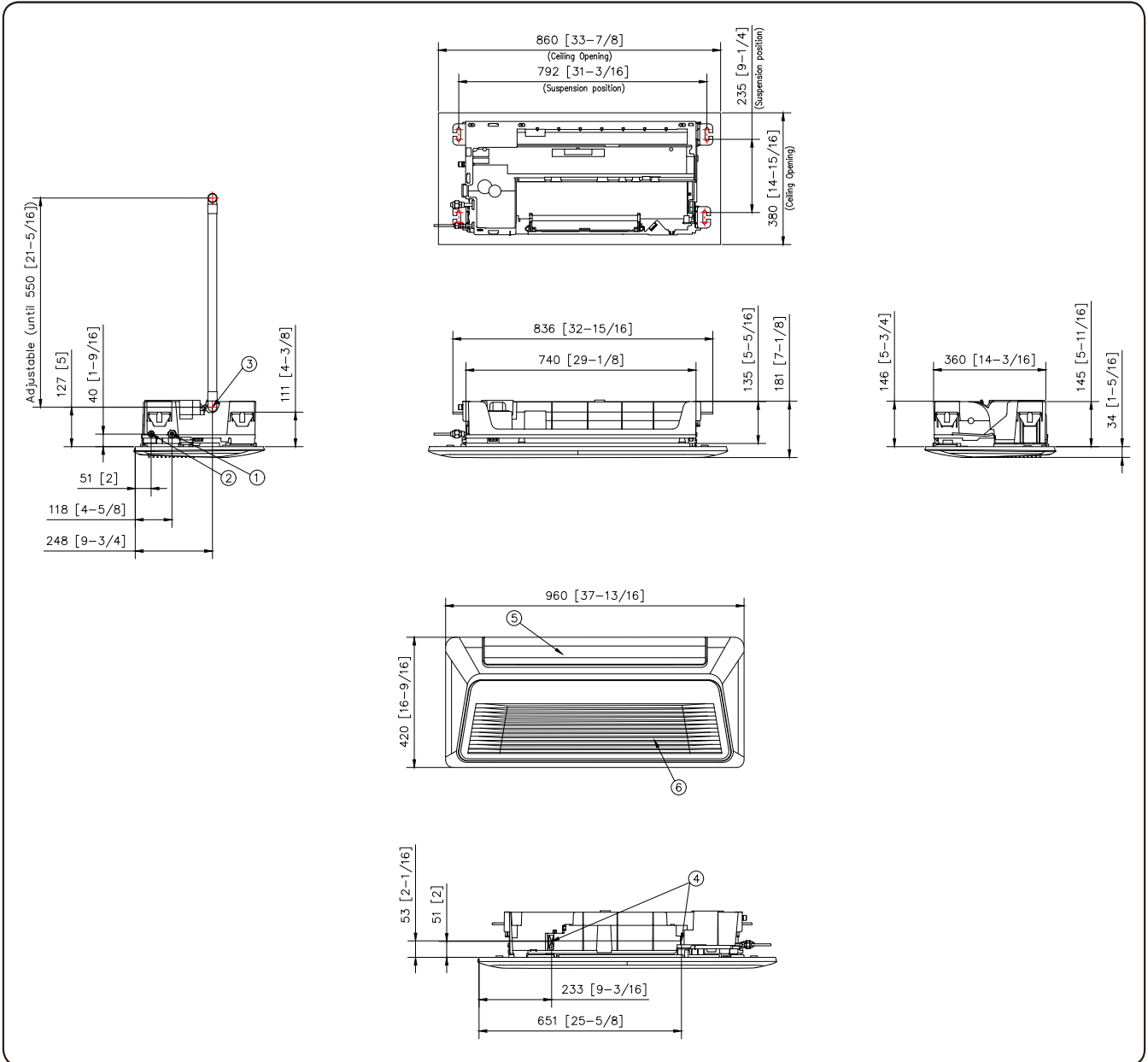

No.	Name	Description
1	Gas pipe connection	Φ 12.7 [1/2]
2	Liquid pipe connection	Φ 6.35 [1/4]
3	Drain pipe connection	VP-25(OD32, ID25)
4	Power supply & Communication wiring conduit	-
5	Air outlet louver	-
6	Air inlet grille	-

### NOTE

- As for suspension bolt, please use M8 ~ M10.  
(Procured at local site)

# 4. Dimensional Drawing

## WindFree™ 1Way Cassette

AM028DN1DKG/EU, AM036DN1DKG/EU

Units : mm [inches]

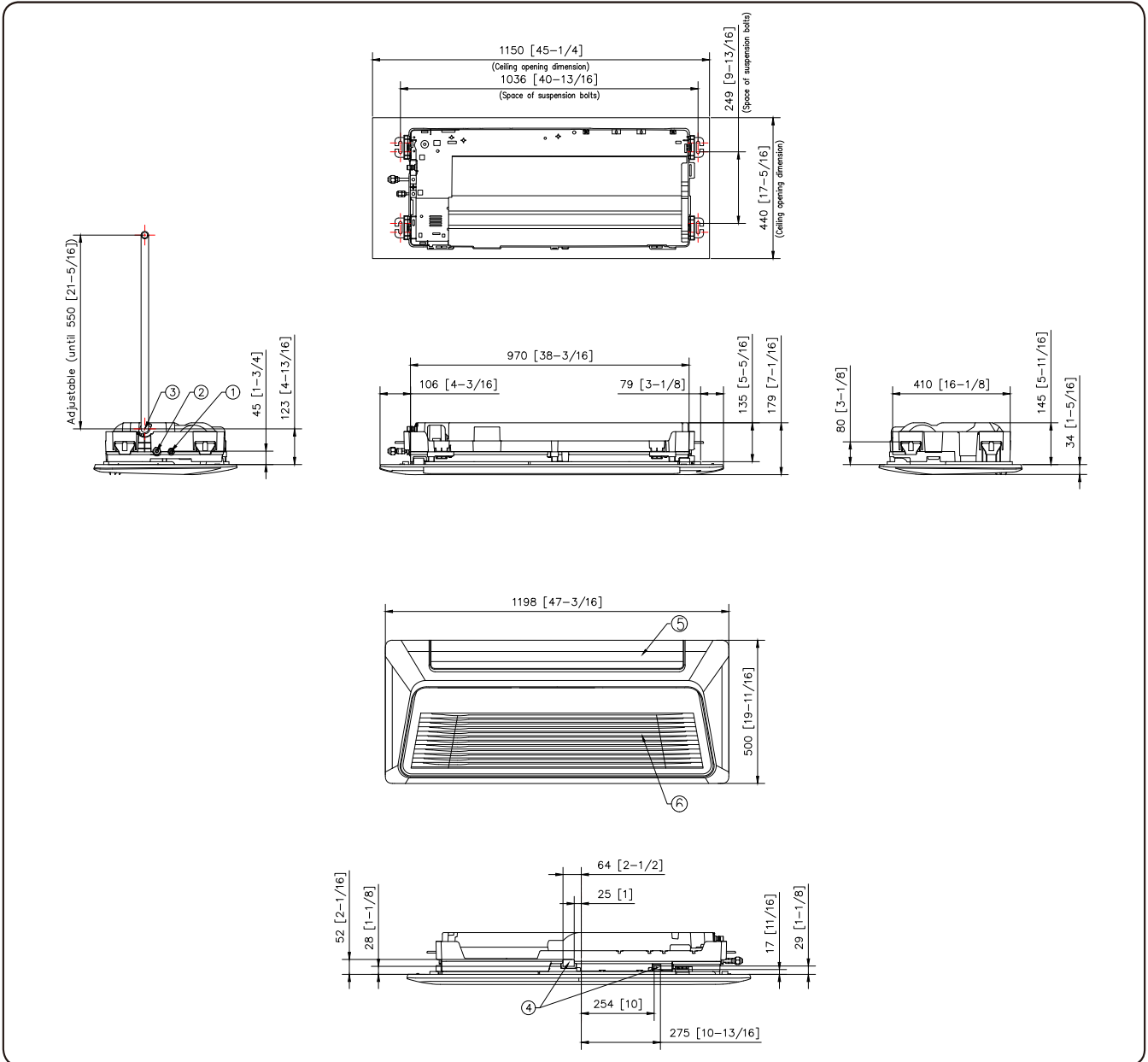

No.	Name	Description
1	Liquid pipe connection	∅ 6.35 [1/4]
2	Gas pipe connection	∅ 12.7 [1/2]
3	Drain pipe connection	VP-25(OD32, ID25)
4	Power supply & Communication wiring conduit	-
5	Air outlet louver	-
6	Air inlet grille	-

### NOTE

- As for suspension bolt, please use M8 ~ M10.  
(Procured at local site)

# 4. Dimensional Drawing

## WindFree™ 1Way Cassette

AM056DN1DKG/EU, AM071DN1DKG/EU

Units : mm [inches]

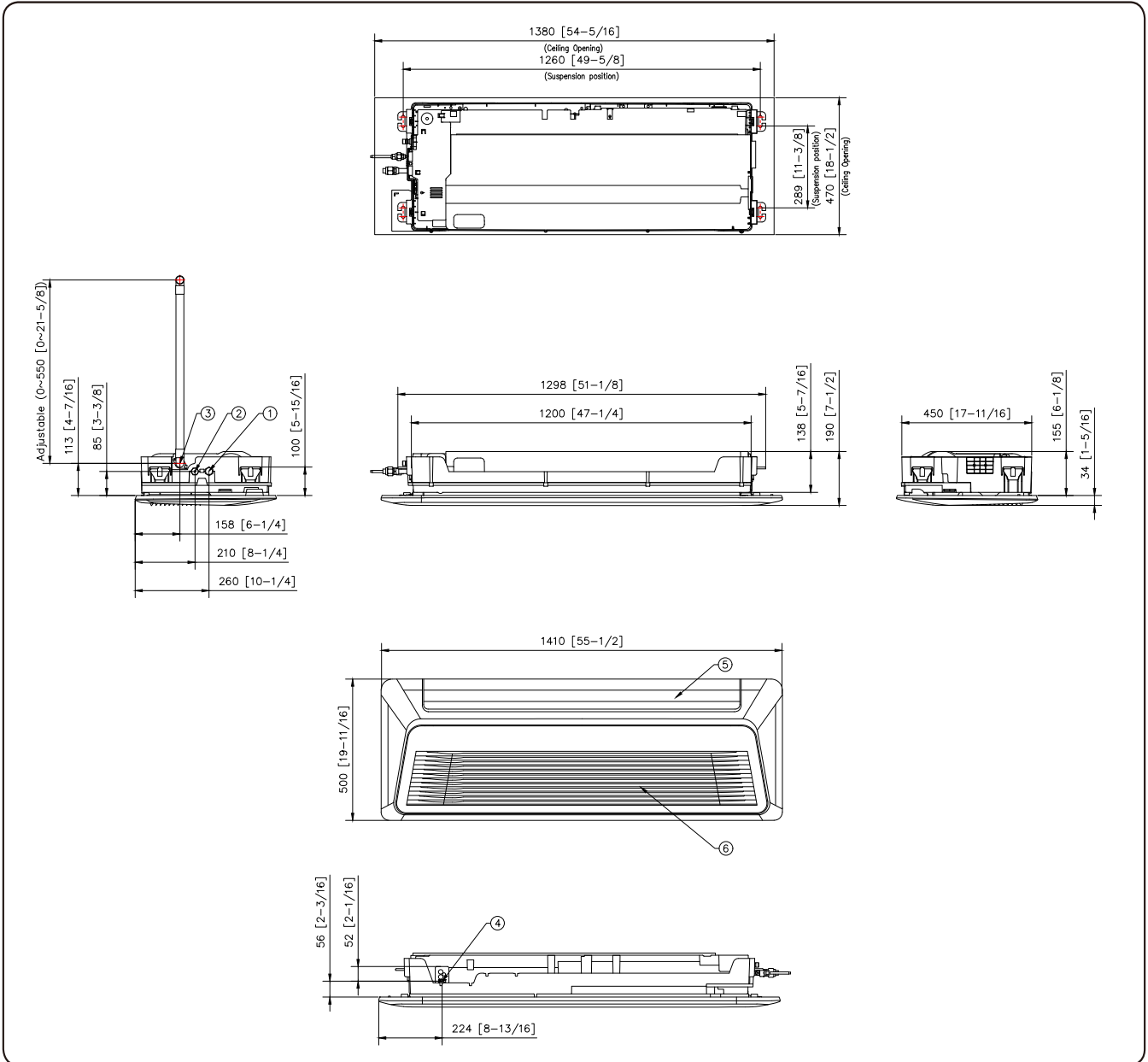

No.	Name	Description	
		AM056DN1DKG/EU	AM071DN1DKG/EU
1	Gas pipe connection	Φ 12.7 [1/2]	Φ 15.88 [5/8]
2	Liquid pipe connection	Φ 6.35 [1/4]	Φ 9.52 [3/8]
3	Drain pipe connection	VP-25(OD32, ID25)	
4	Power supply & Communication wiring conduit	-	
5	Air outlet louver	-	
6	Air inlet grille	-	

### NOTE

- As for suspension bolt, please use M8 ~ M10.  
(Procured at local site)

# 5. Center of Gravity

## WindFree™ 1Way Cassette

Units : mm [inches]

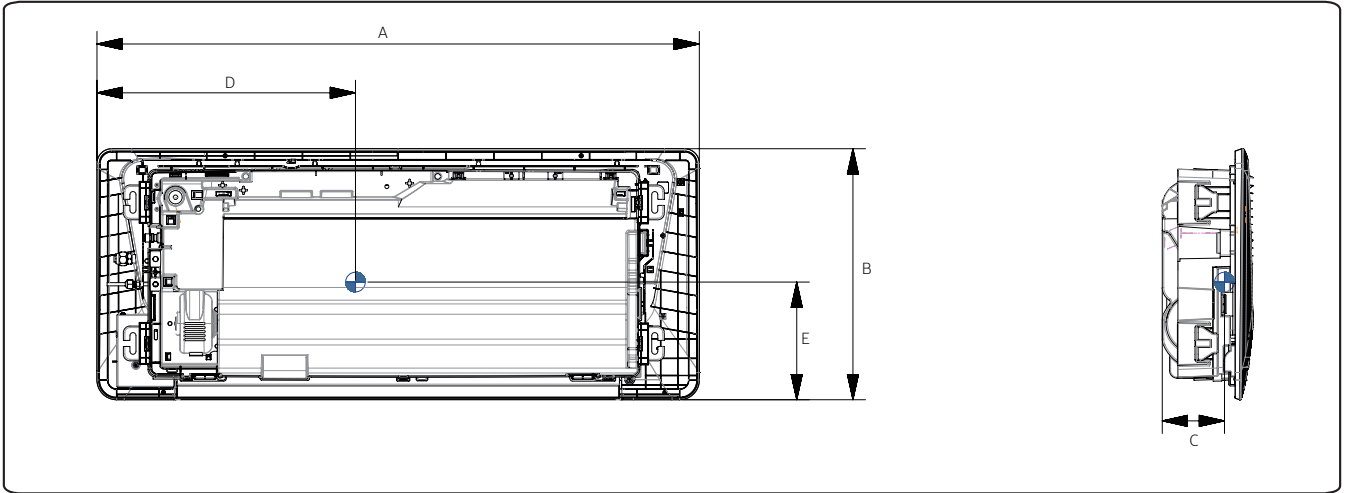

Model	A	B	C	D	E
AM017DN1DKG/EU AM022DN1DKG/EU	960 [37-13/16]	420 [16-9/16]	108 [4-1/4]	465 [18-5/16]	160 [6-5/16]
AM028DN1DKG/EU AM036DN1DKG/EU	1,198 [47-3/16]	500 [19-11/16]	108 [4-1/4]	555 [21-7/8]	200 [7-7/8]
AM056DN1DKG/EU AM071DN1DKG/EU	1,410 [55-1/2]	500 [19-11/16]	108 [4-1/4]	755 [29-3/4]	200 [7-7/8]

# 6. Electrical Wiring Diagram

## WindFree™ 1Way Cassette

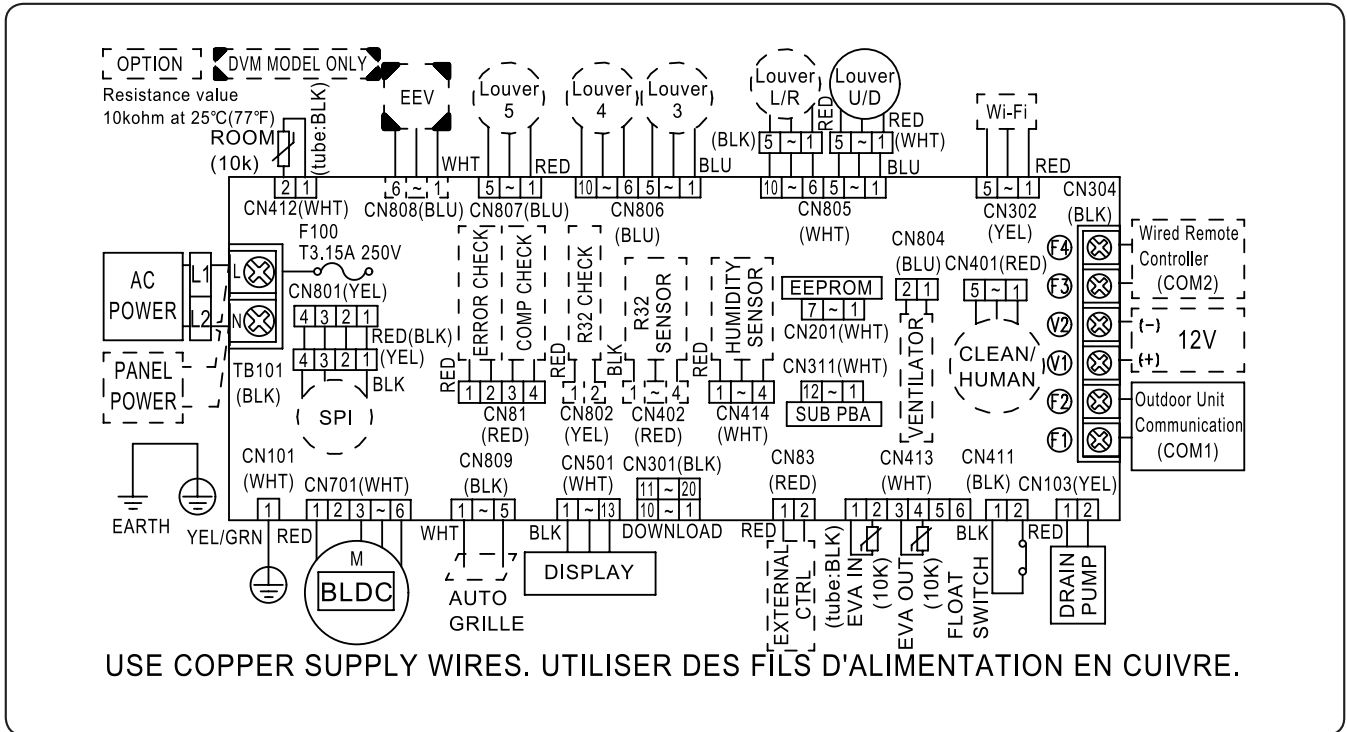

F100	FUSE	ROOM(10K)	Thermistor - Indoor Room
EEV	Electronic Expansion Valve	EVA-IN(10K)	Thermistor - IDU heat exchanger In
M-BLDC	Motor for Indoor Fan	EVA-OUT(10K)	Thermistor - IDU heat exchanger Out
		EXTERNAL CTRL	External Control

### NOTE

- This wiring diagram applies only to the indoor unit.
- Symbols show as follow :  
BLK: black, RED: red, BLU: blue, WHT: white, YEL: yellow, BRN: brown, SKY: sky blue, GRN: green
- For connection wiring indoor-outdoor transmission F1-F2, indoor-wired remote controller transmission F3-F4.
- Protective earth(SCREW)

# 7. Sound Data

## WindFree™ 1Way Cassette

### Sound Pressure level

Unit: dB(A)

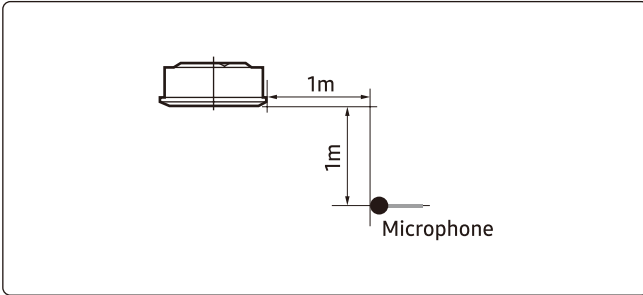

Model	High	Mid	Low	WindFree
AM017DN1DKG/EU	28	26	24	24
AM022DN1DKG/EU	29	26	24	24
AM028DN1DKG/EU	32	28	24	24
AM036DN1DKG/EU	37	33	30	30

• NR Curve

1) AM017DN1DKG/EU

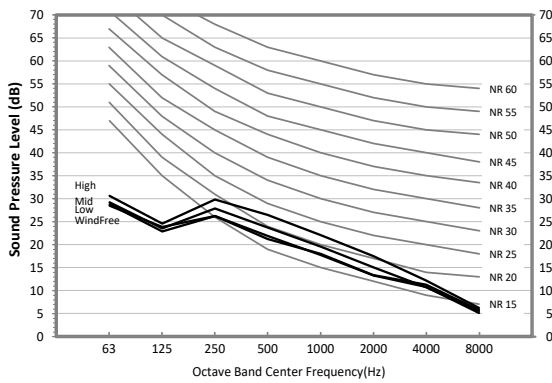

2) AM022DN1DKG/EU

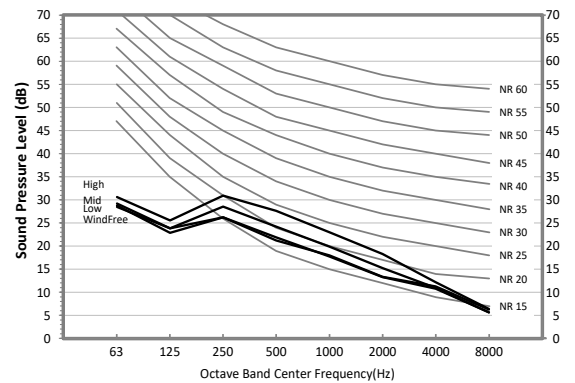

3) AM028DN1DKG/EU

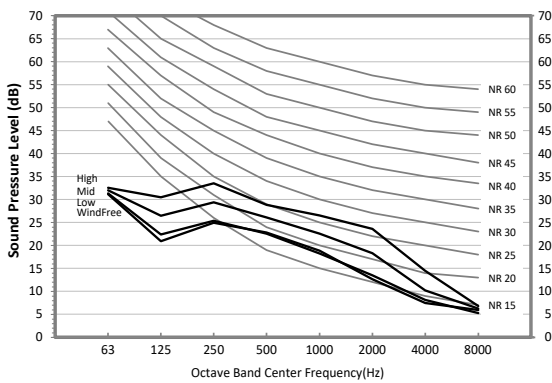

4) AM036DN1DKG/EU

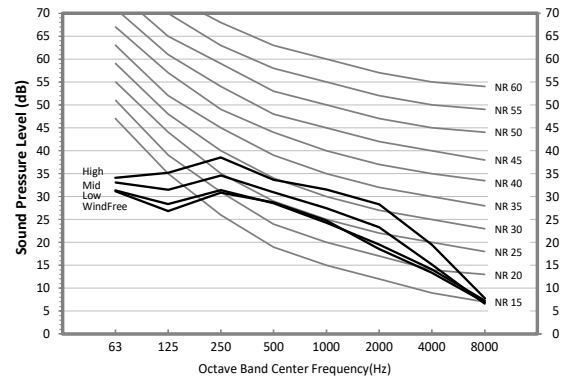

**NOTE**

- Specifications may be subject to change without prior notice.
  - Sound pressure level is obtained in an anechoic room.
  - Sound pressure level is a relative value, depending on the distance and acoustic environment.
  - Sound pressure level may differ depending on operation condition.
  - dBA = A weighted sound pressure level
  - Reference acoustic pressure 0 dB = 20μPa

# 7. Sound Data

## WindFree™ 1Way Cassette

### Sound Pressure level

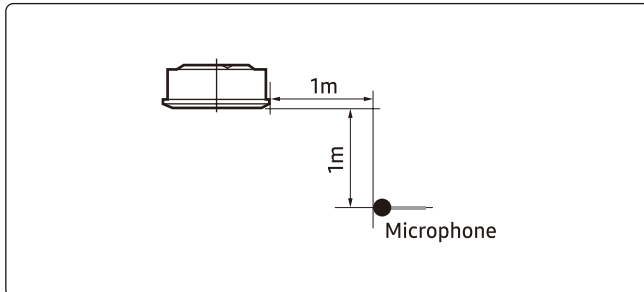

Unit: dB(A)

Model	High	Mid	Low	WindFree
AM056DN1DKG/EU	41	38	35	30
AM071DN1DKG/EU	42	39	36	31

#### • NR Curve

1) AM056DN1DKG/EU

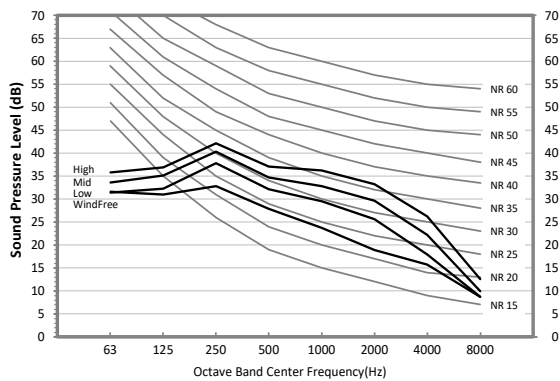

2) AM071DN1DKG/EU

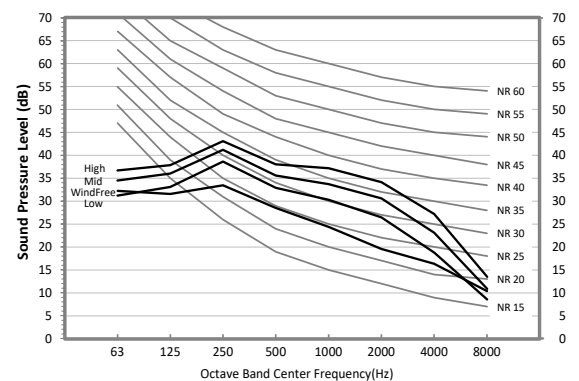

#### NOTE

- Specifications may be subject to change without prior notice.
  - Sound pressure level is obtained in an anechoic room.
  - Sound pressure level is a relative value, depending on the distance and acoustic environment.
  - Sound pressure level may differ depending on operation condition.
  - dBA = A weighted sound pressure level
  - Reference acoustic pressure 0 dB = 20μPa

# 7. Sound Data

## WindFree™ 1Way Cassette

### Sound Power level

Unit: dB(A)

#### NOTE

- Specifications may be subject to change without prior notice
  - Sound power level is an absolute value that a sound source generates.
  - dB(A) = A-weighted sound power level.
  - Reference power : 1pW.
  - Measured according to ISO 3741.

Model	High
AM017DN1DKG/EU	46
AM022DN1DKG/EU	47
AM028DN1DKG/EU	50
AM036DN1DKG/EU	55

#### NR Curve

1) AM017DN1DKG/EU

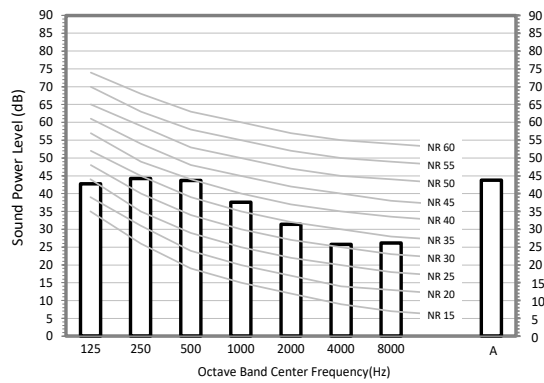

2) AM022DN1DKG/EU

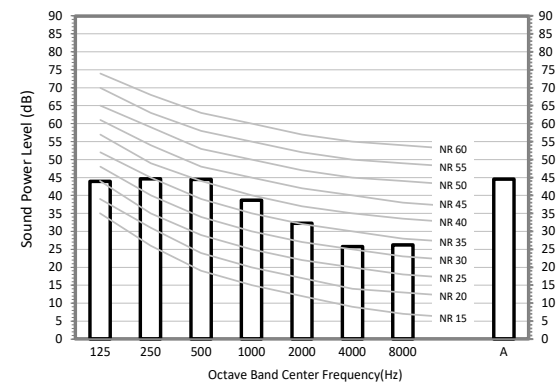

3) AM028DN1DKG/EU

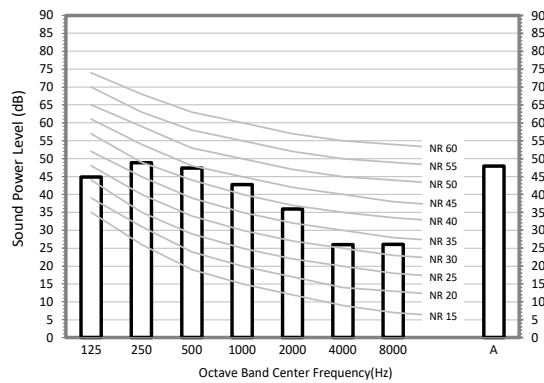

4) AM036DN1DKG/EU

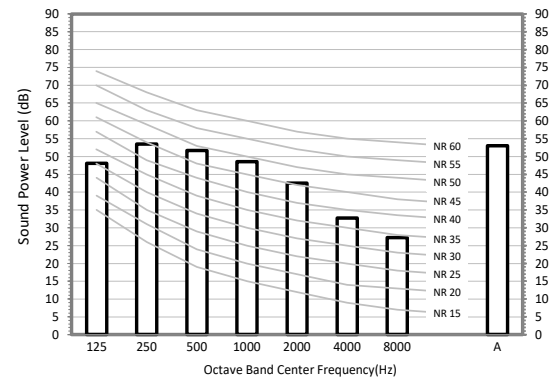

# 7. Sound Data

## WindFree™ 1Way Cassette

### Sound Power level

Unit: dB(A)

#### NOTE

- Specifications may be subject to change without prior notice
  - Sound power level is an absolute value that a sound source generates.
  - dB(A) = A-weighted sound power level.
  - Reference power : 1pW.
  - Measured according to ISO 3741.

Model	High
AM056DN1DKG/EU	59
AM071DN1DKG/EU	60

- NR Curve

5) AM056DN1DKG/EU

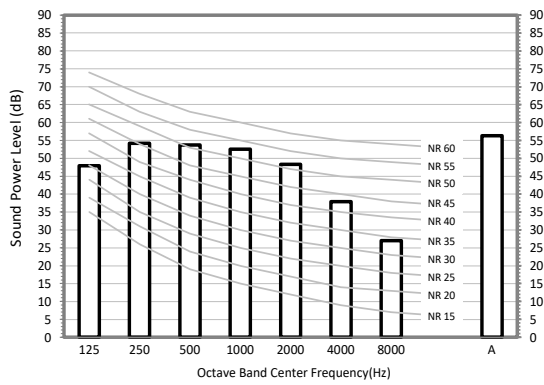

6) AM071DN1DKG/EU

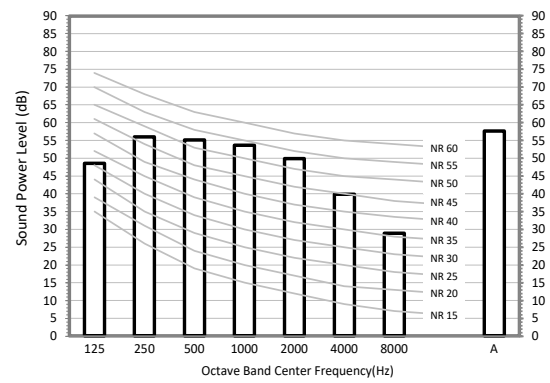

# 8. Temperature and air flow distribution

## WindFree™ 1Way Cassette

- AM017DN1DKG/EU

Cooling Air Velocity distribution Discharge angle : 60°

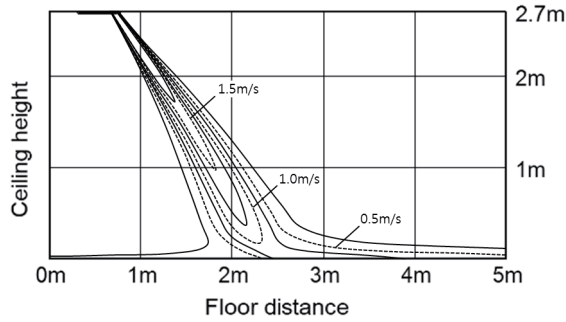

Cooling temperature distribution Discharge angle : 60°

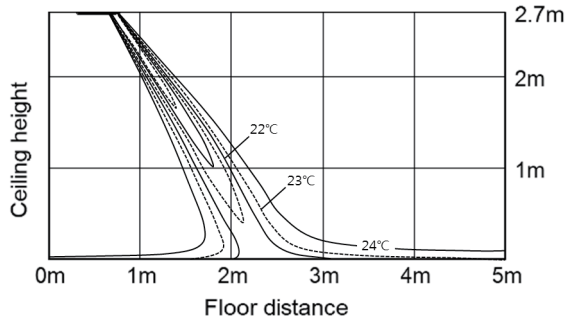

Heating Air Velocity distribution Discharge angle : 60°

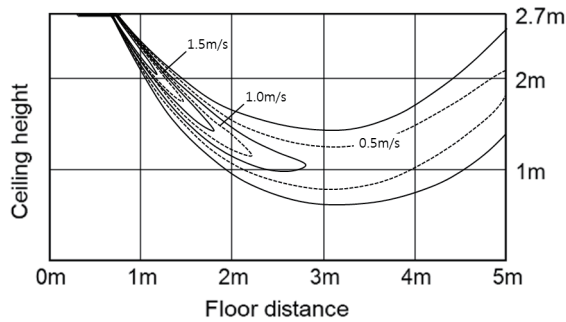

Heating temperature distribution Discharge angle : 60°

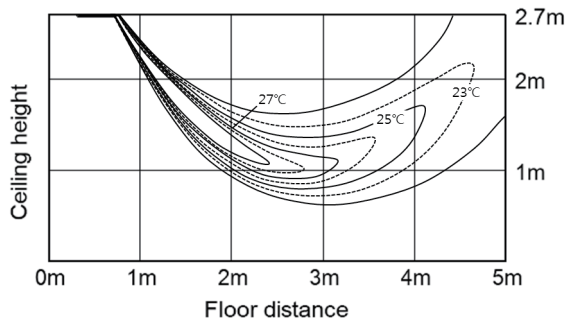

# 8. Temperature and air flow distribution

## WindFree™ 1Way Cassette

- AM022DN1DKG/EU

Cooling Air Velocity distribution Discharge angle : 60°

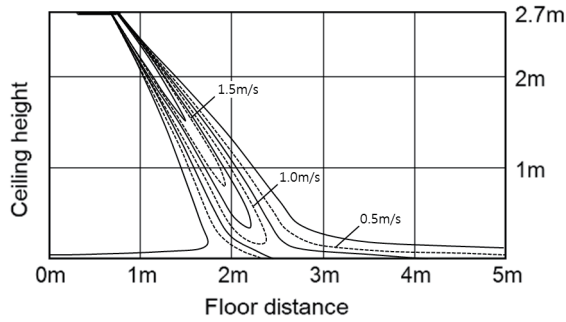

Cooling temperature distribution Discharge angle : 60°

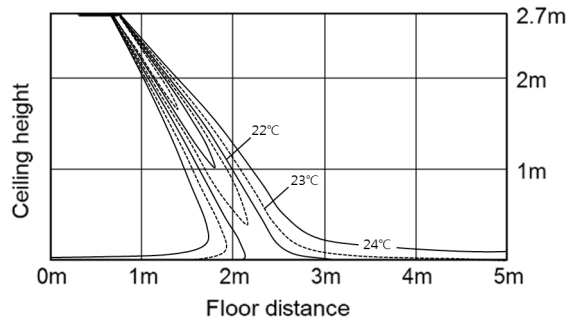

Heating Air Velocity distribution Discharge angle : 60°

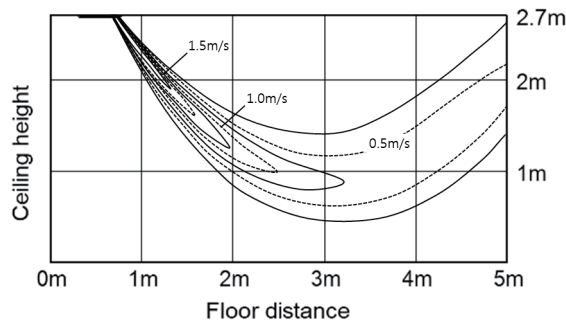

Heating temperature distribution Discharge angle : 60°

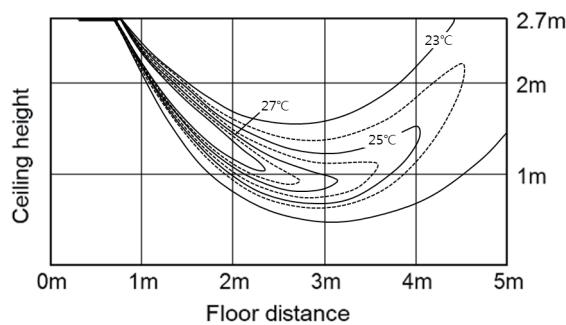

# 8. Temperature and air flow distribution

## WindFree™ 1Way Cassette

- AM028DN1DKG/EU

Cooling Air Velocity distribution      Discharge angle : 60°

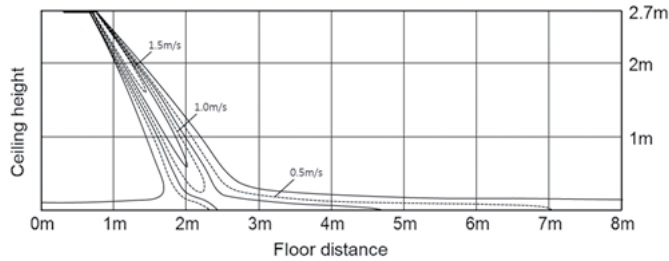

Cooling temperature distribution      Discharge angle : 60°

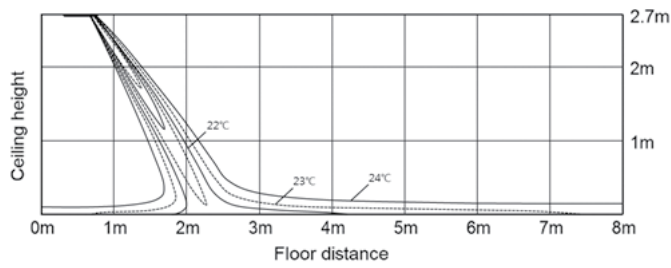

Heating Air Velocity distribution      Discharge angle : 60°

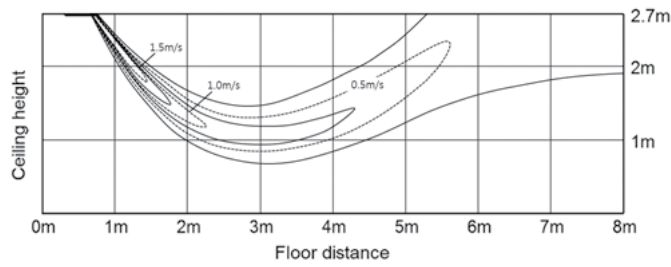

Heating temperature distribution      Discharge angle : 60°

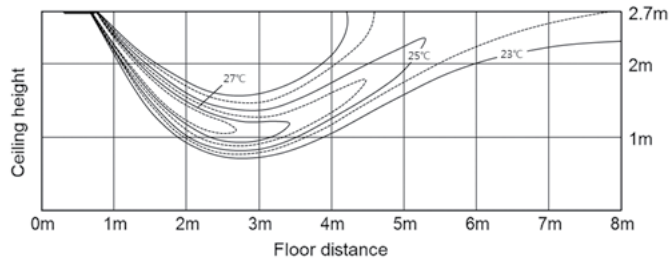

# 8. Temperature and air flow distribution

## WindFree™ 1Way Cassette

- AM036DN1DKG/EU

Cooling Air Velocity distribution      Discharge angle : 60°

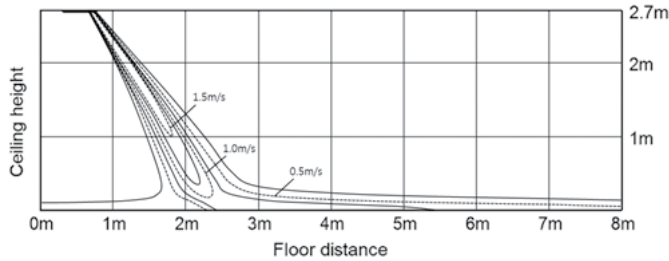

Cooling temperature distribution      Discharge angle : 60°

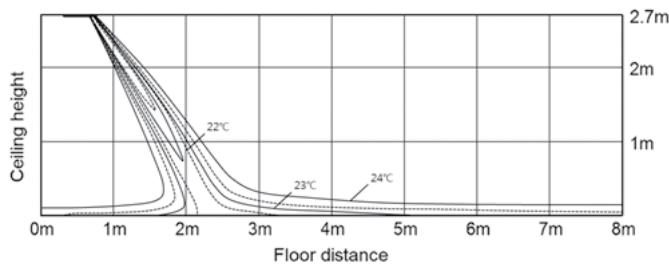

Heating Air Velocity distribution      Discharge angle : 60°

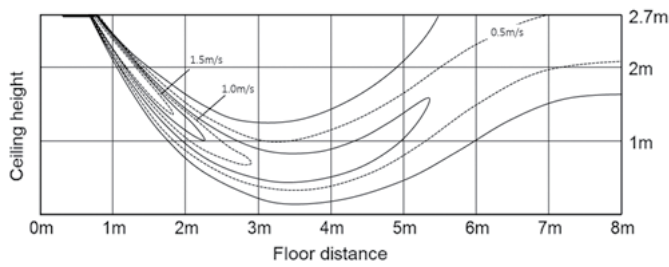

Heating temperature distribution      Discharge angle : 60°

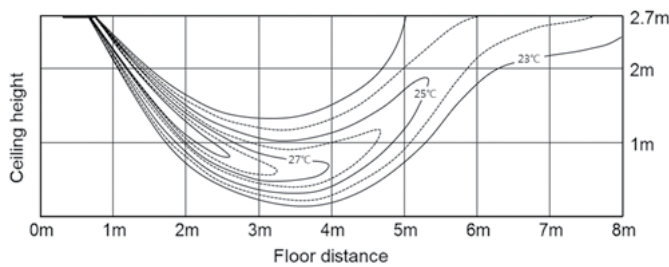

# 8. Temperature and air flow distribution

## WindFree™ 1Way Cassette

- AM056DN1DKG/EU

Cooling Air Velocity distribution      Discharge angle : 60°

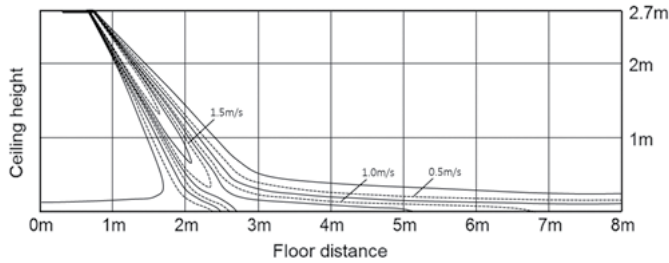

Cooling temperature distribution      Discharge angle : 60°

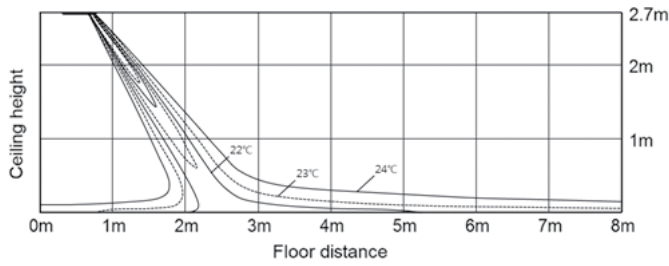

Heating Air Velocity distribution      Discharge angle : 60°

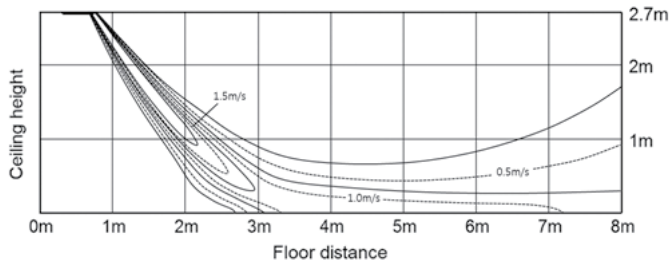

Heating temperature distribution      Discharge angle : 60°

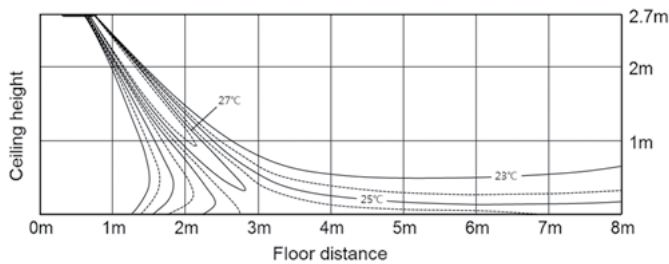

# 8. Temperature and air flow distribution

## WindFree™ 1Way Cassette

- AM071DN1DKG/EU

Cooling Air Velocity distribution      Discharge angle : 60°

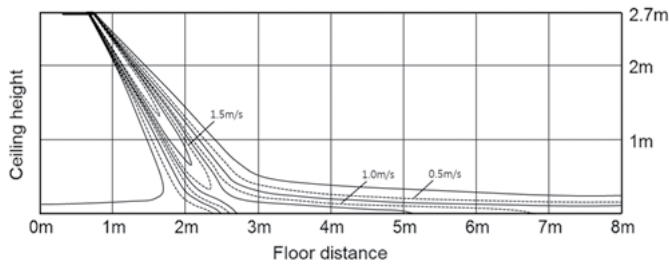

Cooling temperature distribution      Discharge angle : 60°

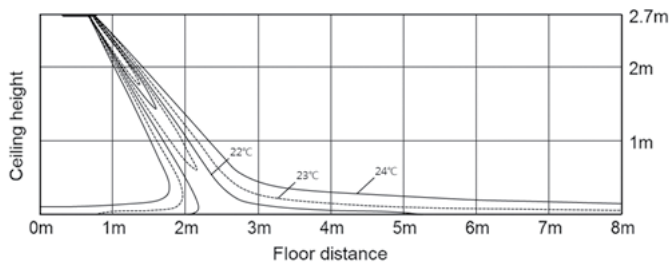

Heating Air Velocity distribution      Discharge angle : 60°

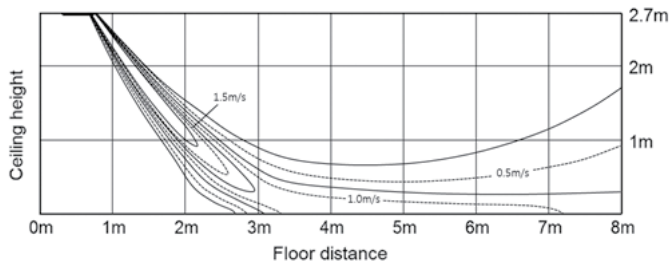

Heating temperature distribution      Discharge angle : 60°

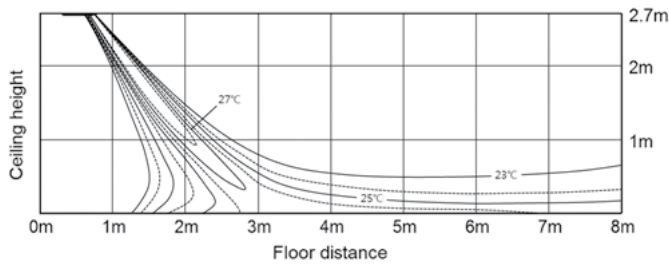

# 9. Piping Diagram

## WindFree™ 1Way Cassette

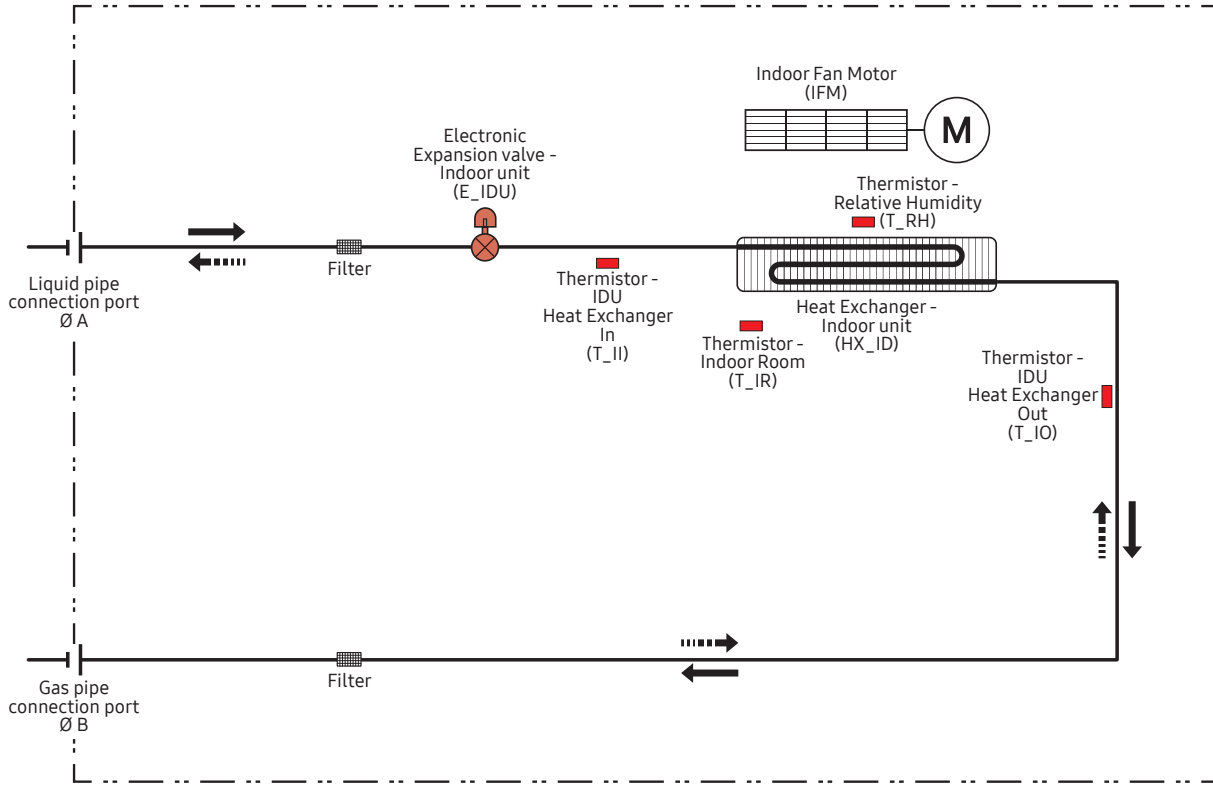

Refrigerant flow	
Cooling	Heating

# WindFree™ 4Way Cassette (600x600)

---

1. Specification	31
2. Summary Table	35
3. Capacity Table	36
4. Dimensional Drawing	37
5. Center of Gravity	38
6. Electrical Wiring Diagram	39
7. Sound Data	40
8. Temperature and air flow distribution	44
9. Piping Diagram	48

---

# Line-up

## WindFree™ 4Way Cassette (600x600)

Capacity (kW)						
1.5	2.2	2.8	3.6	4.5	5.6	6.0



# 1. Specification

## WindFree™ 4Way Cassette (600x600)

Model Name				AM015DNNDKG/EU	AM022DNNDKG/EU	AM028DNNDKG/EU	AM036DNNDKG/EU
Power Supply		Φ, #, V, Hz		1,2,220-240,50/60	1,2,220-240,50/60	1,2,220-240,50/60	1,2,220-240,50/60
Performance	Capacity	Cooling	kW	1.50	2.20	2.80	3.60
			Btu/h	5,100	7,500	9,600	12,300
		Heating	kW	1.70	2.50	3.20	4.00
			Btu/h	5,800	8,500	10,900	13,600
Power	Power Input	Cooling	W	18.00	18.00	18.00	20.00
		Heating		18.00	18.00	18.00	20.00
	Current Input	Cooling	A	0.17	0.17	0.17	0.19
		Heating		0.17	0.17	0.17	0.19
	Current	MCA	A	0.23	0.23	0.23	0.25
		MFA		15	15	15	15
Heat exchanger	Type		-	Fin & Tube	Fin & Tube	Fin & Tube	Fin & Tube
	Material	Fin	-	Al	Al	Al	Al
		Tube	-	Cu	Cu	Cu	Cu
	Fin Treatment		-	Green Hydrophile	Green Hydrophile	Green Hydrophile	Green Hydrophile
Fan	Type	Type	-	Turbo Fan	Turbo Fan	Turbo Fan	Turbo Fan
	Quantity		ea	1	1	1	1
	Air Flow Rate	H/M/L	CMM	8.5/7.2/6.5	9.0/7.7/6.5	10.0/8.5/7.5	10.5/9.0/7.5
			l/s	142/120/108	150/128/108	167/142/125	175/150/125
Fan Motor	Model		-	BLDC Motor	BLDC Motor	BLDC Motor	BLDC Motor
	Output x n		W	65 x 1	65 x 1	65 x 1	65 x 1
Piping Connections	Liquid Pipe		Type	Flare connection	Flare connection	Flare connection	Flare connection
			Φ,mm	6.35	6.35	6.35	6.35
			Φ, inch	1/4	1/4	1/4	1/4
	Gas Pipe		Type	Flare connection	Flare connection	Flare connection	Flare connection
			Φ,mm	12.7	12.7	12.7	12.7
			Φ, inch	1/2	1/2	1/2	1/2
	Heat insulation		-	Both liquid & gas pipes	Both liquid & gas pipes	Both liquid & gas pipes	Both liquid & gas pipes
	Drain Pipe		Φ,mm	VP25 (OD 32,ID 25)	VP25 (OD 32,ID 25)	VP25 (OD 32,ID 25)	VP25 (OD 32,ID 25)

# 1. Specification

## WindFree™ 4Way Cassette (600x600)

Model Name				AM015DNNDKG/EU	AM022DNNDKG/EU	AM028DNNDKG/EU	AM036DNNDKG/EU
Wiring connections	Communication	Min.	mm <sup>2</sup>	0.75	0.75	0.75	0.75
		Remark	-	F1, F2	F1, F2	F1, F2	F1, F2
Refrigerant	Type		-	R32	R32	R32	R32
	Electronic Expansion Valve		-	EEV INCLUDED	EEV INCLUDED	EEV INCLUDED	EEV INCLUDED
Sound	Sound Pressure	H/M/L/W	dB(A)	30/28/23/23	32/29/25/25	33/30/26/26	34/30/26/26
	Sound Power	Cooling		46	47	50	51
Dimensions	Net Weight		kg	11.5	11.6	11.6	11.6
	Shipping Weight		kg	13.6	13.8	13.8	13.8
	Net Dimensions (W×H×D)		mm	575 x 250 x 575	575 x 250 x 575	575 x 250 x 575	575 x 250 x 575
	Shipping Dimensions (W×H×D)		mm	623 x 298 x 653	623 x 298 x 653	623 x 298 x 653	623 x 298 x 653
Panel	Model Name		-	PC4SUFMANW	PC4SUFMANW	PC4SUFMANW	PC4SUFMANW
	Type		-	Wind-Free Type	Wind-Free Type	Wind-Free Type	Wind-Free Type
	Material		-	HIPS	HIPS	HIPS	HIPS
	Color		-	White	White	White	White
	Net Weight		kg	2.7	2.7	2.7	2.7
	Shipping Weight		kg	3.9	3.9	3.9	3.9
	Net Dimensions (W×H×D)		mm	620 x 34 x 620	620 x 34 x 620	620 x 34 x 620	620 x 34 x 620
	Shipping Dimensions (W×H×D)		mm	670 x 120 x 655	670 x 120 x 655	670 x 120 x 655	670 x 120 x 655
Drain Pump	Drain Pump		-	INCLUDED	INCLUDED	INCLUDED	INCLUDED
	Max. lifting Height / Displacement		mm / Liter/h	750 / 24	750 / 24	750 / 24	750 / 24

### NOTE

- Specification may be subject to change without prior notice.
- 1) Capacities are based on (Equivalent refrigerant piping 7.5m, Level differences 0m);
  - Cooling : Indoor temperature 27°C DB, 19°C WB / Outdoor temperature 35°C DB, 24°C WB
  - Heating : Indoor temperature 20°C DB, 15°C WB / Outdoor temperature 7°C DB, 6°C WB
- 2) Sound level was acquired in an anechoic room. Thus actual noise level may be different depending on the installation conditions.
- 3) These products contain R32 (GWP=675) which is fluorinated greenhouse gas.
- 4) Select wire size based on the value of MCA

# 1. Specification

## WindFree™ 4Way Cassette (600x600)

Model Name				AM045DNNDKG/EU	AM056DNNDKG/EU	AM060DNNDKG/EU
Power Supply			Φ, #, V, Hz	1,2,220-240,50/60	1,2,220-240,50/60	1,2,220-240,50/60
Performance	Capacity	Cooling	kW	4.50	5.60	6.00
			Btu/h	15,400	19,100	20,500
		Heating	kW	5.00	6.30	6.80
			Btu/h	17,100	21,500	23,200
Power	Power Input	Cooling	W	23.00	28.00	31.00
		Heating		23.00	28.00	31.00
	Current Input	Cooling	A	0.22	0.27	0.30
		Heating		0.22	0.27	0.30
	Current	MCA	A	0.29	0.35	0.39
		MFA		15	15	15
Heat exchanger	Type		-	Fin & Tube	Fin & Tube	Fin & Tube
	Material	Fin	-	Al	Al	Al
		Tube	-	Cu	Cu	Cu
	Fin Treatment		-	Green Hydrophile	Green Hydrophile	Green Hydrophile
Fan	Type	Type	-	Turbo Fan	Turbo Fan	Turbo Fan
	Quantity		ea	1	1	1
	Air Flow Rate	H/M/L	CMM	11.5/10.2/9.0	13.0/11.0/9.5	13.5/12.0/10.2
			l/s	192/170/150	217/183/158	225/200/170
Fan Motor	Model		-	BLDC Motor	BLDC Motor	BLDC Motor
	Output x n		W	65 x 1	65 x 1	65 x 1
Piping Connections	Liquid Pipe		Type	Flare connection	Flare connection	Flare connection
			Φ,mm	6.35	6.35	6.35
			Φ, inch	1/4	1/4	1/4
	Gas Pipe		Type	Flare connection	Flare connection	Flare connection
			Φ,mm	12.7	12.7	12.7
			Φ, inch	1/2	1/2	1/2
	Heat insulation		-	Both liquid & gas pipes	Both liquid & gas pipes	Both liquid & gas pipes
	Drain Pipe		Φ,mm	VP25 (OD 32,ID 25)	VP25 (OD 32,ID 25)	VP25 (OD 32,ID 25)

# 1. Specification

## WindFree™ 4Way Cassette (600x600)

Model Name				AM045DNNDKG/EU	AM056DNNDKG/EU	AM060DNNDKG/EU
Wiring connections	Communication	Min.	mm <sup>2</sup>	0.75	0.75	0.75
		Remark	-	F1, F2	F1, F2	F1, F2
Refrigerant	Type		-	R32	R32	R32
	Electronic Expansion Valve		-	EEV INCLUDED	EEV INCLUDED	EEV INCLUDED
Sound	Sound Pressure	H/M/L/W	dB(A)	36/34/32/32	39/36/33/33	40/38/35/35
	Sound Power	Cooling		53	56	57
Dimensions	Net Weight		kg	12	12	12
	Shipping Weight		kg	14	14	14
	Net Dimensions (W×H×D)		mm	575 x 250 x 575	575 x 250 x 575	575 x 250 x 575
	Shipping Dimensions (W×H×D)		mm	623 x 298 x 653	623 x 298 x 653	623 x 298 x 653
Panel	Model Name		-	PC4SUFMANW	PC4SUFMANW	PC4SUFMANW
	Type		-	Wind-Free Type	Wind-Free Type	Wind-Free Type
	Material		-	HIPS	HIPS	HIPS
	Color		-	White	White	White
	Net Weight		kg	2.7	2.7	2.7
	Shipping Weight		kg	3.9	3.9	3.9
	Net Dimensions (W×H×D)		mm	620 x 34 x 620	620 x 34 x 620	620 x 34 x 620
	Shipping Dimensions (W×H×D)		mm	670 x 120 x 655	670 x 120 x 655	670 x 120 x 655
Drain Pump	Drain Pump		-	INCLUDED	INCLUDED	INCLUDED
	Max. lifting Height / Displacement		mm / Liter/h	750 / 24	750 / 24	750 / 24

### NOTE

- Specification may be subject to change without prior notice.
- 1) Capacities are based on (Equivalent refrigerant piping 7.5m, Level differences 0m);
    - Cooling : Indoor temperature 27°C DB, 19°C WB / Outdoor temperature 35°C DB, 24°C WB
    - Heating : Indoor temperature 20°C DB, 15°C WB / Outdoor temperature 7°C DB, 6°C WB
  - 2) Sound level was acquired in an anechoic room. Thus actual noise level may be different depending on the installation conditions.
  - 3) These products contain R32 (GWP=675) which is fluorinated greenhouse gas.
  - 4) Select wire size based on the value of MCA

## 2. Summary Table

### WindFree™ 4Way Cassette (600x600)

#### Performance Characteristics

Model Code	Net Weight (kg)	Fan Speed	Nominal Capacity (kW)			Airflow (CMM)	Sound Pressure (dBA)	Sound Power (dBA)
			Cooling	Sensible	Heating			
AM015DNNDKG/EU	11.5	High	1.5	1.0	1.7	8.5	30	46
		Mid	1.3	0.9	1.6	7.2	28	-
		Low	1.2	0.8	1.5	6.5	23	-
		W/Free	0.8	0.6	-	3.5	23	-
AM022DNNDKG/EU	11.6	High	2.2	1.5	2.5	9.0	32	47
		Mid	1.9	1.3	2.3	7.7	29	-
		Low	1.6	1.1	2.1	6.5	25	-
		W/Free	1.1	0.8	-	3.6	25	-
AM028DNNDKG/EU	11.6	High	2.8	2.0	3.2	10.0	33	50
		Mid	2.4	1.7	3.0	8.5	30	-
		Low	2.2	1.6	2.8	7.5	26	-
		W/Free	1.3	1.0	-	3.8	26	-
AM036DNNDKG/EU	11.6	High	3.6	2.5	4.0	10.5	34	51
		Mid	3.1	2.2	3.7	9.0	30	-
		Low	2.7	1.9	3.4	7.5	26	-
		W/Free	1.7	1.2	-	4.4	26	-
AM045DNNDKG/EU	12.0	High	4.5	3.1	5.0	11.5	36	53
		Mid	4.1	2.8	4.7	10.2	34	-
		Low	3.6	2.5	4.4	9.0	32	-
		W/Free	2.2	1.6	-	4.6	32	-
AM056DNNDKG/EU	12.0	High	5.6	4.2	6.3	13.0	39	56
		Mid	4.8	3.6	5.8	11.0	36	-
		Low	4.2	3.2	5.4	9.5	33	-
		W/Free	2.6	1.9	-	4.8	33	-
AM060DNNDKG/EU	12.0	High	6.0	4.5	6.8	13.5	40	57
		Mid	5.4	4.1	6.4	12.0	38	-
		Low	4.7	3.5	5.9	10.2	35	-
		W/Free	2.8	2.1	-	5.0	35	-

#### NOTE

- Sound data is based on cooling operation.

#### Electrical Characteristics

Indoor Unit	Power Supply (Ø, #, V, Hz)	Power Input (W)	Current Input (A)	MCA (A)	MFA (A)	FLA (A)
AM015DNNDKG/EU	1,2,220-240,50/60	18.0	0.17	0.23	15	0.18
AM022DNNDKG/EU	1,2,220-240,50/60	18.0	0.17	0.23	15	0.18
AM028DNNDKG/EU	1,2,220-240,50/60	18.0	0.17	0.23	15	0.18
AM036DNNDKG/EU	1,2,220-240,50/60	20.0	0.19	0.25	15	0.20
AM045DNNDKG/EU	1,2,220-240,50/60	23.0	0.22	0.29	15	0.23
AM056DNNDKG/EU	1,2,220-240,50/60	28.0	0.27	0.35	15	0.28
AM060DNNDKG/EU	1,2,220-240,50/60	31.0	0.30	0.39	15	0.31

#### NOTE

- MCA: Minimum circuit amperes
- MFA: Maximum fuse amperes
- FLA: Full load amperes
- Select wire size based on the value of MCA

# 3. Capacity Table

## WindFree™ 4Way Cassette (600x600)

### Cooling

TC : Total Capacity, SHC : Sensible Heat Capacity

Model	Outdoor temperature (°C, DB)	Indoor temperature (°C, WB)													
		14.0		16.0		18.0		19.0		20.0		22.0		24.0	
		TC	SHC	TC	SHC	TC	SHC	TC	SHC	TC	SHC	TC	SHC	TC	SHC
		kW	kW	kW	kW	kW	kW	kW	kW	kW	kW	kW	kW	kW	kW
1.50	35	1.00	0.90	1.20	1.00	1.40	1.10	1.50	1.00	1.60	1.00	1.70	1.00	1.80	1.00
2.20	35	1.50	1.30	1.80	1.40	2.10	1.50	2.20	1.50	2.30	1.50	2.40	1.50	2.60	1.40
2.80	35	1.90	1.70	2.30	1.80	2.60	2.00	2.80	2.00	2.90	2.00	3.10	2.00	3.30	1.80
3.60	35	2.50	2.10	2.90	2.20	3.40	2.40	3.60	2.50	3.70	2.50	4.00	2.50	4.20	2.30
4.50	35	3.10	2.70	3.70	2.80	4.20	3.00	4.50	3.10	4.70	3.10	5.00	3.10	5.30	2.80
5.60	35	3.90	3.30	4.60	3.80	5.30	4.10	5.60	4.20	5.80	4.20	6.20	4.20	6.60	4.00
6.00	35	4.10	3.50	4.90	4.00	5.60	4.50	6.00	4.50	6.20	4.50	6.60	4.50	7.10	4.30

### Heating

TC : Total Capacity (kW)

Model	Outdoor temperature (°C)		Indoor temperature (°C, DB)				
			16.0	18.0	20.0	22.0	24.0
	DB	WB	TC	TC	TC	TC	TC
1.50	7	6	1.70	1.70	1.70	1.60	1.40
2.20	7	6	2.80	2.70	2.50	2.30	2.20
2.80	7	6	3.30	3.20	3.20	3.00	2.70
3.60	7	6	4.10	4.10	4.00	3.70	3.40
4.50	7	6	5.10	5.10	5.00	4.60	4.20
5.60	7	6	6.50	6.40	6.30	5.80	5.30
6.00	7	6	7.20	7.10	6.80	6.50	5.90

### NOTE

- The performance table shows the average value of each conditions.

# 4. Dimensional Drawing

## WindFree™ 4Way Cassette (600x600)

Units : mm [inches]

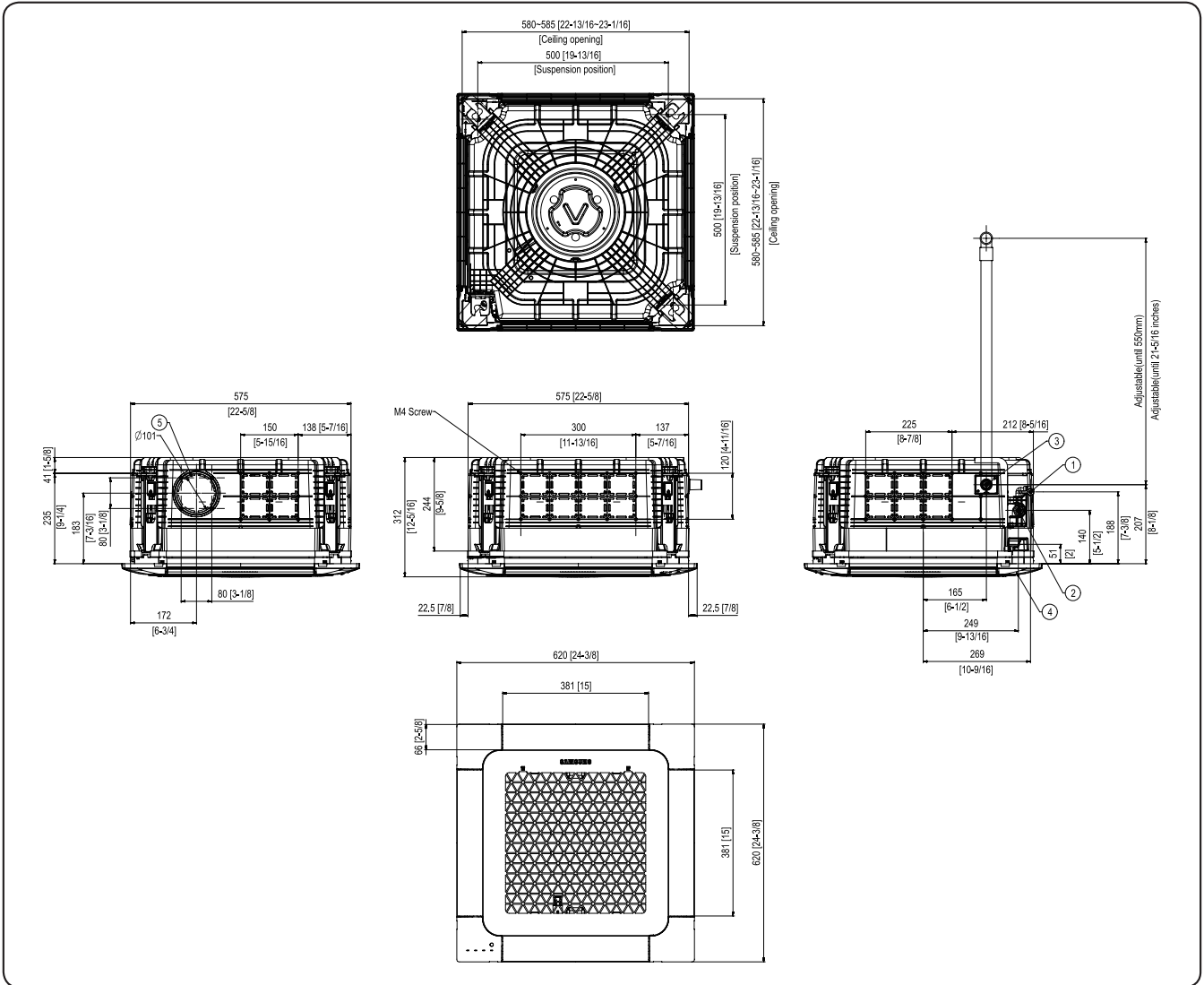

No.	Name	Description
1	Liquid pipe connection	Φ6.35(1/4)
2	Gas pipe connection	Φ12.7(1/2)
3	Drain pipe connection	VP-25(OD32, ID25)
4	Power supply & Communication wiring conduit	Use M4 Screw
5	Fresh air intake knockout hole	Φ10[4] , Use M4 Screw

### NOTE

- As for suspension bolt, please use M8 ~ M10. (Procured at local site)

# 5. Center of Gravity

## WindFree™ 4Way Cassette (600x600)

Units : mm [inches]

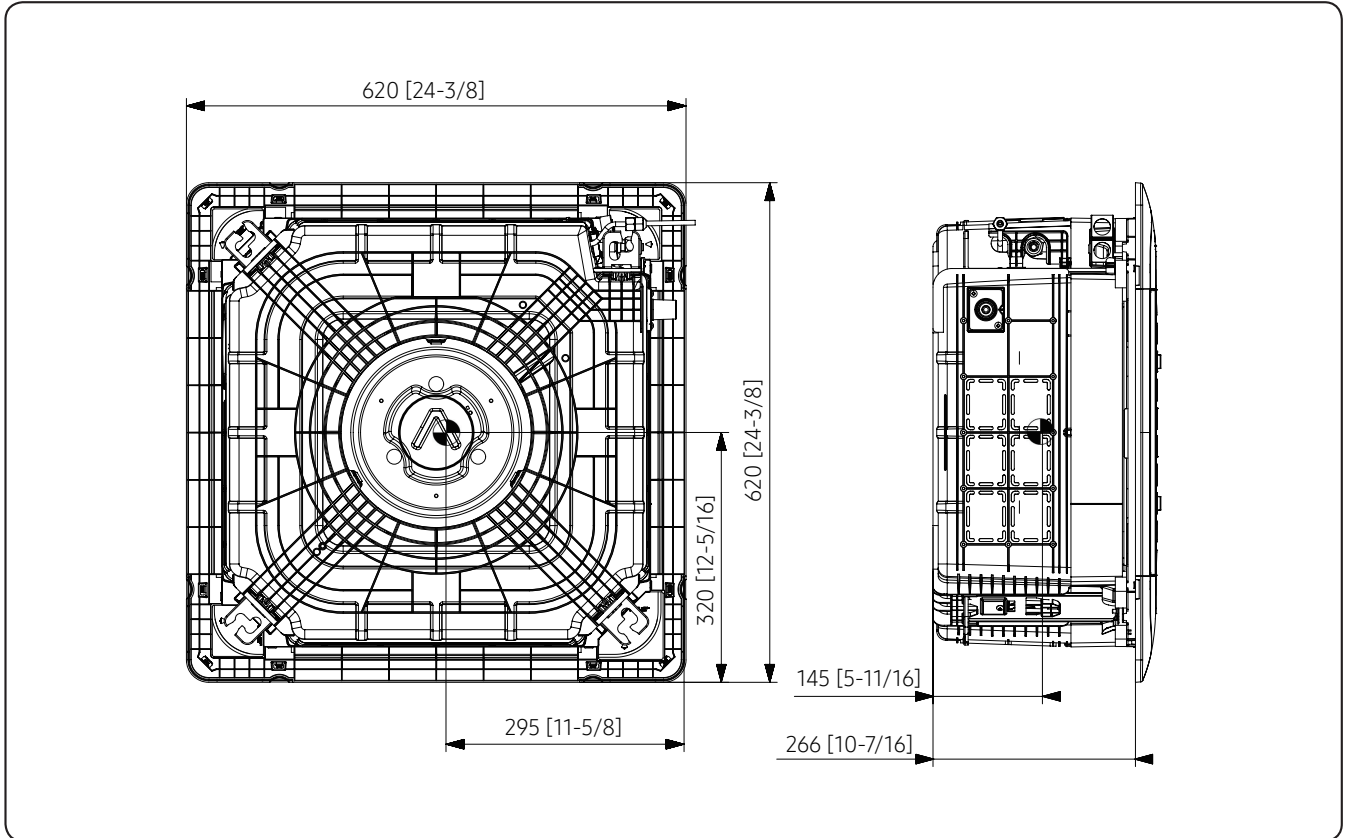

# 6. Electrical Wiring Diagram

## WindFree™ 4Way Cassette (600x600)

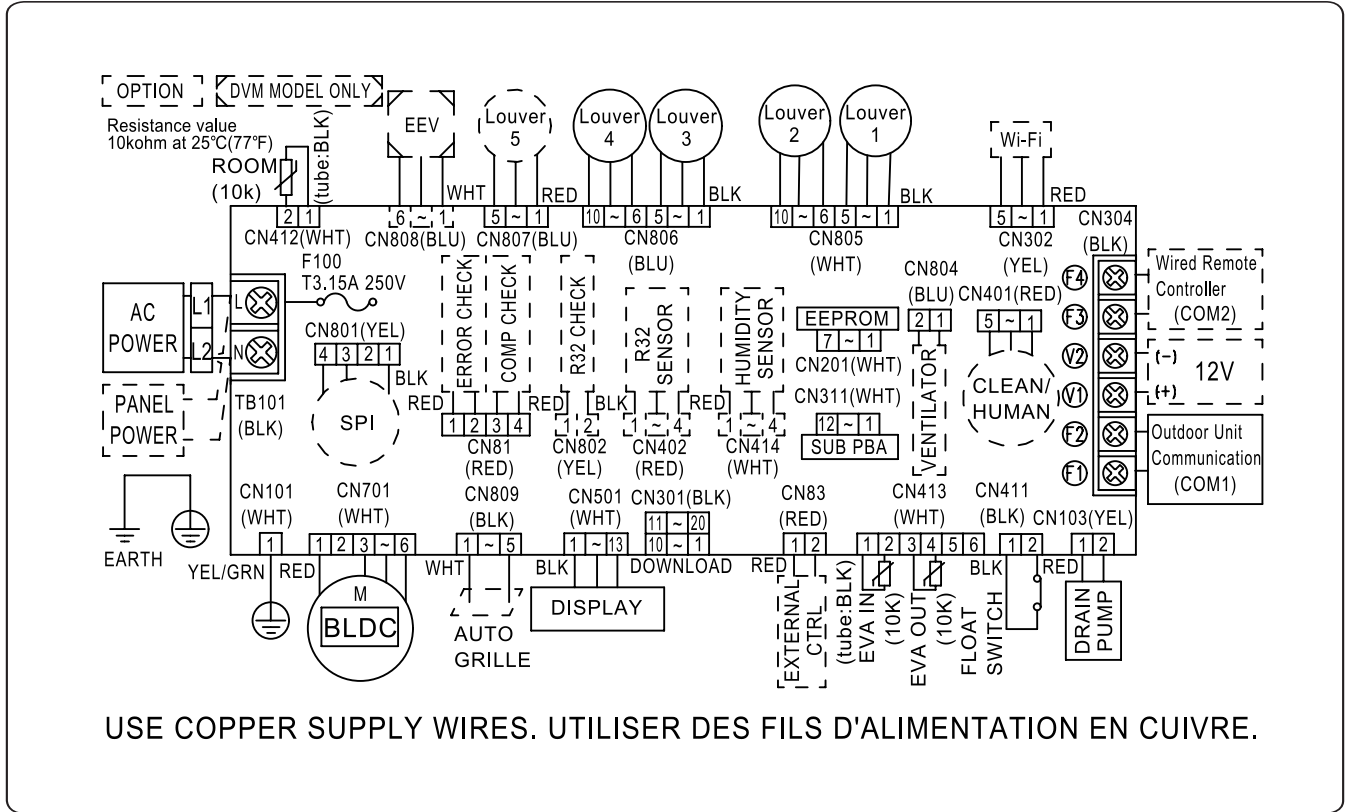

F100	FUSE	EEV	Electronic Expansion Valve	ROOM(10K)	Thermistor ROOM OUT(10K)
M-BLDC	BLDC Motor	EXT_CONTROL	EXTERNAL_CONTROL	EVA-IN(10K)	Thermistor EVA IN(10K)
				EVA-OUT(10K)	Thermistor EVA OUT(10K)

### NOTE

- This wiring diagram applies only to the Indoor unit.
- Symbols show as follow :  
blk: black, red: red, blu: blue, wht: white, yel: yellow, brn: brown, sky: skyblue: grn: green
- For connection wiring indoor-outdoor transmission F1-F2, indoor-wired remote controller transmission F3-F4.
- Protective earth(screw), : connector, : The wire quantity

# 7. Sound Data

## WindFree™ 4Way Cassette (600x600)

### Sound Pressure level

Unit: dB(A)

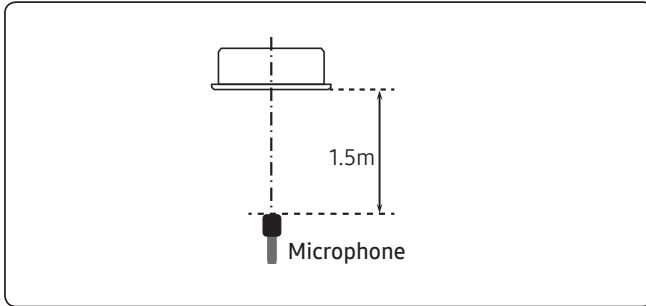

Model	High	MID	LOW	Windfree
AM015DNNDKG/EU	30	28	23	23
AM022DNNDKG/EU	32	29	25	25
AM028DNNDKG/EU	33	30	26	26
AM036DNNDKG/EU	34	30	26	26

- NR Curve

1) AM015DNNDKG/EU

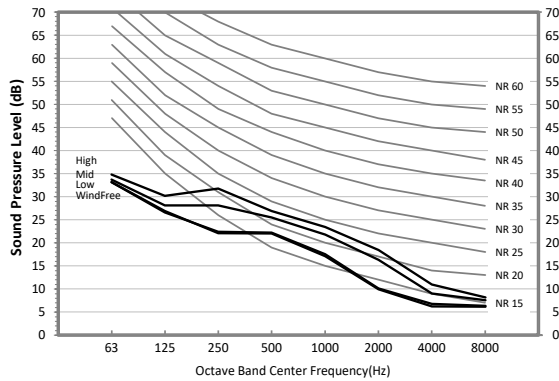

2) AM022DNNDKG/EU

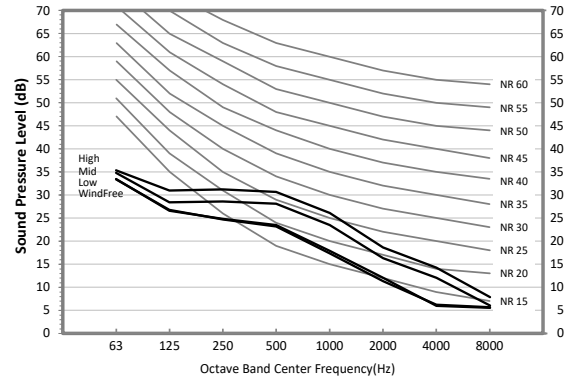

3) AM028DNNDKG/EU

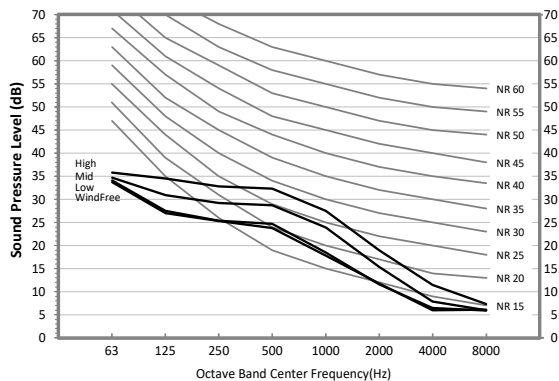

4) AM036DNNDKG/EU

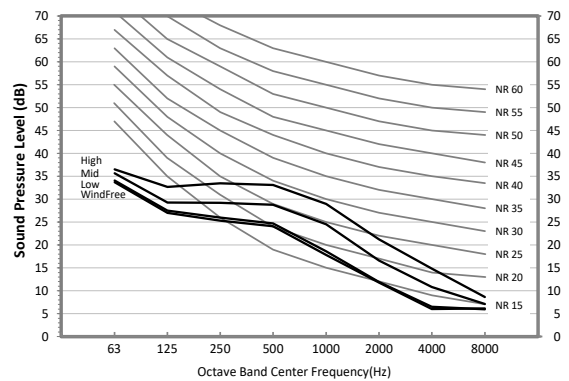

### NOTE

- Specifications may be subject to change without prior notice.
  - Sound pressure level is obtained in an anechoic room.
  - Sound pressure level is a relative value, depending on the distance and acoustic environment.
  - Sound pressure level may differ depending on operation condition.
  - dB(A) = A weighted sound pressure level
  - Reference acoustic pressure 0 dB = 20μPa

# 7. Sound Data

## WindFree™ 4Way Cassette (600x600)

### Sound Pressure level

Unit: dB(A)

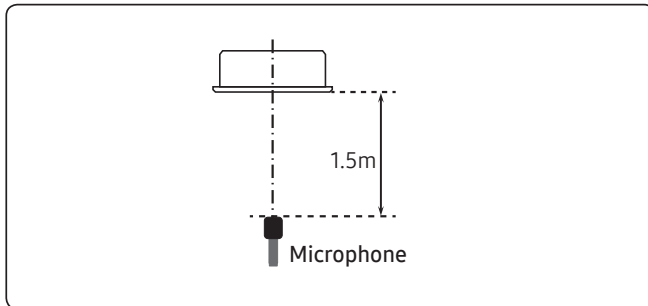

Model	High	MID	LOW	Windfree
AM045DNNDKG/EU	36	34	32	32
AM056DNNDKG/EU	39	36	33	33
AM060DNNDKG/EU	40	38	35	35

- NR Curve

5) AM045DNNDKG/EU

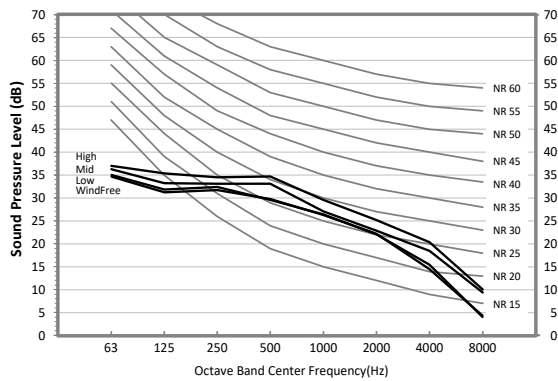

6) AM056DNNDKG/EU

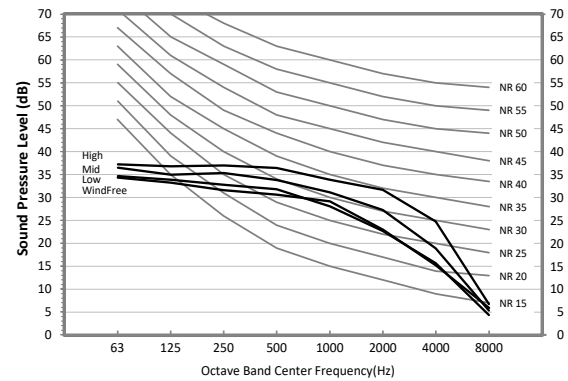

7) AM060DNNDKG/EU

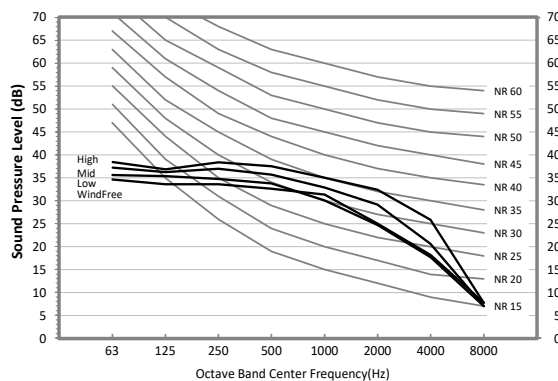

### NOTE

- Specifications may be subject to change without prior notice.
  - Sound pressure level is obtained in an anechoic room.
  - Sound pressure level is a relative value, depending on the distance and acoustic environment.
  - Sound pressure level may differ depending on operation condition.
  - dB(A) = A weighted sound pressure level
  - Reference acoustic pressure 0 dB = 20μPa

# 7. Sound Data

## WindFree™ 4Way Cassette (600x600)

### Sound Power level

#### NOTE

- Specifications may be subject to change without prior notice
  - Sound power level is an absolute value that a sound source generates.
  - dBA = A-weighted sound power level.
  - Reference power : 1pW.
  - Measured according to ISO 3741.

Unit: dB(A)

Model	Power
AM015DNNDKG/EU	46
AM022DNNDKG/EU	47
AM028DNNDKG/EU	50
AM036DNNDKG/EU	51

#### NR Curve

1) AM015DNNDKG/EU

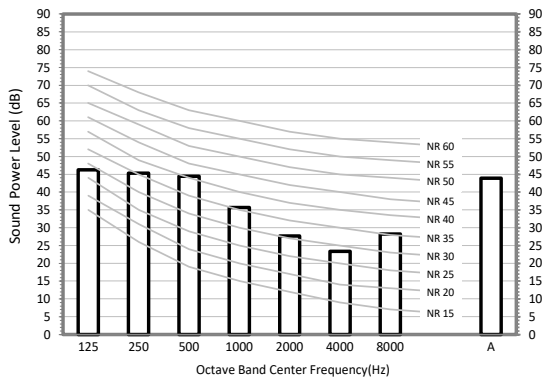

2) AM022DNNDKG/EU

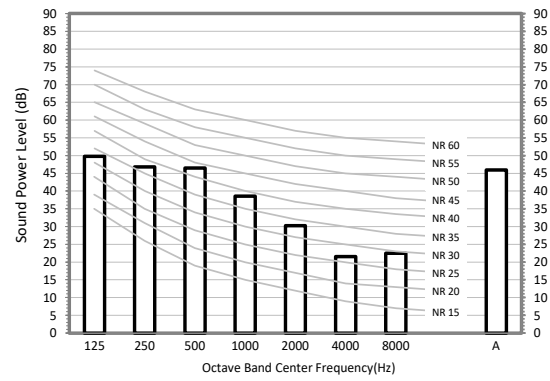

3) AM028DNNDKG/EU

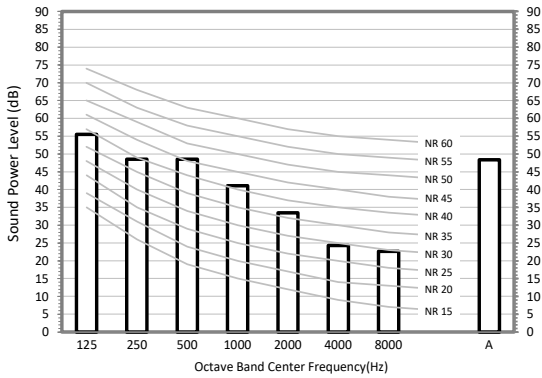

4) AM036DNNDKG/EU

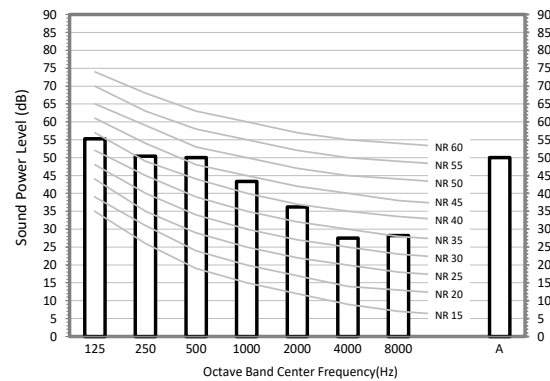

# 7. Sound Data

## WindFree™ 4Way Cassette (600x600)

### Sound Power level

#### NOTE

- Specifications may be subject to change without prior notice
  - Sound power level is an absolute value that a sound source generates.
  - dBA = A-weighted sound power level.
  - Reference power : 1pW.
  - Measured according to ISO 3741.

Unit: dB(A)

Model	Power
AM045DNNDKG/EU	53
AM056DNNDKG/EU	56
AM060DNNDKG/EU	57

#### NR Curve

5) AM045DNNDKG/EU

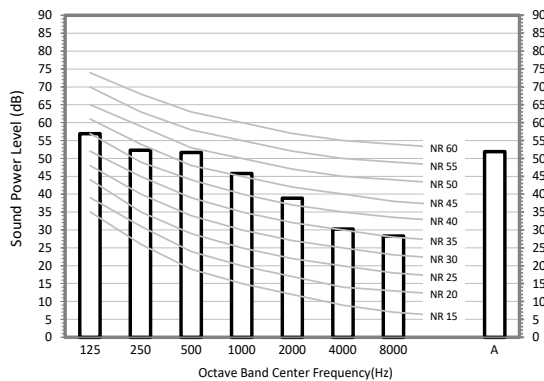

6) AM056DNNDKG/EU

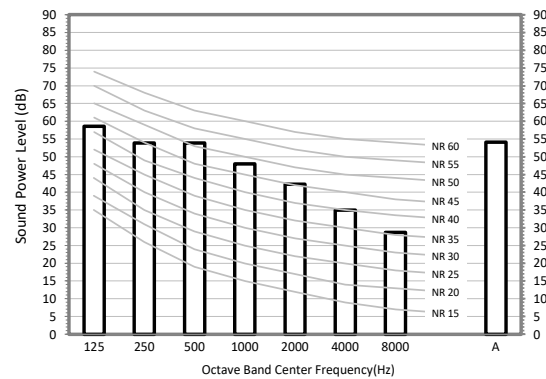

7) AM060DNNDKG/EU

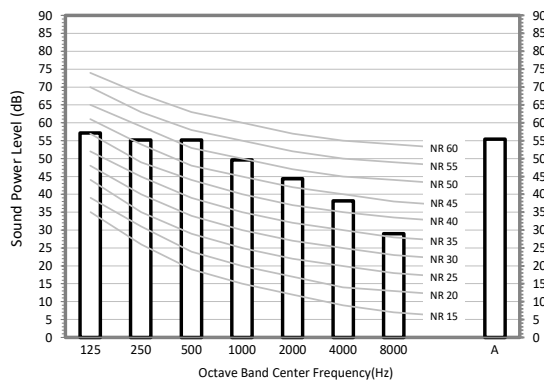

# 8. Temperature and air flow distribution

## WindFree™ 4Way Cassette (600x600)

### AM015DNNDKG/EU

- Cooling Air Velocity distribution  
(Discharge angle : 41 degree)

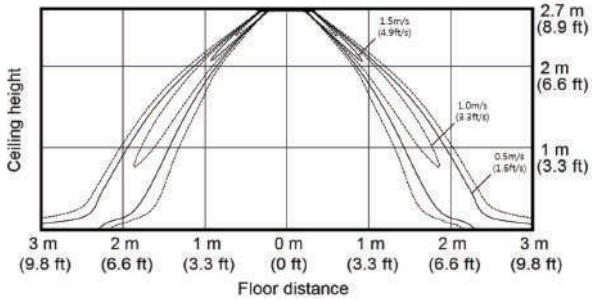

- Cooling temperature distribution  
(Discharge angle : 41 degree)

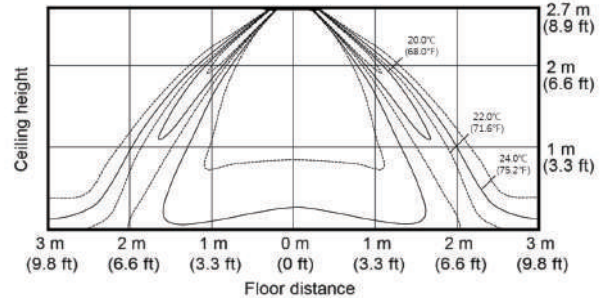

- Heating Air Velocity distribution  
(Discharge angle : 56 degree)

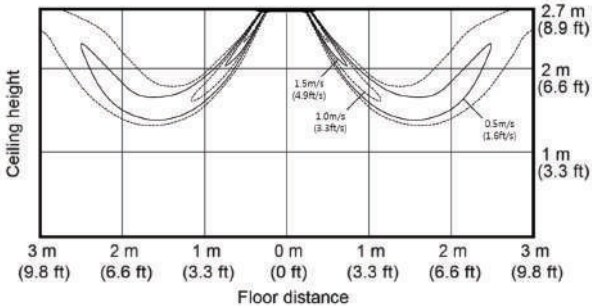

- Heating temperature distribution  
(Discharge angle : 56 degree)

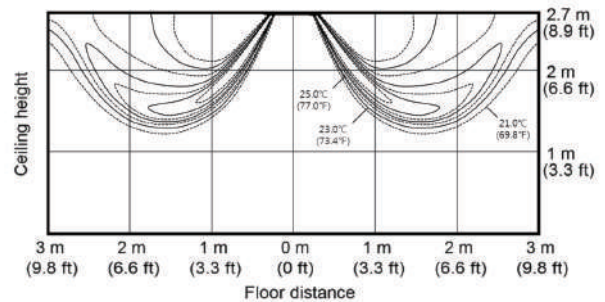

### AM022DNNDKG/EU

- Cooling Air Velocity distribution  
(Discharge angle : 41 degree)

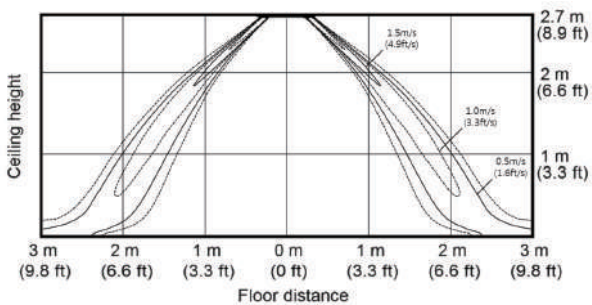

- Cooling temperature distribution  
(Discharge angle : 41 degree)

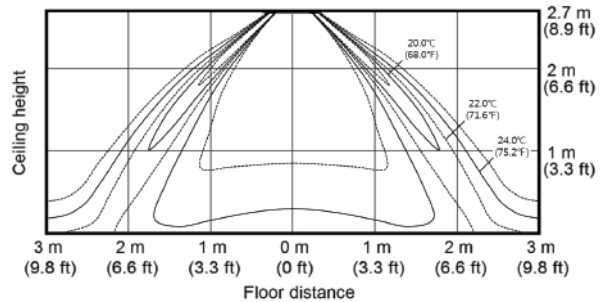

- Heating Air Velocity distribution  
(Discharge angle : 56 degree)

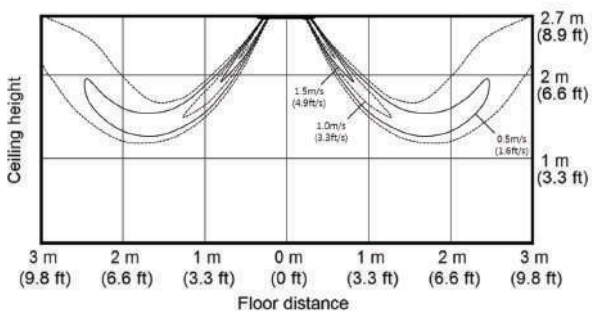

- Heating temperature distribution  
(Discharge angle : 56 degree)

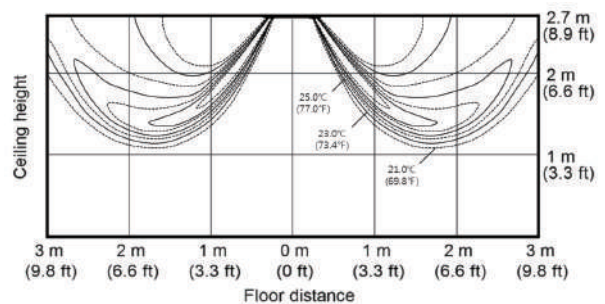

# 8. Temperature and air flow distribution

## WindFree™ 4Way Cassette (600x600)

### AM028DNNDKG/EU

- Cooling Air Velocity distribution  
(Discharge angle : 41 degree)

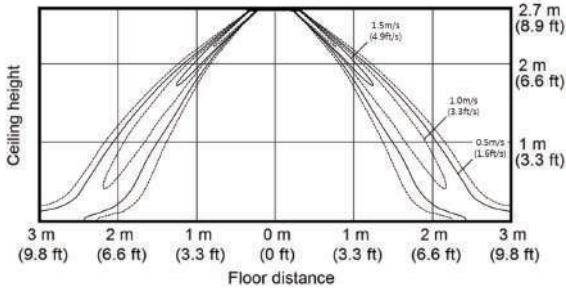

- Cooling temperature distribution  
(Discharge angle : 41 degree)

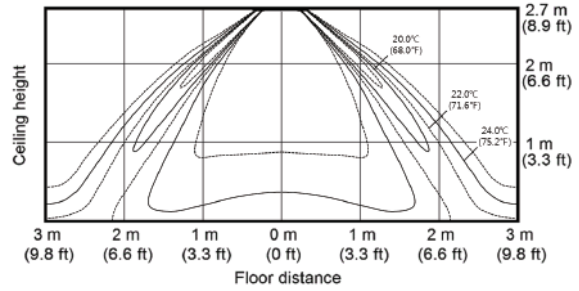

- Heating Air Velocity distribution  
(Discharge angle : 56 degree)

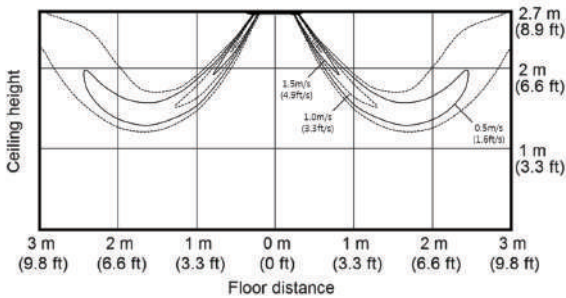

- Heating temperature distribution  
(Discharge angle : 56 degree)

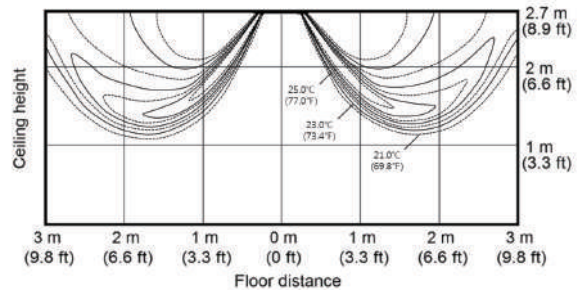

### AM036DNNDKG/EU

- Cooling Air Velocity distribution  
(Discharge angle : 41 degree)

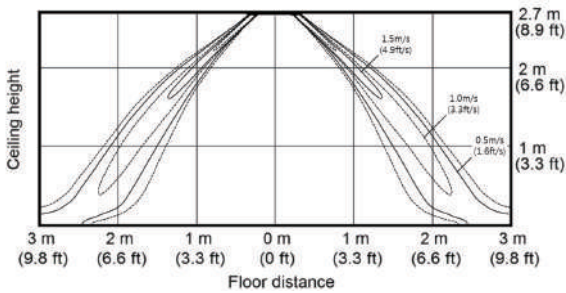

- Cooling temperature distribution  
(Discharge angle : 41 degree)

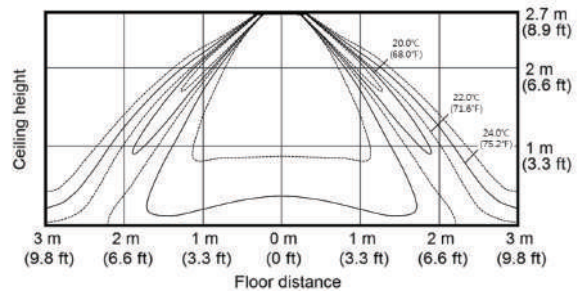

- Heating Air Velocity distribution  
(Discharge angle : 56 degree)

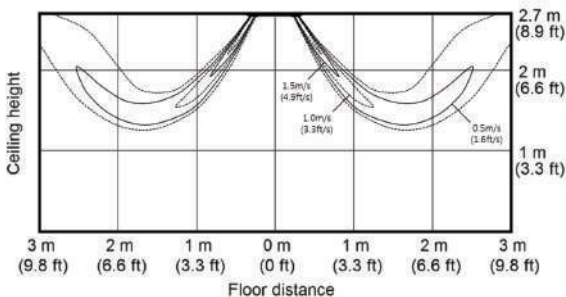

- Heating temperature distribution  
(Discharge angle : 56 degree)

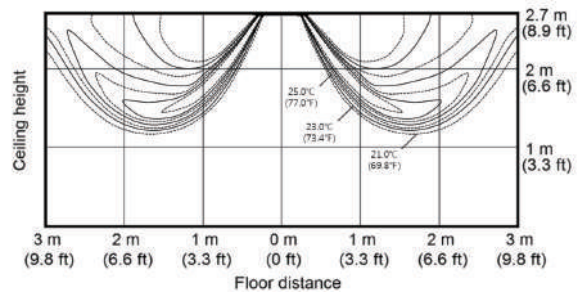

# 8. Temperature and air flow distribution

## WindFree™ 4Way Cassette (600x600)

### AM045DNNDKG/EU

- Cooling Air Velocity distribution  
(Discharge angle : 41 degree)

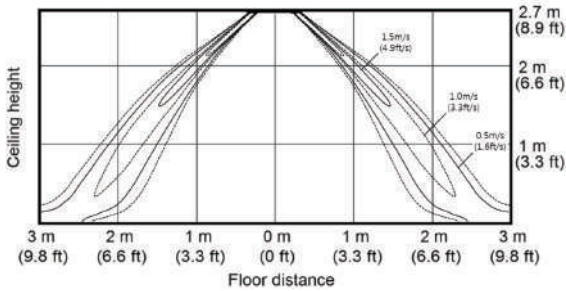

- Cooling temperature distribution  
(Discharge angle : 41 degree)

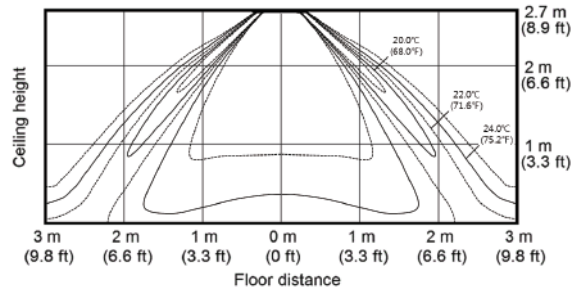

- Heating Air Velocity distribution  
(Discharge angle : 56 degree)

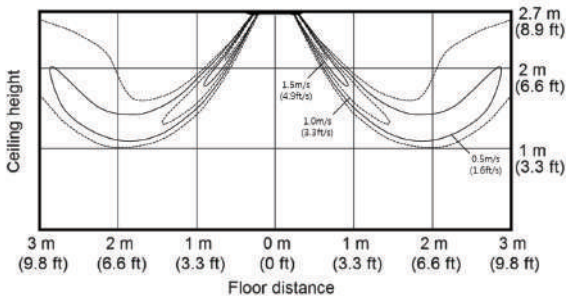

- Heating temperature distribution  
(Discharge angle : 56 degree)

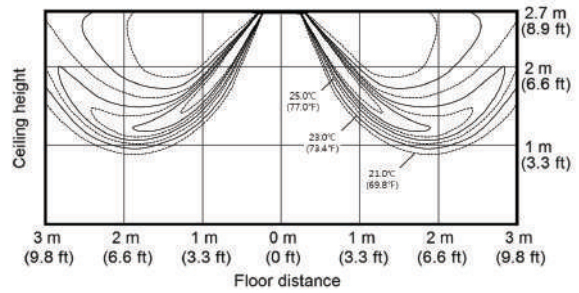

### AM056DNNDKG/EU

- Cooling Air Velocity distribution  
(Discharge angle : 41 degree)

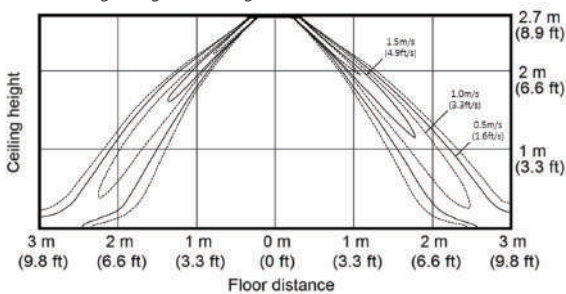

- Cooling temperature distribution  
(Discharge angle : 41 degree)

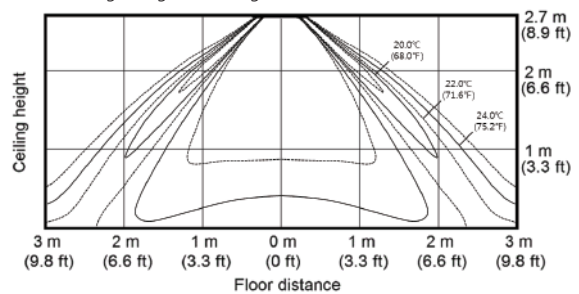

- Heating Air Velocity distribution  
(Discharge angle : 56 degree)

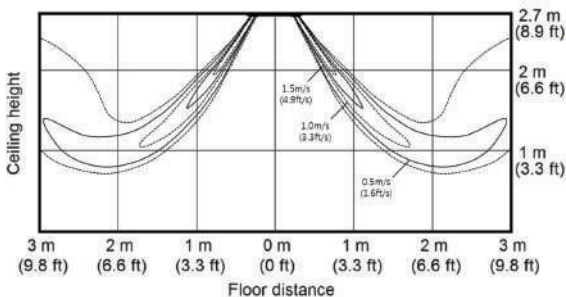

- Heating temperature distribution  
(Discharge angle : 56 degree)

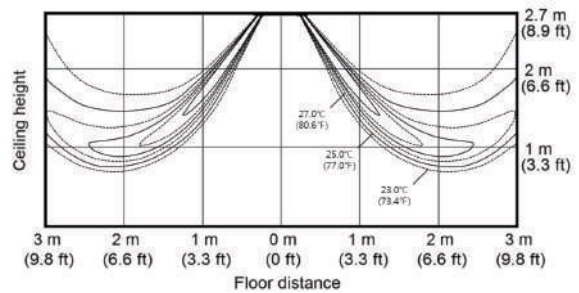

# 8. Temperature and air flow distribution

## WindFree™ 4Way Cassette (600x600)

### AM060DNNDKG/EU

- Cooling Air Velocity distribution  
(Discharge angle : 41 degree)

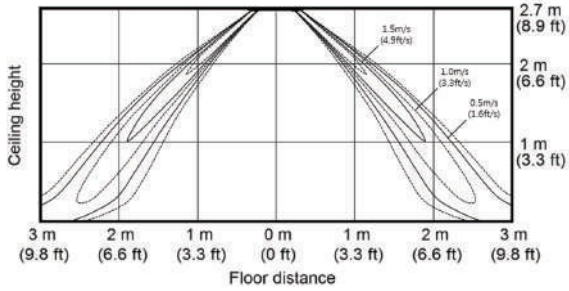

- Cooling temperature distribution  
(Discharge angle : 41 degree)

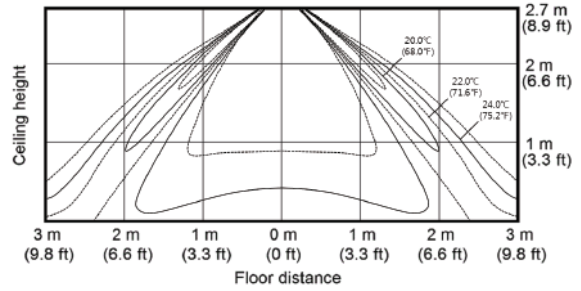

- Heating Air Velocity distribution  
(Discharge angle : 56 degree)

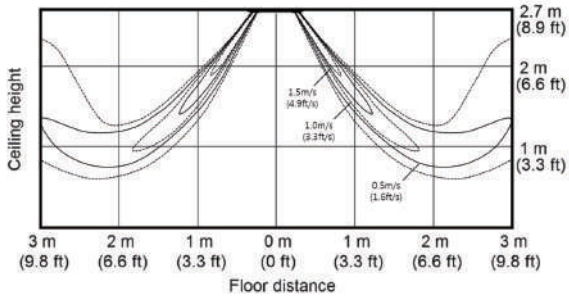

- Heating temperature distribution  
(Discharge angle : 56 degree)

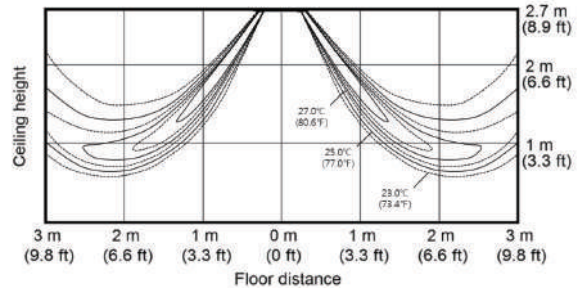

# 9. Piping Diagram

## WindFree™ 4Way Cassette (600x600)

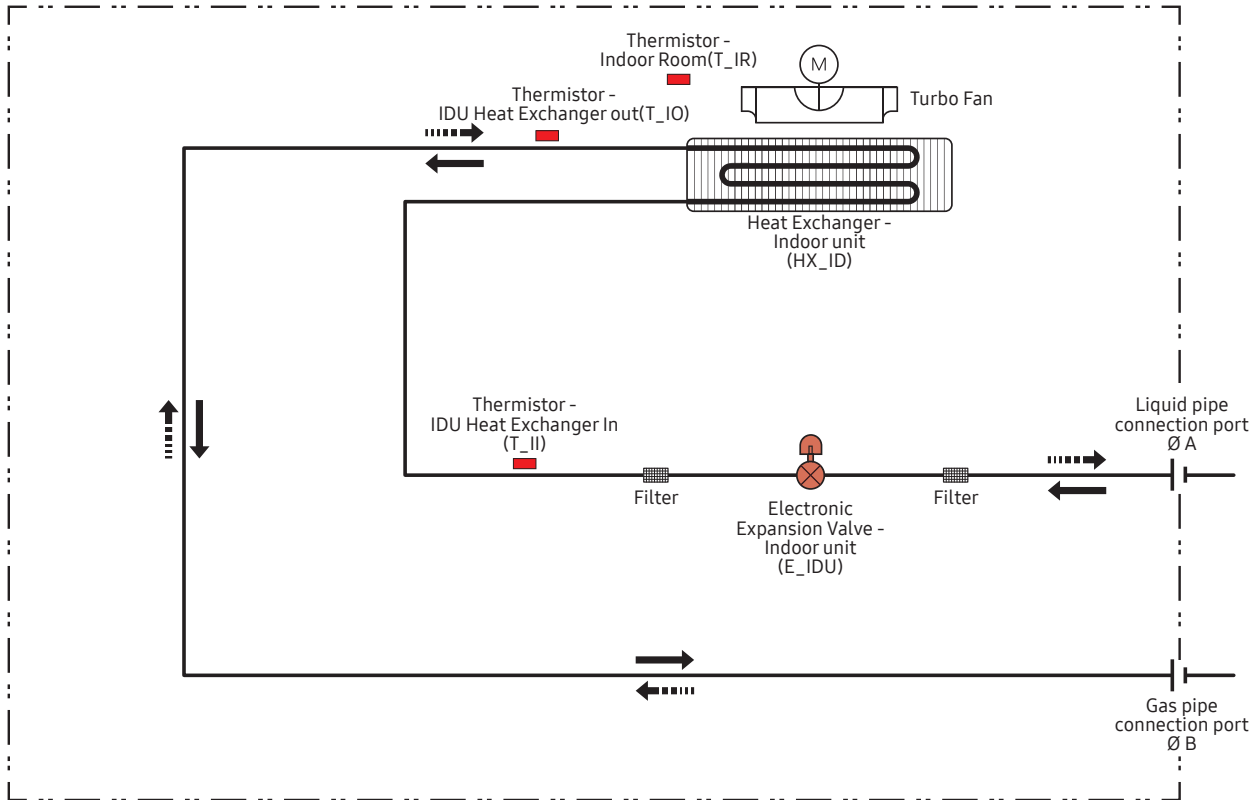

Refrigerant flow	
Cooling	Heating
→	····→

# WindFree™ 4Way Cassette

---

1. Specification	51
2. Summary Table	61
3. Capacity Table	63
4. Dimensional Drawing	64
5. Center of Gravity	67
6. Electrical Wiring Diagram	68
7. Sound Data	69
8. Temperature and air flow distribution	77
9. Piping Diagram	85

---



# Line-up

## WindFree™ 4Way Cassette

### Deluxe

Capacity (kW)								
2.8	3.6	4.5	5.6	7.1	9.0	11.2	12.8	14.0
								

### Flagship

Capacity (kW)					
2.2	2.8	3.6	4.5	5.6	7.1
					

# 1. Specification

## WindFree™ 4Way Cassette

Model Name				AM028DN4DKG/EU	AM036DN4DKG/EU	AM045DN4DKG/EU
Power Supply			Φ, #, V, Hz	1,2,220-240,50/60	1,2,220-240,50/60	1,2,220-240,50/60
Performance	Capacity	Cooling	kW	2.80	3.60	4.50
			Btu/h	9,600	12,300	15,400
		Heating	kW	3.20	4.00	5.00
			Btu/h	10,900	13,600	17,100
Power	Power Input	Cooling	W	24.00	26.00	28.00
		Heating		24.00	26.00	28.00
	Current Input	Cooling	A	0.25	0.27	0.30
		Heating		0.25	0.27	0.30
	Current	MCA	A	0.33	0.36	0.40
		MFA		15	15	15
Heat exchanger	Type		-	Fin & Tube	Fin & Tube	Fin & Tube
	Material	Fin	-	Al	Al	Al
		Tube	-	Cu	Cu	Cu
	Fin Treatment		-	Green Hydrophile	Green Hydrophile	Green Hydrophile
Fan	Type	Type	-	Turbo Fan	Turbo Fan	Turbo Fan
	Quantity		ea	1	1	1
	Air Flow Rate	H/M/L	CMM	14.4 / 13.4 / 12.4	15.4 / 14.4 / 13.4	16.3 / 15.4 / 14.4
l/s			240.0 / 223.3 / 206.7	255.0 / 240.0 / 223.3	271.7 / 256.7 / 240.0	
Fan Motor	Model		-	BLDC Motor	BLDC Motor	BLDC Motor
	Output x n		W	65 x 1	65 x 1	65 x 1
Piping Connections	Liquid Pipe	Type		Flare connection	Flare connection	Flare connection
		Φ,mm		6.35	6.35	6.35
		Φ, inch		1/4	1/4	1/4
	Gas Pipe	Type		Flare connection	Flare connection	Flare connection
		Φ,mm		12.70	12.70	12.70
		Φ, inch		1/2	1/2	1/2
	Heat insulation		-	Both liquid & gas pipes	Both liquid & gas pipes	Both liquid & gas pipes
Drain Pipe		Φ,mm	VP25 (OD 32,ID 25)	VP25 (OD 32,ID 25)	VP25 (OD 32,ID 25)	
Wiring connections	Communication	Min.	mm <sup>2</sup>	0.75	0.75	0.75
		Remark	-	F1, F2	F1, F2	F1, F2
Refrigerant	Type		-	R32	R32	R32
	Electronic Expansion Valve		-	EEV INCLUDED	EEV INCLUDED	EEV INCLUDED
Sound	Sound Pressure	H/M/L/W	dB(A)	30 / 28 / 27 / 27	31 / 30 / 28 / 28	33 / 31 / 29 / 29
	Sound Power	Cooling		46	47	49
Dimensions	Net Weight		kg	15.0	15.0	15.0
	Shipping Weight		kg	18.5	18.5	19.0
	Net Dimensions (W×H×D)		mm	840 x 204 x 840	840 x 204 x 840	840 x 204 x 840
	Shipping Dimensions (W×H×D)		mm	898 x 275 x 898	898 x 275 x 898	898 x 275 x 898

# 1. Specification

## WindFree™ 4Way Cassette

Model Name			AM028DN4DKG/EU	AM036DN4DKG/EU	AM045DN4DKG/EU
Panel	Model Name	-	PC4NUFMANW	PC4NUFMANW	PC4NUFMANW
	Type	-	Wind-Free Type	Wind-Free Type	Wind-Free Type
	Material	-	HIPS	HIPS	HIPS
	Color	-	White	White	White
	Net Weight	kg	6.2	6.2	6.2
	Shipping Weight	kg	8.4	8.4	8.4
	Net Dimensions (W×H×D)	mm	950 x 48 x 950	950 x 48 x 950	950 x 48 x 950
	Shipping Dimensions (W×H×D)	mm	1,010 x 117 x 1,000	1,010 x 117 x 1,000	1,010 x 117 x 1,000
Drain Pump	Drain Pump	-	INCLUDED	INCLUDED	INCLUDED
	Max. lifting Height / Displacement	mm / Liter/h	750 / 24	750 / 24	750 / 24

### NOTE

- Specification may be subject to change without prior notice.
  - 1) Capacities are based on (Equivalent refrigerant piping 7.5m, Level differences 0m);
    - Cooling : Indoor temperature 27°C DB, 19°C WB / Outdoor temperature 35°C DB, 24°C WB
    - Heating : Indoor temperature 20°C DB, 15°C WB / Outdoor temperature 7°C DB, 6°C WB
  - 2) Sound level was acquired in an anechoic room. Thus actual noise level may be different depending on the installation conditions.
  - 3) These products contain R32 (GWP=675) which is fluorinated greenhouse gas.
  - 4) Select wire size based on the value of MCA

# 1. Specification

## WindFree™ 4Way Cassette

Model Name				AM056DN4DKG/EU	AM071DN4DKG/EU	AM090DN4DKG/EU
Power Supply			Φ, #, V, Hz	1,2,220-240,50/60	1,2,220-240,50/60	1,2,220-240,50/60
Performance	Capacity	Cooling	kW	5.60	7.10	9.00
			Btu/h	19,100	24,200	30,700
		Heating	kW	6.30	8.00	10.00
			Btu/h	21,500	27,300	34,100
Power	Power Input	Cooling	W	32.00	34.00	55.00
		Heating		32.00	34.00	55.00
	Current Input	Cooling	A	0.32	0.35	0.45
		Heating		0.32	0.35	0.45
	Current	MCA	A	0.43	0.47	0.60
		MFA		15	15	15
Heat exchanger	Type		-	Fin & Tube	Fin & Tube	Fin & Tube
	Material	Fin	-	Al	Al	Al
		Tube	-	Cu	Cu	Cu
	Fin Treatment		-	Green Hydrophile	Green Hydrophile	Green Hydrophile
Fan	Type	Type	-	Turbo Fan	Turbo Fan	Turbo Fan
	Quantity		ea	1	1	1
	Air Flow Rate	H/M/L	CMM	16.4 / 14.6 / 12.8	18.2 / 15.4 / 12.8	24.4 / 19.9 / 15.5
			l/s	273.3 / 243.3 / 213.3	303.3 / 256.7 / 213.3	406.7 / 331.7 / 258.3
Fan Motor	Model		-	BLDC Motor	BLDC Motor	BLDC Motor
	Output x n		W	65 x 1	65 x 1	65 x 1
Piping Connections	Liquid Pipe	Type		Flare connection	Flare connection	Flare connection
		Φ,mm		6.35	9.52	9.52
		Φ, inch		1/4	3/8	3/8
	Gas Pipe	Type		Flare connection	Flare connection	Flare connection
		Φ,mm		12.70	15.88	15.88
		Φ, inch		1/2	5/8	5/8
	Heat insulation		-	Both liquid & gas pipes	Both liquid & gas pipes	Both liquid & gas pipes
	Drain Pipe		Φ,mm	VP25 (OD 32,ID 25)	VP25 (OD 32,ID 25)	VP25 (OD 32,ID 25)
Wiring connections	Communication	Min.	mm <sup>2</sup>	0.75	0.75	0.75
		Remark	-	F1, F2	F1, F2	F1, F2
Refrigerant	Type		-	R32	R32	R32
	Electronic Expansion Valve		-	EEV INCLUDED	EEV INCLUDED	EEV INCLUDED
Sound	Sound Pressure	H/M/L/W	dB(A)	35 / 33 / 29 / 29	37 / 34 / 30 / 30	39 / 35 / 30 / 30
	Sound Power	Cooling		51	53	55
Dimensions	Net Weight		kg	16.5	16.5	18.0
	Shipping Weight		kg	20.5	20.5	22.0
	Net Dimensions (W×H×D)		mm	840 x 204 x 840	840 x 204 x 840	840 x 246 x 840
	Shipping Dimensions (W×H×D)		mm	898 x 275 x 898	898 x 275 x 898	898 x 316 x 898

# 1. Specification

## WindFree™ 4Way Cassette

Model Name			AM056DN4DKG/EU	AM071DN4DKG/EU	AM090DN4DKG/EU
Panel	Model Name	-	PC4NUFMANW	PC4NUFMANW	PC4NUFMANW
	Type	-	Wind-Free Type	Wind-Free Type	Wind-Free Type
	Material	-	HIPS	HIPS	HIPS
	Color	-	White	White	White
	Net Weight	kg	6.2	6.2	6.2
	Shipping Weight	kg	8.4	8.4	8.4
	Net Dimensions (W×H×D)	mm	950 x 48 x 950	950 x 48 x 950	950 x 48 x 950
	Shipping Dimensions (W×H×D)	mm	1,010 x 117 x 1,000	1,010 x 117 x 1,000	1,010 x 117 x 1,000
Drain Pump	Drain Pump	-	INCLUDED	INCLUDED	INCLUDED
	Max. lifting Height / Displacement	mm / Liter/h	750 / 24	750 / 24	750 / 24

### NOTE

- Specification may be subject to change without prior notice.
  - 1) Capacities are based on (Equivalent refrigerant piping 7.5m, Level differences 0m);
    - Cooling : Indoor temperature 27°C DB, 19°C WB / Outdoor temperature 35°C DB, 24°C WB
    - Heating : Indoor temperature 20°C DB, 15°C WB / Outdoor temperature 7°C DB, 6°C WB
  - 2) Sound level was acquired in an anechoic room. Thus actual noise level may be different depending on the installation conditions.
  - 3) These products contain R32 (GWP=675) which is fluorinated greenhouse gas.
  - 4) Select wire size based on the value of MCA

# 1. Specification

## WindFree™ 4Way Cassette

Model Name				AM112DN4DKG/EU	AM128DN4DKG/EU	AM140DN4DKG/EU
Power Supply			Φ, #, V, Hz	1,2,220-240,50/60	1,2,220-240,50/60	1,2,220-240,50/60
Performance	Capacity	Cooling	kW	11.20	12.80	14.00
			Btu/h	38,200	43,700	47,800
		Heating	kW	12.50	13.80	16.00
			Btu/h	42,700	47,100	54,600
Power	Power Input	Cooling	W	78.00	95.00	115.00
		Heating		78.00	95.00	115.00
	Current Input	Cooling	A	0.60	0.75	0.85
		Heating		0.60	0.75	0.85
	Current	MCA	A	0.80	1.00	1.13
		MFA		15	15	15
Heat exchanger	Type		-	Fin & Tube	Fin & Tube	Fin & Tube
	Material	Fin	-	Al	Al	Al
		Tube	-	Cu	Cu	Cu
Fin Treatment			-	Green Hydrophile	Green Hydrophile	Green Hydrophile
Fan	Type	Type	-	Turbo Fan	Turbo Fan	Turbo Fan
	Quantity		ea	1	1	1
	Air Flow Rate	H/M/L	CMM	26.6 / 21.0 / 15.5	35.4 / 29.2 / 24.3	37.9 / 31.7 / 25.5
l/s			443.3 / 350.0 / 258.3	590 / 486.7 / 405	631.7 / 528.3 / 425	
Fan Motor	Model		-	BLDC Motor	BLDC Motor	BLDC Motor
	Output x n		W	65 x 1	97 x 1	97 x 1
Piping Connections	Liquid Pipe	Type		Flare connection	Flare connection	Flare connection
		Φ,mm		9.52	9.52	9.52
		Φ, inch		3/8	3/8	3/8
	Gas Pipe	Type		Flare connection	Flare connection	Flare connection
		Φ,mm		15.88	15.88	15.88
		Φ, inch		5/8	5/8	5/8
	Heat insulation			-	Both liquid & gas pipes	Both liquid & gas pipes
Drain Pipe			Φ,mm	VP25 (OD 32,ID 25)	VP25 (OD 32,ID 25)	VP25 (OD 32,ID 25)
Wiring connections	Communication	Min.	mm <sup>2</sup>	0.75	0.75	0.75
		Remark	-	F1, F2	F1, F2	F1, F2
Refrigerant	Type		-	R32	R32	R32
	Electronic Expansion Valve		-	EEV INCLUDED	EEV INCLUDED	EEV INCLUDED
Sound	Sound Pressure	H/M/L/W	dB(A)	41 / 36 / 30 / 30	42 / 37 / 35 / 35	44 / 39 / 35 / 35
	Sound Power	Cooling		59	58	60
Dimensions	Net Weight		kg	19.0	21.5	22.5
	Shipping Weight		kg	23.0	25.5	26.5
	Net Dimensions (W×H×D)		mm	840 x 246 x 840	840 x 288 x 840	840 x 288 x 840
	Shipping Dimensions (W×H×D)		mm	898 x 316 x 898	898 x 357 x 898	898 x 357 x 898

# 1. Specification

## WindFree™ 4Way Cassette

Model Name			AM112DN4DKG/EU	AM128DN4DKG/EU	AM140DN4DKG/EU
Panel	Model Name	-	PC4NUFMANW	PC4NUFMANW	PC4NUFMANW
	Type	-	Wind-Free Type	Wind-Free Type	Wind-Free Type
	Material	-	HIPS	HIPS	HIPS
	Color	-	White	White	White
	Net Weight	kg	6.2	6.2	6.2
	Shipping Weight	kg	8.4	8.4	8.4
	Net Dimensions (W×H×D)	mm	950 x 48 x 950	950 x 48 x 950	950 x 48 x 950
	Shipping Dimensions (W×H×D)	mm	1,010 x 117 x 1,000	1,010 x 117 x 1,000	1,010 x 117 x 1,000
Drain Pump	Drain Pump	-	INCLUDED	INCLUDED	INCLUDED
	Max. lifting Height / Displacement	mm / Liter/h	750 / 24	750 / 24	750 / 24

### NOTE

- Specification may be subject to change without prior notice.
  - 1) Capacities are based on (Equivalent refrigerant piping 7.5m, Level differences 0m);
    - Cooling : Indoor temperature 27°C DB, 19°C WB / Outdoor temperature 35°C DB, 24°C WB
    - Heating : Indoor temperature 20°C DB, 15°C WB / Outdoor temperature 7°C DB, 6°C WB
  - 2) Sound level was acquired in an anechoic room. Thus actual noise level may be different depending on the installation conditions.
  - 3) These products contain R32 (GWP=675) which is fluorinated greenhouse gas.
  - 4) Select wire size based on the value of MCA

# 1. Specification

## WindFree™ 4Way Cassette

Model Name				AM022DN4FKG/EU	AM028DN4FKG/EU	AM036DN4FKG/EU
Power Supply			Φ, #, V, Hz	1,2,220-240,50/60	1,2,220-240,50/60	1,2,220-240,50/60
Performance	Capacity	Cooling	kW	2.20	2.80	3.60
			Btu/h	7,500	9,600	12,300
		Heating	kW	2.50	3.20	4.00
			Btu/h	8,500	10,900	13,600
Power	Power Input	Cooling	W	17.00	20.00	27.00
		Heating		17.00	20.00	27.00
	Current Input	Cooling	A	0.14	0.17	0.23
		Heating		0.14	0.17	0.23
	Current	MCA	A	0.29	0.33	0.41
		MFA		15	15	15
Heat exchanger	Type		-	Fin & Tube	Fin & Tube	Fin & Tube
	Material	Fin	-	Al	Al	Al
		Tube	-	Cu	Cu	Cu
	Fin Treatment		-	Green Hydrophile	Green Hydrophile	Green Hydrophile
Fan	Type	Type	-	Turbo Fan	Turbo Fan	Turbo Fan
	Quantity		ea	1	1	1
	Air Flow Rate	H/M/L	CMM	13.0 / 12.0 / 11.0	14.0 / 13.0 / 12.0	16.0 / 15.0 / 14.0
			l/s	217 / 200 / 183	233 / 217 / 200	267 / 250 / 233
Fan Motor	Model		-	BLDC Motor	BLDC Motor	BLDC Motor
	Output x n		W	65 x 1	65 x 1	65 x 1
Piping Connections	Liquid Pipe	Type		Flare connection	Flare connection	Flare connection
		Φ,mm		6.35	6.35	6.35
		Φ, inch		1/4	1/4	1/4
	Gas Pipe	Type		Flare connection	Flare connection	Flare connection
		Φ,mm		12.7	12.7	12.7
		Φ, inch		1/2	1/2	1/2
	Heat insulation		-	Both liquid & gas pipes	Both liquid & gas pipes	Both liquid & gas pipes
Drain Pipe		Φ,mm	VP25 (OD 32,ID 25)	VP25 (OD 32,ID 25)	VP25 (OD 32,ID 25)	
Wiring connections	Communication	Min.	mm <sup>2</sup>	0.75	0.75	0.75
		Remark	-	F1, F2	F1, F2	F1, F2
Refrigerant	Type		-	R32	R32	R32
	Electronic Expansion Valve		-	EEV INCLUDED	EEV INCLUDED	EEV INCLUDED
Sound	Sound Pressure	H/M/L/W	dB(A)	32 / 30 / 29 / 29	33 / 31 / 30 / 30	34 / 33 / 31 / 31
	Sound Power	Cooling		48	49	50
Dimensions	Net Weight		kg	18.0	18.0	18.0
	Shipping Weight		kg	22.0	22.0	22.0
	Net Dimensions (W×H×D)		mm	840 x 246 x 840	840 x 246 x 840	840 x 246 x 840
	Shipping Dimensions (W×H×D)		mm	898 x 316 x 898	898 x 316 x 898	898 x 316 x 898

# 1. Specification

## WindFree™ 4Way Cassette

Model Name			AM022DN4FKG/EU	AM028DN4FKG/EU	AM036DN4FKG/EU
Panel	Model Name	-	PC4NUFMANW	PC4NUFMANW	PC4NUFMANW
	Type	-	Wind-Free Type	Wind-Free Type	Wind-Free Type
	Material	-	HIPS	HIPS	HIPS
	Color	-	White	White	White
	Net Weight	kg	6.2	6.2	6.2
	Shipping Weight	kg	8.4	8.4	8.4
	Net Dimensions (W×H×D)	mm	950 x 48 x 950	950 x 48 x 950	950 x 48 x 950
	Shipping Dimensions (W×H×D)	mm	1,010 x 117 x 1,000	1,010 x 117 x 1,000	1,010 x 117 x 1,000
Drain Pump	Drain Pump	-	INCLUDED	INCLUDED	INCLUDED
	Max. lifting Height / Displacement	mm / Liter/h	750 / 24	750 / 24	750 / 24

### NOTE

- Specification may be subject to change without prior notice.
  - 1) Capacities are based on (Equivalent refrigerant piping 7.5m, Level differences 0m);
    - Cooling : Indoor temperature 27°C DB, 19°C WB / Outdoor temperature 35°C DB, 24°C WB
    - Heating : Indoor temperature 20°C DB, 15°C WB / Outdoor temperature 7°C DB, 6°C WB
  - 2) Sound level was acquired in an anechoic room. Thus actual noise level may be different depending on the installation conditions.
  - 3) These products contain R32 (GWP=675) which is fluorinated greenhouse gas.
  - 4) Select wire size based on the value of MCA

# 1. Specification

## WindFree™ 4Way Cassette

Model Name				AM045DN4FKG/EU	AM056DN4FKG/EU	AM071DN4FKG/EU
Power Supply			Φ, #, V, Hz	1,2,220-240,50/60	1,2,220-240,50/60	1,2,220-240,50/60
Performance	Capacity	Cooling	kW	4.50	5.60	7.10
			Btu/h	15,400	19,100	24,200
		Heating	kW	5.00	6.30	8.00
			Btu/h	17,100	21,500	27,300
Power	Power Input	Cooling	W	35.00	49.00	75.00
		Heating		35.00	49.00	75.00
	Current Input	Cooling	A	0.29	0.38	0.58
		Heating		0.29	0.38	0.58
	Current	MCA	A	0.49	0.57	0.56
		MFA		15	15	15
Heat exchanger	Type		-	Fin & Tube	Fin & Tube	Fin & Tube
	Material	Fin	-	Al	Al	Al
		Tube	-	Cu	Cu	Cu
	Fin Treatment		-	Green Hydrophile	Green Hydrophile	Green Hydrophile
Fan	Type	Type	-	Turbo Fan	Turbo Fan	Turbo Fan
	Quantity		ea	1	1	1
	Air Flow Rate	H/M/L	CMM	18.0 / 16.0 / 14.0	24.0 / 21.0 / 19.0	31.0 / 26.0 / 21.0
			l/s	300 / 267 / 233	400 / 350 / 317	517 / 433 / 350
Fan Motor	Model		-	BLDC Motor	BLDC Motor	BLDC Motor
	Output x n		W	65 x 1	97 x 1	97 x 1
Piping Connections	Liquid Pipe	Type		Flare connection	Flare connection	Flare connection
		Φ,mm		6.35	6.35	9.52
		Φ, inch		1/4	1/4	3/8
	Gas Pipe	Type		Flare connection	Flare connection	Flare connection
		Φ,mm		12.7	12.7	15.88
		Φ, inch		1/2	1/2	5/8
	Heat insulation		-	Both liquid & gas pipes	Both liquid & gas pipes	Both liquid & gas pipes
	Drain Pipe		Φ,mm	VP25 (OD 32,ID 25)	VP25 (OD 32,ID 25)	VP25 (OD 32,ID 25)
Wiring connections	Communication	Min.	mm <sup>2</sup>	0.75	0.75	0.75
		Remark	-	F1, F2	F1, F2	F1, F2
Refrigerant	Type		-	R32	R32	R32
	Electronic Expansion Valve		-	EEV INCLUDED	EEV INCLUDED	EEV INCLUDED
Sound	Sound Pressure	H/M/L/W	dB(A)	34 / 32 / 30 / 30	35 / 33 / 29 / 29	39 / 36 / 32 / 32
	Sound Power	Cooling		50	51	55
Dimensions	Net Weight		kg	18.0	21.5	22.5
	Shipping Weight		kg	22.0	25.5	26.5
	Net Dimensions (W×H×D)		mm	840 x 246 x 840	840 x 288 x 840	840 x 288 x 840
	Shipping Dimensions (W×H×D)		mm	898 x 316 x 898	898 x 357 x 898	898 x 357 x 898

# 1. Specification

## WindFree™ 4Way Cassette

Model Name			AM045DN4FKG/EU	AM056DN4FKG/EU	AM071DN4FKG/EU
Panel	Model Name	-	PC4NUFMANW	PC4NUFMANW	PC4NUFMANW
	Type	-	Wind-Free Type	Wind-Free Type	Wind-Free Type
	Material	-	HIPS	HIPS	HIPS
	Color	-	White	White	White
	Net Weight	kg	6.2	6.2	6.2
	Shipping Weight	kg	8.4	8.4	8.4
	Net Dimensions (W×H×D)	mm	950 x 48 x 950	950 x 48 x 950	950 x 48 x 950
	Shipping Dimensions (W×H×D)	mm	1,010 x 117 x 1,000	1,010 x 117 x 1,000	1,010 x 117 x 1,000
Drain Pump	Drain Pump	-	INCLUDED	INCLUDED	INCLUDED
	Max. lifting Height / Displacement	mm / Liter/h	750 / 24	750 / 24	750 / 24

### NOTE

- Specification may be subject to change without prior notice.
  - 1) Capacities are based on (Equivalent refrigerant piping 7.5m, Level differences 0m);
    - Cooling : Indoor temperature 27°C DB, 19°C WB / Outdoor temperature 35°C DB, 24°C WB
    - Heating : Indoor temperature 20°C DB, 15°C WB / Outdoor temperature 7°C DB, 6°C WB
  - 2) Sound level was acquired in an anechoic room. Thus actual noise level may be different depending on the installation conditions.
  - 3) These products contain R32 (GWP=675) which is fluorinated greenhouse gas.
  - 4) Select wire size based on the value of MCA

## 2. Summary Table

### WindFree™ 4Way Cassette

#### Performance Characteristics

Model Code	Net Weight (kg)	Fan Speed	Nominal Capacity (kW)			Airflow (CMM)	Sound Pressure (dBA)	Sound Power (dBA)
			Cooling	Sensible	Heating			
AM028DN4DKG/EU	15.0	High	2.8	2.0	3.2	14.4	30	46
		Mid	2.4	1.7	3.0	13.4	28	-
		Low	2.2	1.6	2.8	12.4	27	-
		W/Free	1.3	1.0	-	7.3	27	-
AM036DN4DKG/EU	15.0	High	3.6	2.5	4.0	15.4	31	47
		Mid	3.1	2.2	3.7	14.4	30	-
		Low	2.7	1.9	3.4	13.4	28	-
		W/Free	1.7	1.2	-	7.7	28	-
AM045DN4DKG/EU	15.0	High	4.5	3.1	5.0	16.3	33	49
		Mid	4.2	2.9	4.8	15.4	31	-
		Low	4.0	2.7	4.6	14.4	29	-
		W/Free	2.2	1.8	-	8.0	29	-
AM056DN4DKG/EU	16.5	High	5.6	3.9	6.3	16.4	35	51
		Mid	5.3	3.7	6.1	14.6	33	-
		Low	4.9	3.4	5.9	12.8	29	-
		W/Free	2.6	2.2	-	8.0	29	-
AM071DN4DKG/EU	16.5	High	7.1	5.0	8.0	18.2	37	53
		Mid	6.6	4.6	7.6	15.4	34	-
		Low	6.2	4.3	7.4	12.8	30	-
		W/Free	3.3	2.7	-	8.0	30	-
AM090DN4DKG/EU	18.0	High	9.0	6.3	10.0	24.4	39	55
		Mid	8.4	5.8	9.6	19.9	35	-
		Low	7.8	5.4	9.2	15.5	30	-
		W/Free	4.1	3.4	-	10.0	30	-
AM112DN4DKG/EU	19.0	High	11.2	7.9	12.5	26.6	41	59
		Mid	10.5	7.4	12.0	21.0	36	-
		Low	9.7	6.7	11.5	15.5	30	-
		W/Free	5.0	4.2	-	10.0	30	-
AM128DN4DKG/EU	21.5	High	12.8	9.1	13.8	35.4	42	58
		Mid	12.0	8.5	13.3	29.2	37	-
		Low	10.8	7.6	12.5	24.3	35	-
		W/Free	5.8	4.8	-	11.2	35	-
AM140DN4DKG/EU	22.5	High	14.0	9.6	16.0	37.9	44	60
		Mid	13.2	9.0	15.5	31.7	39	-
		Low	12.4	8.4	14.9	25.5	35	-
		W/Free	6.2	5.2	-	11.4	35	-

#### NOTE

- Sound data is based on cooling operation.

## 2. Summary Table

### WindFree™ 4Way Cassette

#### Performance Characteristics

Model Code	Net Weight (kg)	Fan Speed	Nominal Capacity (kW)			Airflow (CMM)	Sound Pressure (dBA)	Sound Power (dBA)
			Cooling	Sensible	Heating			
AM022DN4FKG/EU	18.0	High	2.2	2.1	2.5	13.0	32	48
		Mid	2.1	2.0	2.4	12.0	30	-
		Low	1.9	1.8	2.3	11.0	29	-
		W/Free	1.1	1.1	-	6.5	29	-
AM028DN4FKG/EU	18.0	High	2.8	2.7	3.2	14.0	33	49
		Mid	2.6	2.5	3.1	13.0	31	-
		Low	2.4	2.3	3.0	12.0	30	-
		W/Free	1.4	1.4	-	7.0	30	-
AM036DN4FKG/EU	18.0	High	3.6	3.4	4.0	16.0	34	50
		Mid	3.4	3.2	3.9	15.0	33	-
		Low	3.2	3.0	3.7	14.0	31	-
		W/Free	1.9	1.9	-	8.5	31	-
AM045DN4FKG/EU	18.0	High	4.5	4.2	5.0	18.0	34	50
		Mid	4.1	3.8	4.7	16.0	32	-
		Low	3.6	3.4	4.4	14.0	30	-
		W/Free	2.1	2.1	-	8.5	30	-
AM056DN4FKG/EU	21.5	High	5.6	5.3	6.3	24.0	35	51
		Mid	5.0	4.7	5.9	21.0	33	-
		Low	4.6	4.4	5.6	19.0	29	-
		W/Free	2.8	2.8	-	12.0	29	-
AM071DN4FKG/EU	22.5	High	7.1	6.7	8.0	31.0	39	55
		Mid	6.1	5.8	7.3	26.0	36	-
		Low	5.0	4.7	6.6	21.0	32	-
		W/Free	2.8	2.8	-	13.0	32	-

#### NOTE

- Sound data is based on cooling operation.

#### Electric Characteristics

Indoor Unit	Power Supply (Ø, #, V, Hz)	Power Input (W)	Current Input (A)	MCA (A)	MFA (A)	FLA (A)
AM028DN4DKG/EU	1,2,220~240,50/60	24.0	0.25	0.33	15	0.26
AM036DN4DKG/EU	1,2,220~240,50/60	26.0	0.27	0.36	15	0.28
AM045DN4DKG/EU	1,2,220~240,50/60	28.0	0.30	0.40	15	0.31
AM056DN4DKG/EU	1,2,220~240,50/60	32.0	0.32	0.43	15	0.33
AM071DN4DKG/EU	1,2,220~240,50/60	34.0	0.35	0.47	15	0.37
AM090DN4DKG/EU	1,2,220~240,50/60	55.0	0.45	0.60	15	0.47
AM112DN4DKG/EU	1,2,220~240,50/60	78.0	0.60	0.80	15	0.63
AM128DN4DKG/EU	1,2,220~240,50/60	95.0	0.75	1.00	15	0.77
AM140DN4DKG/EU	1,2,220~240,50/60	115.0	0.85	1.13	15	0.88
AM022DN4FKG/EU	1,2,220~240,50/60	17.0	0.14	0.29	15	0.23
AM028DN4FKG/EU	1,2,220~240,50/60	20.0	0.17	0.33	15	0.26
AM036DN4FKG/EU	1,2,220~240,50/60	27.0	0.23	0.41	15	0.33
AM045DN4FKG/EU	1,2,220~240,50/60	35.0	0.29	0.49	15	0.39
AM056DN4FKG/EU	1,2,220~240,50/60	49.0	0.38	0.57	15	0.46
AM071DN4FKG/EU	1,2,220~240,50/60	75.0	0.58	0.56	15	0.69

#### NOTE

- MCA : Minimum circuit amperes
- MFA : Maximum fuse amperes
- Select wire size based on the value of MCA

# 3. Capacity Table

## WindFree™ 4Way Cassette

### Cooling

TC : Total Capacity, SHC : Sensible Heat Capacity

Combination, % (Capacity index)	Outdoor temperature (°C, DB)	Indoor temperature (°C)													
		20 (DB)		23 (DB)		26 (DB)		27 (DB)		28 (DB)		30 (DB)		32 (DB)	
		14 (WB)		16 (WB)		18 (WB)		19 (WB)		20 (WB)		22 (WB)		24 (WB)	
		TC	SHC	TC	SHC	TC	SHC	TC	SHC	TC	SHC	TC	SHC	TC	SHC
AM028DN4DKG/EU	35	1.9	1.7	2.3	1.8	2.6	2.0	2.8	2.0	2.9	2.0	3.1	2.0	3.3	1.8
AM036DN4DKG/EU	35	2.5	2.1	2.9	2.3	3.4	2.4	3.6	2.5	3.7	2.5	4.0	2.5	4.2	2.4
AM045DN4DKG/EU	35	3.1	2.7	3.7	2.8	4.2	3.0	4.5	3.1	4.7	3.1	5.0	3.1	5.3	2.8
AM056DN4DKG/EU	35	3.9	3.2	4.6	3.5	5.3	3.9	5.6	3.9	5.8	3.9	6.2	3.8	6.6	3.6
AM071DN4DKG/EU	35	4.9	4.0	5.8	4.5	6.7	4.8	7.1	5.0	7.4	5.0	7.9	5.0	8.4	4.8
AM090DN4DKG/EU	35	6.2	5.2	7.3	5.7	8.4	6.3	9.0	6.3	9.3	6.3	10.0	6.2	10.6	6.1
AM112DN4DKG/EU	35	7.7	6.3	9.1	7.0	10.5	7.8	11.2	7.9	11.6	7.9	12.4	7.9	13.2	7.7
AM128DN4DKG/EU	35	8.8	7.3	10.4	8.1	12.0	9.0	12.8	9.1	13.3	9.1	14.2	9.0	15.1	8.8
AM140DN4DKG/EU	35	9.7	7.7	11.4	8.5	13.1	9.4	14.0	9.6	14.5	9.6	15.5	9.5	16.5	9.4
AM022DN4FKG/EU	35	1.1	1.1	1.5	1.5	2.0	2.0	2.2	2.1	2.3	2.1	2.6	2.3	2.9	2.4
AM028DN4FKG/EU	35	1.4	1.4	2.0	2.0	2.5	2.5	2.8	2.7	3.0	2.8	3.3	2.9	3.6	3.0
AM036DN4FKG/EU	35	1.8	1.8	2.5	2.5	3.2	3.1	3.6	3.4	3.8	3.5	4.2	3.6	4.7	3.8
AM045DN4FKG/EU	35	2.3	2.3	3.2	3.2	4.1	3.9	4.5	4.2	4.8	4.3	5.3	4.5	5.9	4.7
AM056DN4FKG/EU	35	2.8	2.8	3.9	3.9	5.0	4.9	5.6	5.3	5.9	5.4	6.6	5.7	7.3	5.9
AM071DN4FKG/EU	35	3.6	3.6	5.0	5.0	6.4	6.2	7.1	6.7	7.5	6.9	8.4	7.2	9.2	7.4

### Heating

TC : Total Capacity (kW)

Combination, % (Capacity index)	Outdoor temperature (°C)		Indoor temperature (°C, WB)						
			14.0	16.0	18.0	20.0	22.0	24.0	27.0
	DB	WB	TC	TC	TC	TC	TC	TC	TC
			kW	kW	kW	kW	kW	kW	kW
AM028DN4DKG/EU	7	6.0	3.4	3.3	3.2	3.2	3.0	2.7	2.3
AM036DN4DKG/EU	7	6.0	4.2	4.1	4.1	4.0	3.7	3.4	3.0
AM045DN4DKG/EU	7	6.0	5.3	5.1	5.1	5.0	4.6	4.2	3.6
AM056DN4DKG/EU	7	6.0	6.7	6.5	6.4	6.3	5.8	5.3	4.6
AM071DN4DKG/EU	7	6.0	8.5	8.2	8.1	8.0	7.4	6.8	5.9
AM090DN4DKG/EU	7	6.0	10.6	10.3	10.1	10.0	9.2	8.4	7.3
AM112DN4DKG/EU	7	6.0	13.2	12.9	12.7	12.5	11.5	10.6	9.2
AM128DN4DKG/EU	7	6.0	14.6	14.2	14.0	13.8	12.7	11.7	10.2
AM140DN4DKG/EU	7	6.0	16.9	16.5	16.2	16.0	14.8	13.5	11.7
AM022DN4FKG/EU	7	6.0	3.0	2.8	2.7	2.5	2.3	2.0	1.6
AM028DN4FKG/EU	7	6.0	3.8	3.6	3.4	3.2	2.9	2.6	2.1
AM036DN4FKG/EU	7	6.0	4.7	4.5	4.2	4.0	3.6	3.2	2.6
AM045DN4FKG/EU	7	6.0	5.9	5.6	5.3	5.0	4.5	4.0	3.3
AM056DN4FKG/EU	7	6.0	7.4	7.1	6.7	6.3	5.7	5.0	4.1
AM071DN4FKG/EU	7	6.0	9.4	9.0	8.5	8.0	7.2	6.4	5.2

### NOTE

- The performance table shows the average value of each conditions.

# 4. Dimensional Drawing

## WindFree™ 4Way Cassette

AM028DN4DKG/EU, AM036DN4DKG/EU, AM045DN4DKG/EU, AM056DN4DKG/EU, AM071DN4DKG/EU

Units : mm [inches]

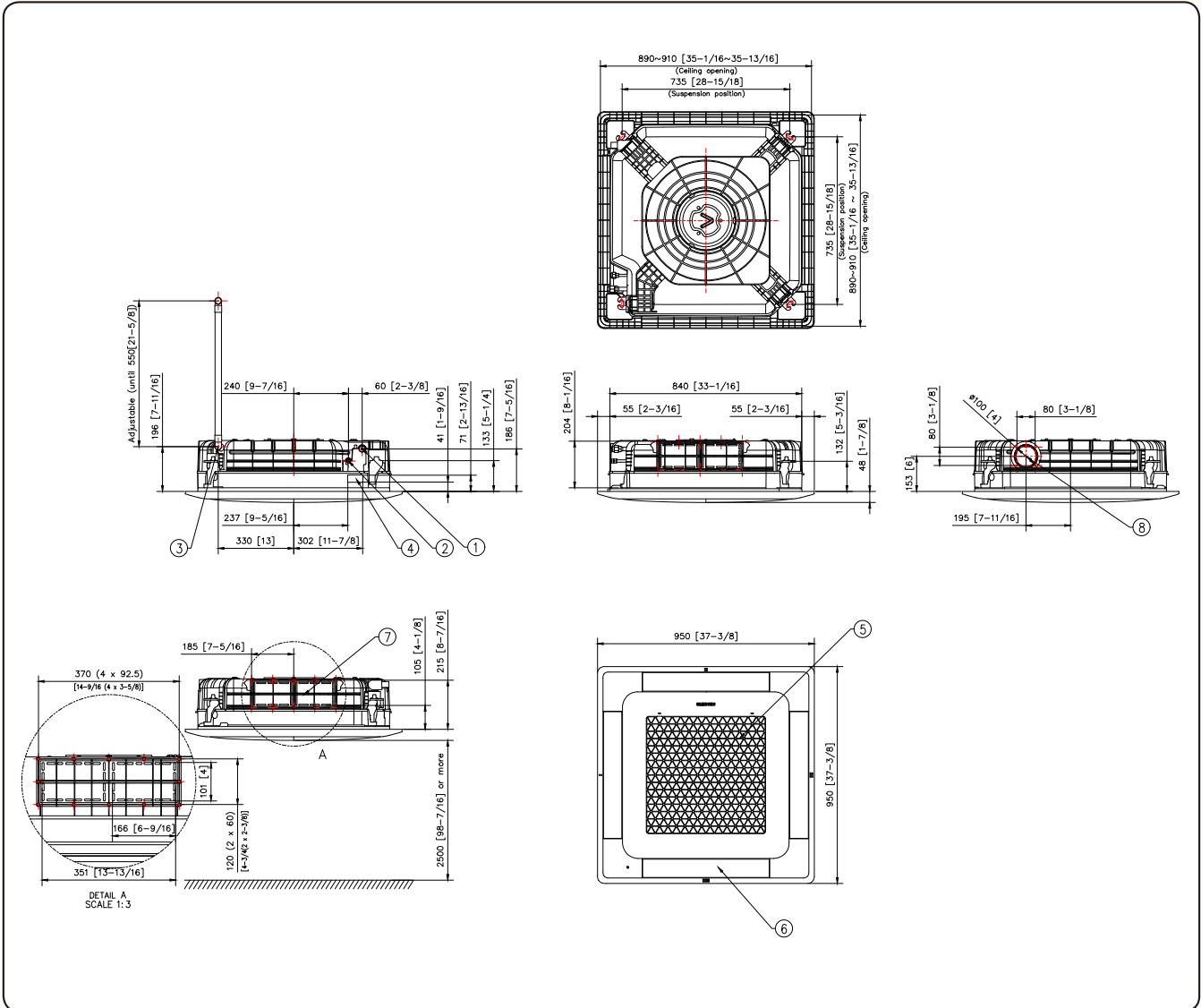

No.	Name	Description	
		AM028DN4DKG/EU, AM036DN4DKG/EU, AM045DN4DKG/EU, AM056DN4DKG/EU	AM071DN4DKG/EU
1	Gas pipe connection	Φ12.7[1/2]	Φ15.88[5/8]
2	Liquid pipe connection	Φ6.35[1/4]	
3	Drain pipe connection	VP-25(OD32, ID25)	
4	Power supply & Communication wiring conduit	-	
5	Air Inlet Grille	-	
6	Air Outlet Louver	-	
7	Sub - duct	* The sub duct is not applicabel to the WindFree™ panel	
8	Fresh air intake	Φ10[4] , Use M4 Screw	

### NOTE

- As for suspension bolt, please use M8 ~ M10. (Procured at local site)

# 4. Dimensional Drawing

## WindFree™ 4Way Cassette

AM090DN4DKG/EU, AM112DN4DKG/EU, AM022DN4FKG/EU, AM028DN4FKG/EU  
 AM036DN4FKG/EU, AM045DN4FKG/EU

Units : mm [inches]

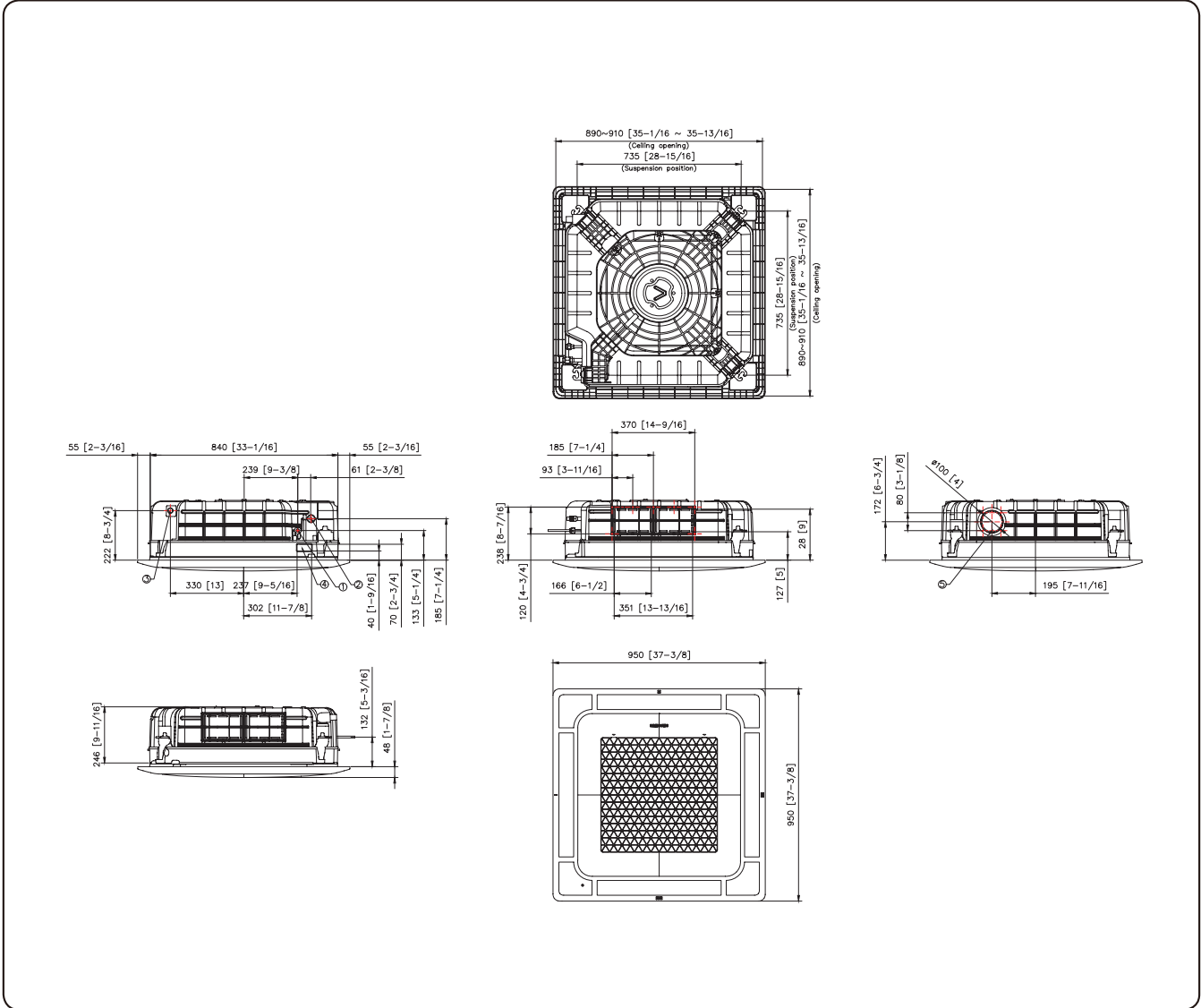

No.	Name	Description	
		AM022DN4FKG/EU, AM028DN4FKG/EU, AM036DN4FKG/EU, AM045DN4FKG/EU	AM090DN4DKG/EU, AM112DN4DKG/EU
1	Liquid pipe connection	Φ6.35[1/4]	Φ9.52[3/8]
2	Gas pipe connection	Φ12.7[1/2]	Φ15.88[5/8]
3	Drain pipe connection	VP-25(OD32, ID25)	
4	Power supply & Communication wiring conduit	-	
5	Fresh air intake	Φ10[4] , Use M4 Screw	

### NOTE

- As for suspension bolt, please use M8 ~ M10. (Procured at local site)

# 4. Dimensional Drawing

## WindFree™ 4Way Cassette

AM128DN4DKG/EU, AM140DN4DKG/EU, AM056DN4FKG/EU, AM071DN4FKG/EU

Units : mm [inches]

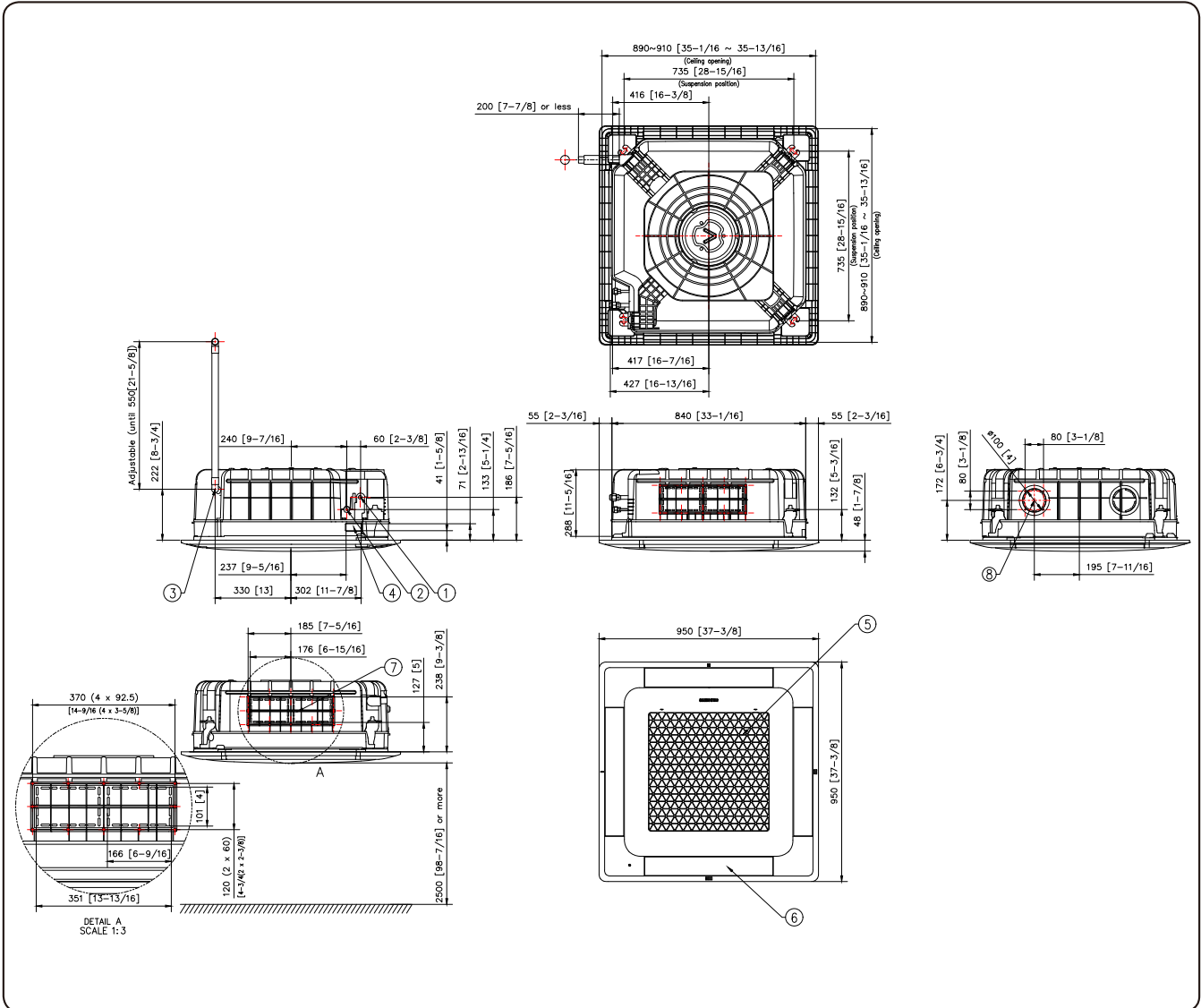

No.	Name	Description	
		AM056DN4FKG/EU	AM071DN4FKG/EU, AM128DN4DKG/EU AM140DN4DKG/EU
1	Gas pipe connection	Φ6.35[1/4]	Φ15.88[5/8]
2	Liquid pipe connection	Φ12.7[1/2]	Φ9.52[3/8]
3	Drain pipe connection	VP-25(OD32, ID25)	
4	Power supply & Communication wiring conduit	-	
5	Air Inlet Grille	-	
6	Air Outlet Louver	-	
7	Sub - duct	* The sub duct is not applicabel to the WindFree™ panel	
8	Fresh air intake	Φ10[4] , Use M4 Screw	

### NOTE

- As for suspension bolt, please use M8 ~ M10. (Procured at local site)

# 5. Center of Gravity

## WindFree™ 4Way Cassette

Units : mm [inches]

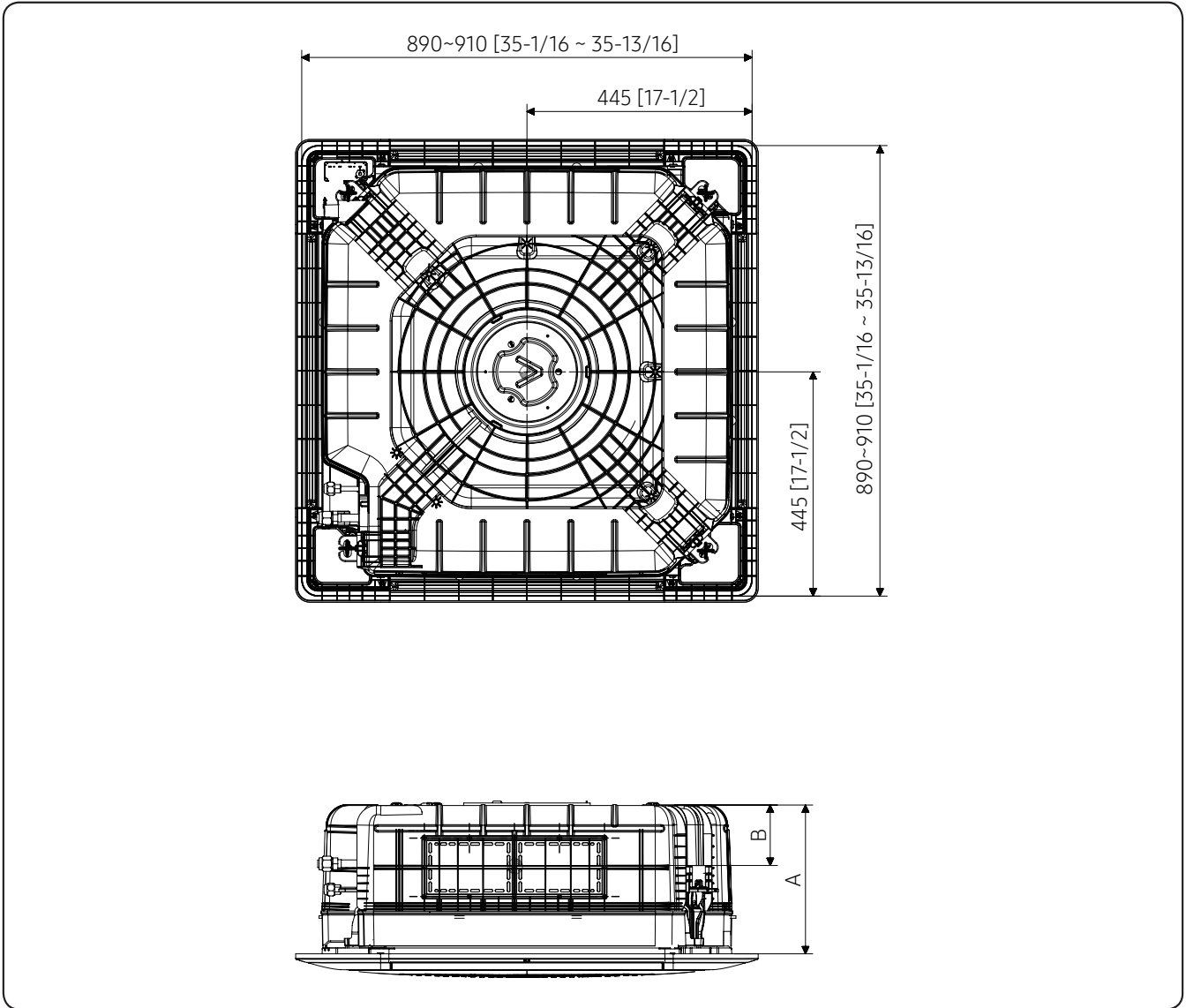

	A	B
AM028DN4DKG/EU, AM036DN4DKG/EU AM045DN4DKG/EU, AM056DN4DKG/EU AM071DN4DKG/EU	221 [8-11/16]	70 [2-3/4]
AM090DN4DKG/EU, AM112DN4DKG/EU AM022DN4FKG/EU, AM028DN4FKG/EU AM036DN4FKG/EU, AM045DN4FKG/EU	263 [10-7/20]	100[4]
AM128DN4DKG/EU, AM140DN4DKG/EU AM056DN4FKG/EU, AM071DN4FKG/EU	305 [12]	130 [5-1/8]

# 6. Electrical Wiring Diagram

## WindFree™ 4Way Cassette

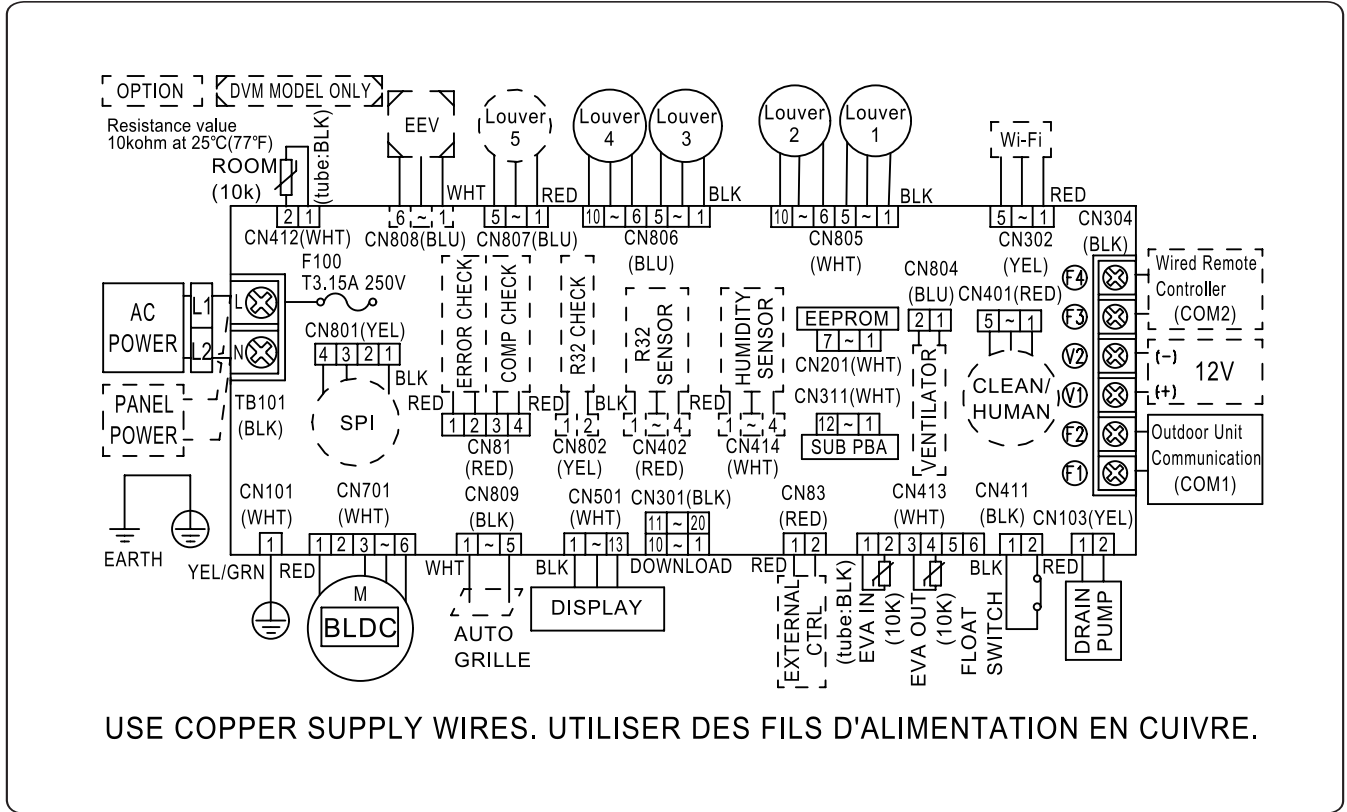

F100	FUSE	EEV	Electronic Expansion Valve	ROOM(10K)	Thermistor ROOM OUT(10K)
M-BLDC	BLDC Motor	EXT_CONTROL	EXTERNAL_CONTROL	EVA-IN(10K)	Thermistor EVA IN(10K)
				EVA-OUT(10K)	Thermistor EVA OUT(10K)

### NOTE

- This wiring diagram applies only to the Indoor unit.
- Symbols show as follow :  
blk: black, red: red, blu: blue, wht: white, yel: yellow, brn: brown, sky: skyblue: grn: green
- For connection wiring indoor-outdoor transmission F1-F2, indoor-wired remote controller transmission F3-F4.
- Protective earth(screw), : connector, : The wire quantity

# 7. Sound Data

## WindFree™ 4Way Cassette

### Sound Pressure level

Unit: dB(A)

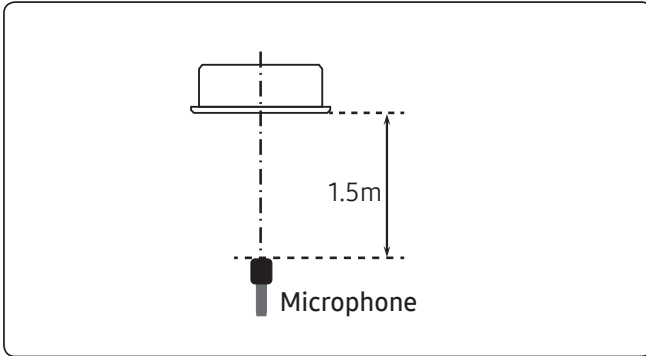

Model	High	MID	LOW	WindFree
AM028DN4DKG/EU	30	28	27	27
AM036DN4DKG/EU	31	30	28	28
AM045DN4DKG/EU	33	31	29	29
AM056DN4DKG/EU	35	33	29	29

- NR Curve

1) AM028DN4DKG/EU

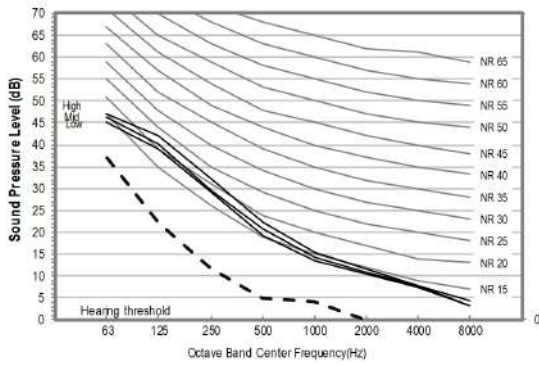

2) AM036DN4DKG/EU

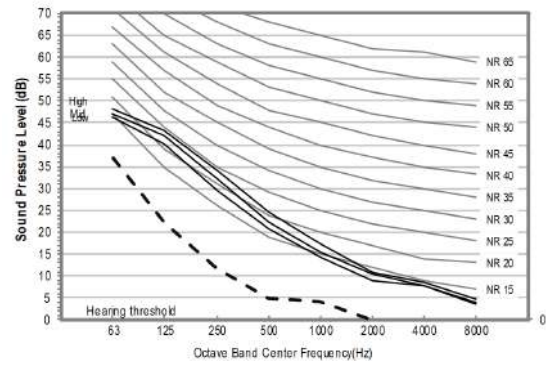

3) AM045DN4DKG/EU

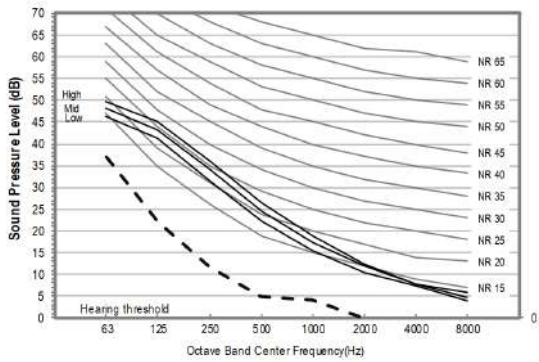

4) AM056DN4DKG/EU

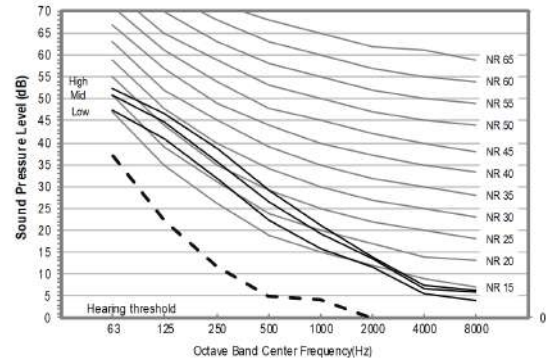

### NOTE

- Specifications may be subject to change without prior notice.
  - Sound pressure level is obtained in an anechoic room.
  - Sound pressure level is a relative value, depending on the distance and acoustic environment.
  - Sound pressure level may differ depending on operation condition.
  - dBA = A weighted sound pressure level
  - Reference acoustic pressure 0 dB = 20μPa

# 7. Sound Data

## WindFree™ 4Way Cassette

### Sound Pressure level

Unit: dB(A)

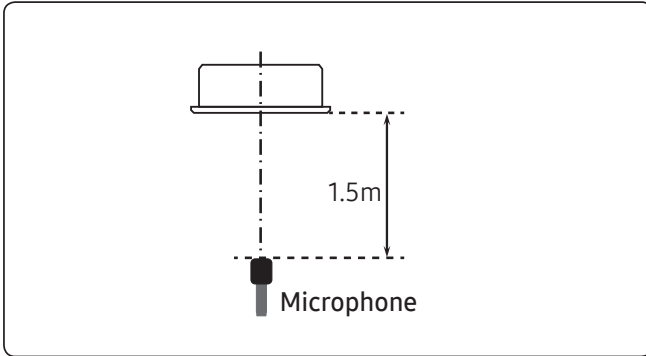

Model	High	MID	LOW	WindFree
AM071DN4DKG/EU	37	34	30	30
AM090DN4DKG/EU	39	35	30	30
AM112DN4DKG/EU	41	36	30	30
AM128DN4DKG/EU	42	37	35	35

- NR Curve

1) AM071DN4DKG/EU

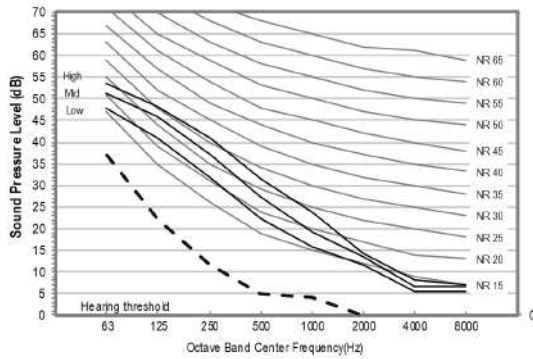

2) AM090DN4DKG/EU

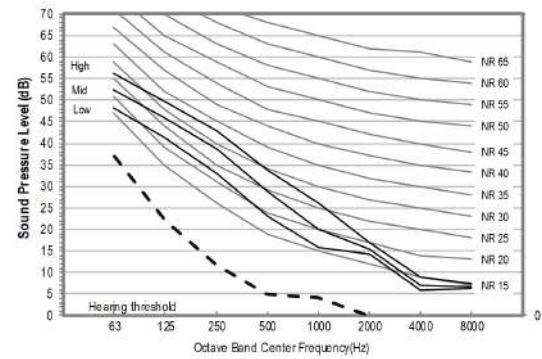

3) AM112DN4DKG/EU

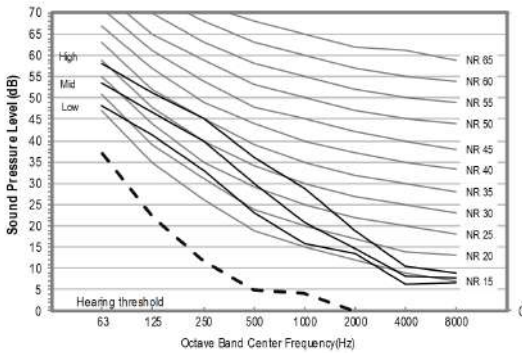

4) AM128DN4DKG/EU

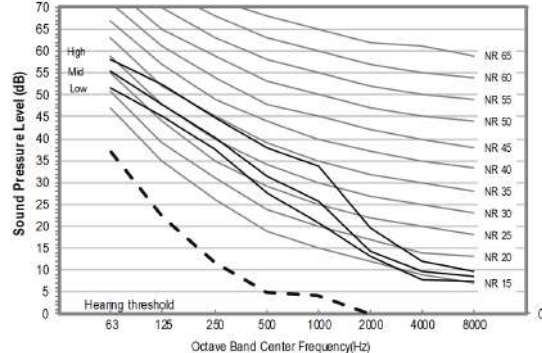

### NOTE

- Specifications may be subject to change without prior notice.
  - Sound pressure level is obtained in an anechoic room.
  - Sound pressure level is a relative value, depending on the distance and acoustic environment.
  - Sound pressure level may differ depending on operation condition.
  - dB(A) = A weighted sound pressure level
  - Reference acoustic pressure 0 dB = 20μPa

# 7. Sound Data

## WindFree™ 4Way Cassette

### Sound Pressure level

Unit: dB(A)

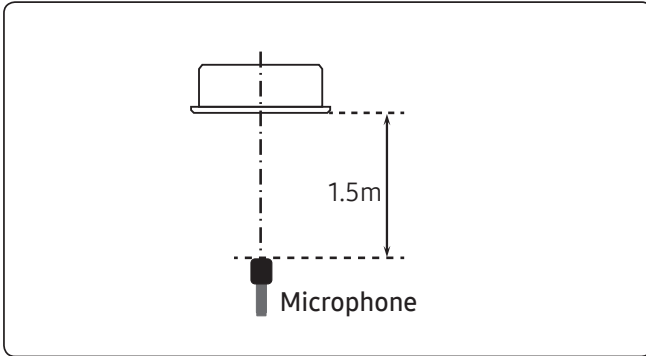

Model	High	MID	LOW	WindFree
AM140DN4DKG/EU	44	39	35	35
AM022DN4FKG/EU	32	30	29	29
AM028DN4FKG/EU	33	31	30	30
AM036DN4FKG/EU	34	33	31	31

- NR Curve

1) AM140DN4DKG/EU

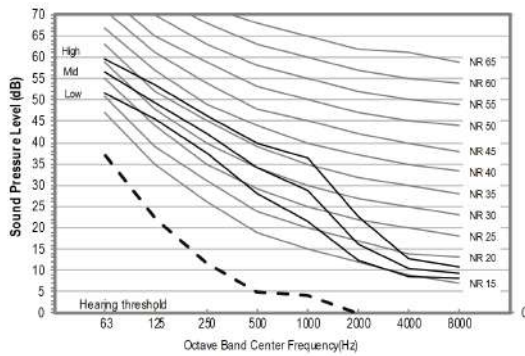

2) AM022DN4FKG/EU

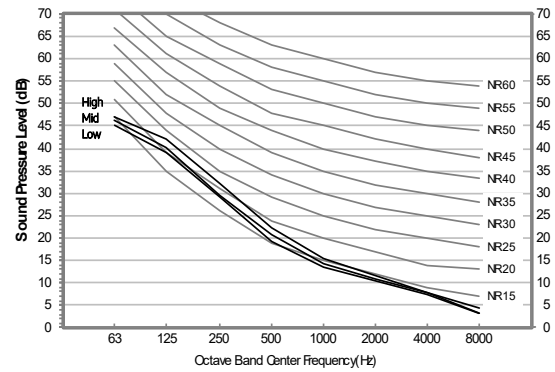

3) AM028DN4FKG/EU

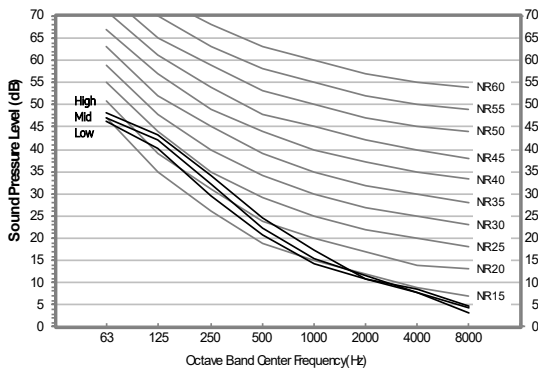

4) AM036DN4FKG/EU

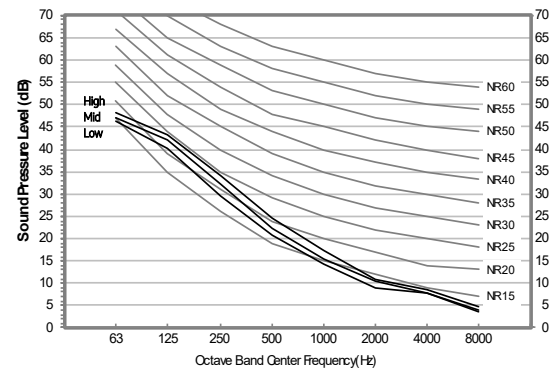

### NOTE

- Specifications may be subject to change without prior notice.
  - Sound pressure level is obtained in an anechoic room.
  - Sound pressure level is a relative value, depending on the distance and acoustic environment.
  - Sound pressure level may differ depending on operation condition.
  - dB(A) = A weighted sound pressure level
  - Reference acoustic pressure 0 dB = 20μPa

# 7. Sound Data

## WindFree™ 4Way Cassette

### Sound Pressure level

Unit: dB(A)

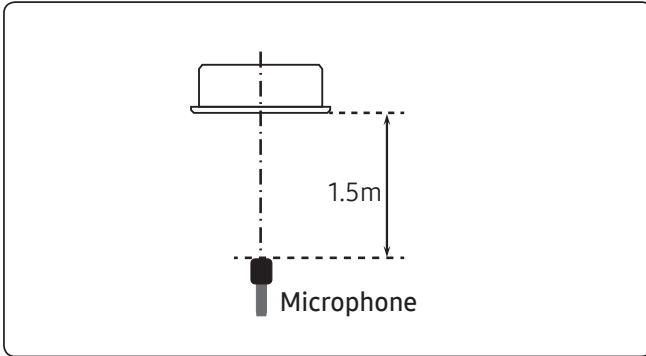

Model	High	MID	LOW	WindFree
AM045DN4FKG/EU	34	32	30	30
AM056DN4FKG/EU	35	33	29	29
AM071DN4FKG/EU	39	36	32	32

• NR Curve

1) AM045DN4FKG/EU

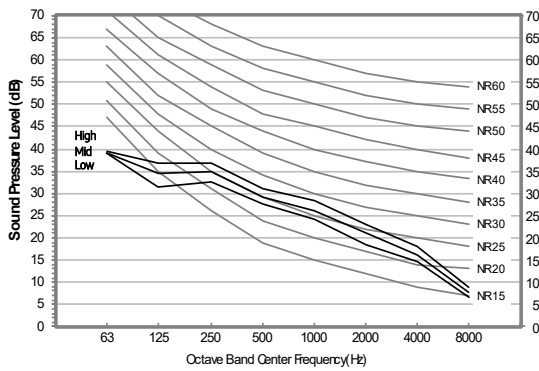

2) AM056DN4FKG/EU

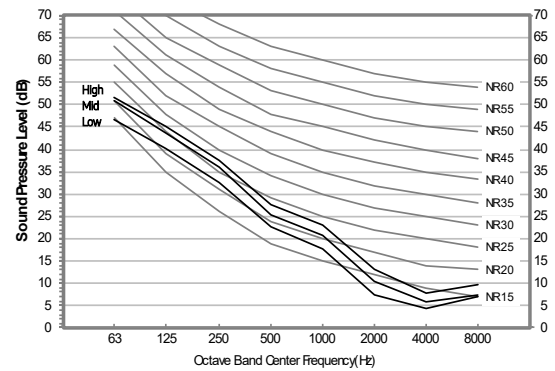

3) AM071DN4FKG/EU

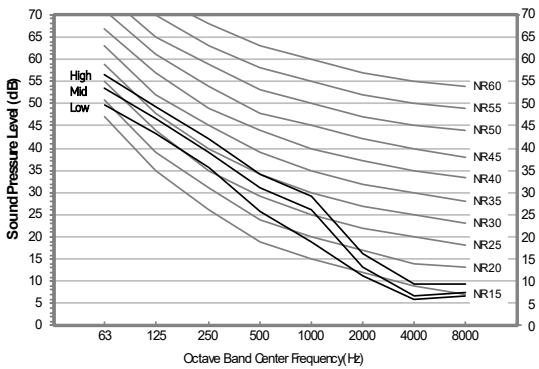

**NOTE**

- Specifications may be subject to change without prior notice.
  - Sound pressure level is obtained in an anechoic room.
  - Sound pressure level is a relative value, depending on the distance and acoustic environment.
  - Sound pressure level may differ depending on operation condition.
  - dBA = A weighted sound pressure level
  - Reference acoustic pressure 0 dB = 20μPa

# 7. Sound Data

## WindFree™ 4Way Cassette

### Sound Power level

#### NOTE

- Specifications may be subject to change without prior notice
  - Sound power level is an absolute value that a sound source generates.
  - dB(A) = A-weighted sound power level.
  - Reference power : 1pW.
  - Measured according to ISO 3741.

Unit: dB(A)

Model	Power
AM028DN4DKG/EU	46
AM036DN4DKG/EU	47
AM045DN4DKG/EU	49
AM056DN4DKG/EU	51

#### NR Curve

1) AM028DN4DKG/EU

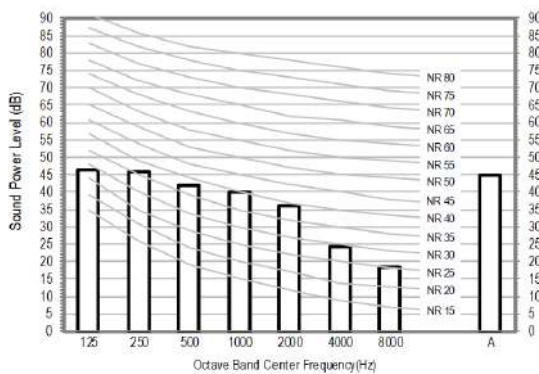

2) AM036DN4DKG/EU

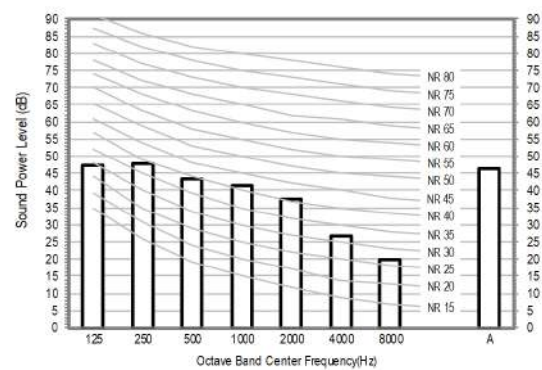

3) AM045DN4DKG/EU

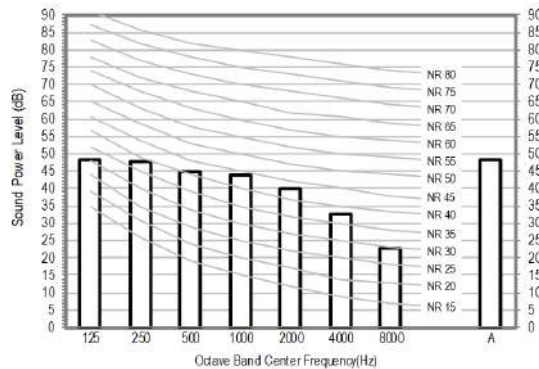

4) AM056DN4DKG/EU

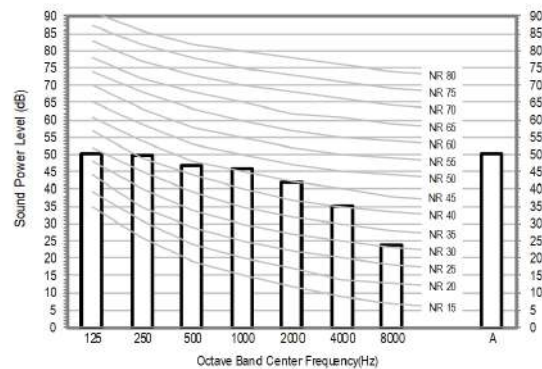

# 7. Sound Data

## WindFree™ 4Way Cassette

### Sound Power level

#### NOTE

- Specifications may be subject to change without prior notice
  - Sound power level is an absolute value that a sound source generates.
  - dBA = A-weighted sound power level.
  - Reference power : 1pW.
  - Measured according to ISO 3741.

Unit: dB(A)

Model	Power
AM071DN4DKG/EU	53
AM090DN4DKG/EU	55
AM112DN4DKG/EU	59
AM128DN4DKG/EU	58

#### NR Curve

1) AM071DN4DKG/EU

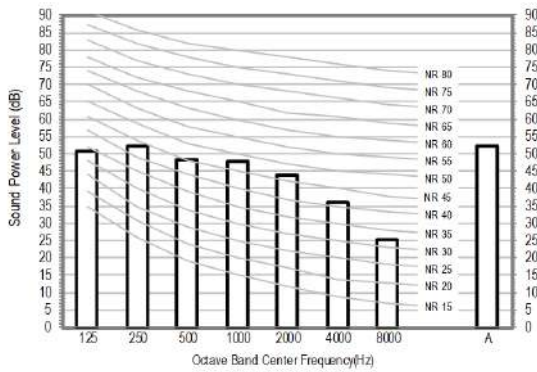

2) AM090DN4DKG/EU

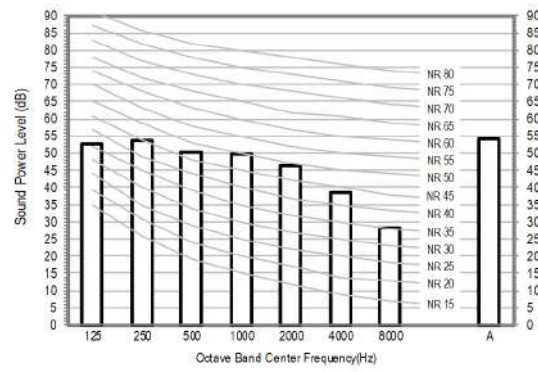

3) AM112DN4DKG/EU

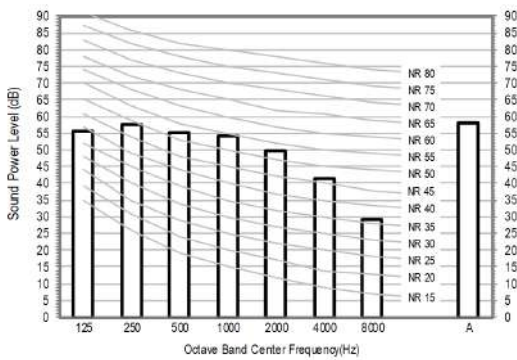

4) AM128DN4DKG/EU

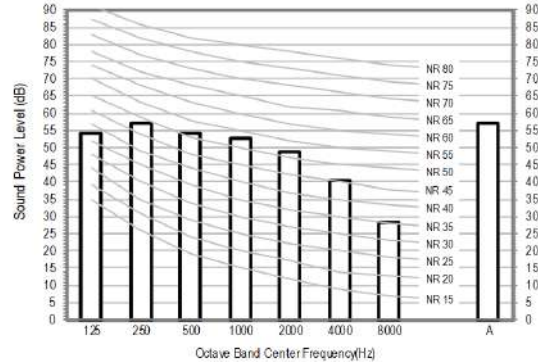

# 7. Sound Data

## WindFree™ 4Way Cassette

### Sound Power level

#### NOTE

- Specifications may be subject to change without prior notice
  - Sound power level is an absolute value that a sound source generates.
  - dBA = A-weighted sound power level.
  - Reference power : 1pW.
  - Measured according to ISO 3741.

Unit: dB(A)

Model	Power
AM140DN4DKG/EU	60
AM022DN4FKG/EU	48
AM028DN4FKG/EU	49
AM036DN4FKG/EU	50

#### NR Curve

##### 1) AM140DN4DKG/EU

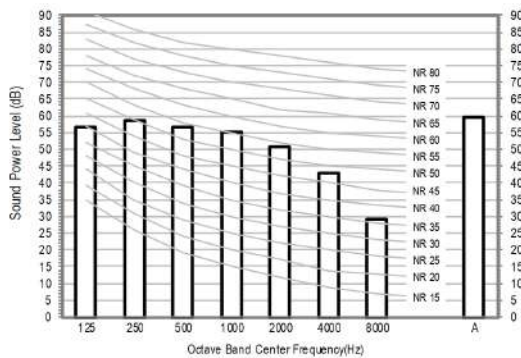

##### 2) AM022DN4FKG/EU

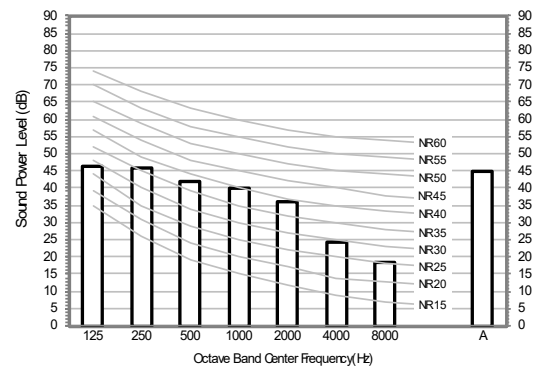

##### 3) AM028DN4FKG/EU

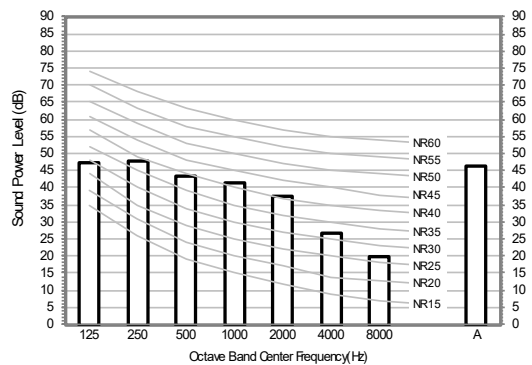

##### 4) AM036DN4FKG/EU

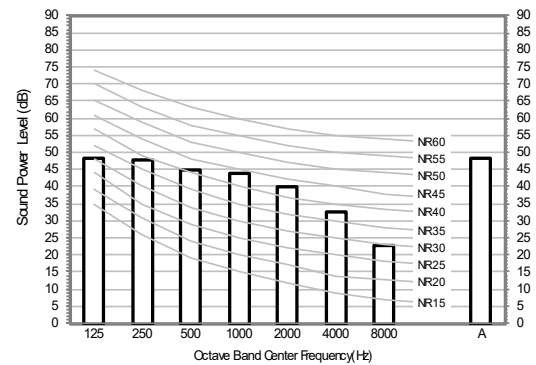

# 7. Sound Data

## WindFree™ 4Way Cassette

### Sound Power level

#### NOTE

- Specifications may be subject to change without prior notice
  - Sound power level is an absolute value that a sound source generates.
  - dB(A) = A-weighted sound power level.
  - Reference power : 1pW.
  - Measured according to ISO 3741.

Unit: dB(A)

Model	Power
AM045DN4FKG/EU	50
AM056DN4FKG/EU	51
AM071DN4FKG/EU	55

#### NR Curve

1) AM045DN4FKG/EU

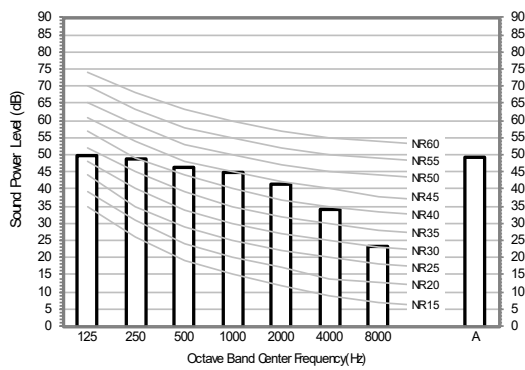

2) AM056DN4FKG/EU

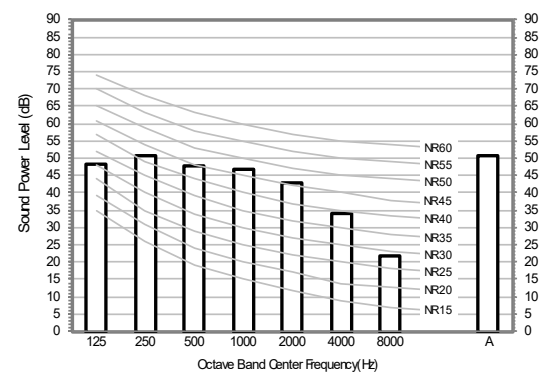

3) AM071DN4FKG/EU

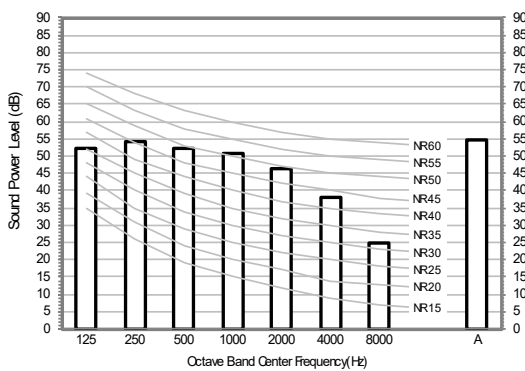

# 8. Temperature and air flow distribution

## WindFree™ 4Way Cassette

### AM028DN4DKG/EU

- Cooling Air Velocity distribution  
(Discharge angle : 45 degree)

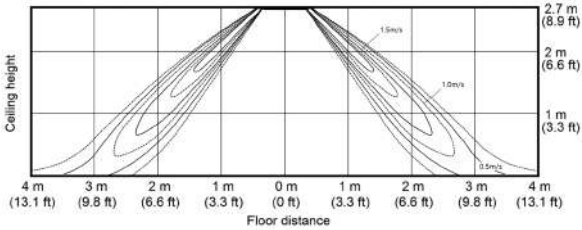

- Cooling temperature distribution  
(Discharge angle : 45 degree)

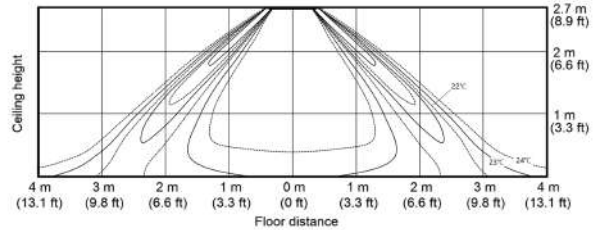

- Heating Air Velocity distribution  
(Discharge angle : 52 degree)

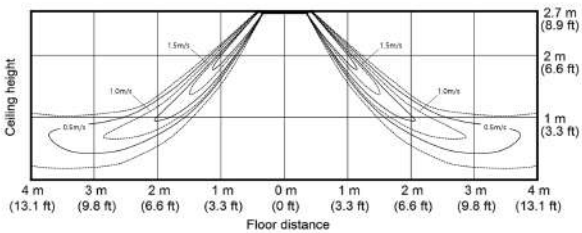

- Heating temperature distribution  
(Discharge angle : 52 degree)

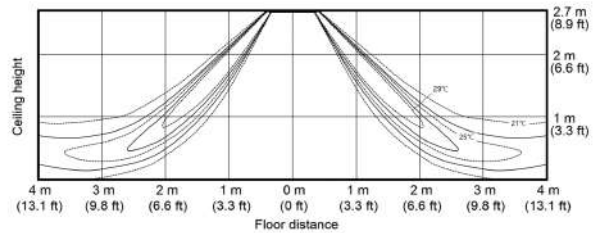

### AM036DN4DKG/EU

- Cooling Air Velocity distribution  
(Discharge angle : 45 degree)

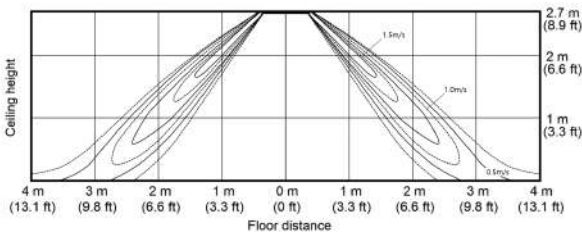

- Cooling temperature distribution  
(Discharge angle : 45 degree)

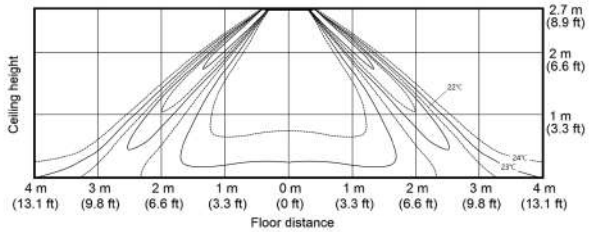

- Heating Air Velocity distribution  
(Discharge angle : 52 degree)

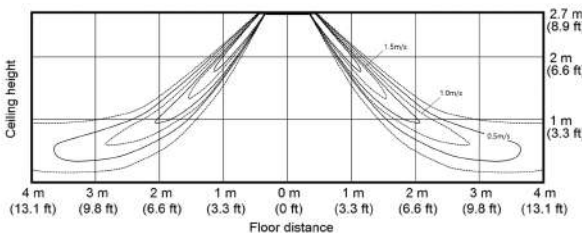

- Heating temperature distribution  
(Discharge angle : 52 degree)

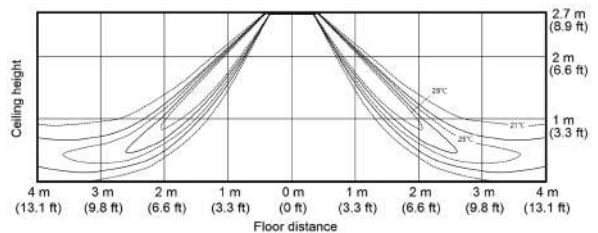

# 8. Temperature and air flow distribution

## WindFree™ 4Way Cassette

### AM045DN4DKG/EU

- Cooling Air Velocity distribution  
(Discharge angle : 45 degree)

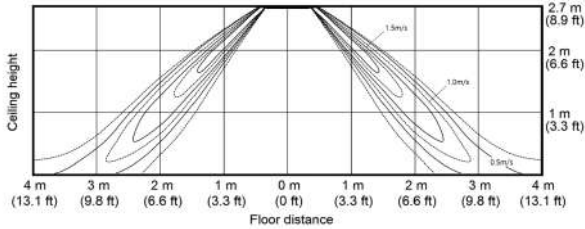

- Cooling temperature distribution  
(Discharge angle : 45 degree)

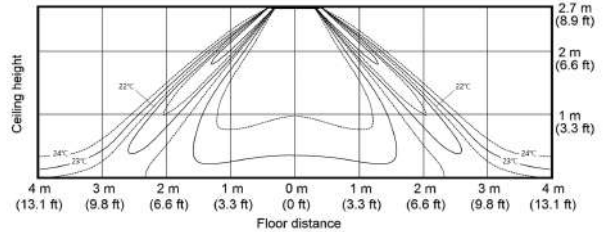

- Heating Air Velocity distribution  
(Discharge angle : 52 degree)

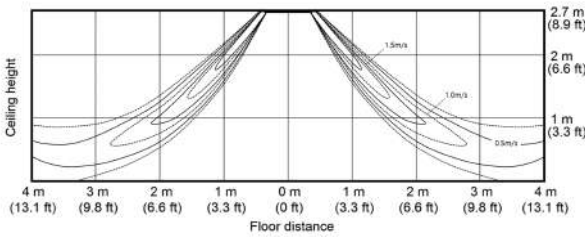

- Heating temperature distribution  
(Discharge angle : 52 degree)

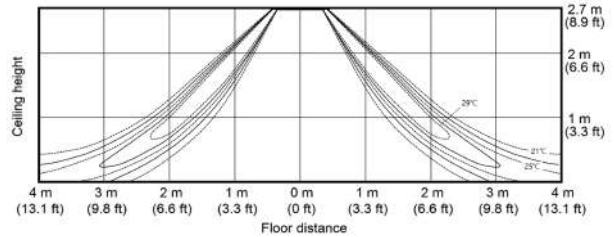

### AM056DN4DKG/EU

- Cooling Air Velocity distribution  
(Discharge angle : 45 degree)

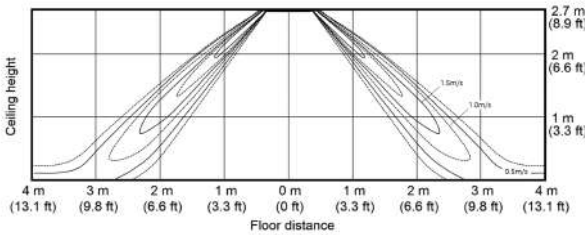

- Cooling temperature distribution  
(Discharge angle : 45 degree)

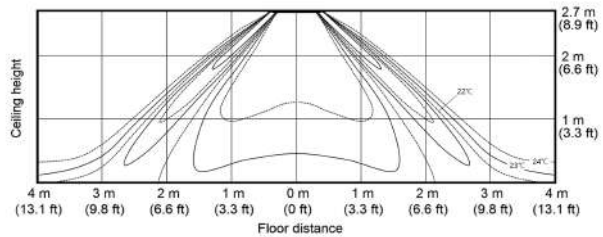

- Heating Air Velocity distribution  
(Discharge angle : 52 degree)

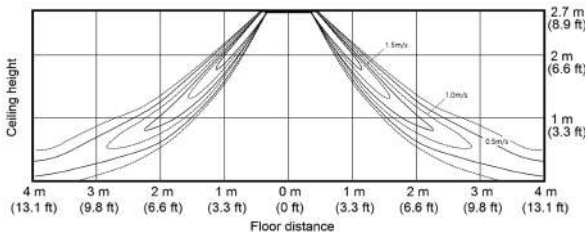

- Heating temperature distribution  
(Discharge angle : 52 degree)

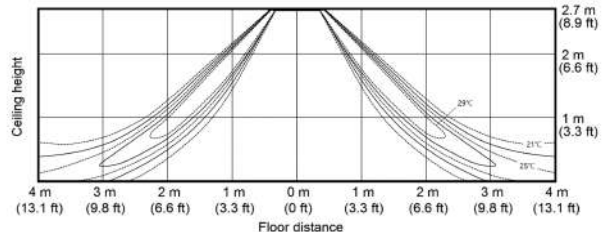

# 8. Temperature and air flow distribution

## WindFree™ 4Way Cassette

### AM071DN4DKG/EU

- Cooling Air Velocity distribution  
(Discharge angle : 45 degree)

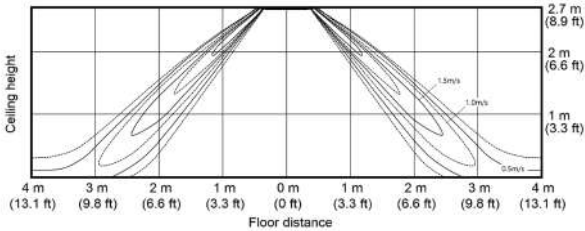

- Cooling temperature distribution  
(Discharge angle : 45 degree)

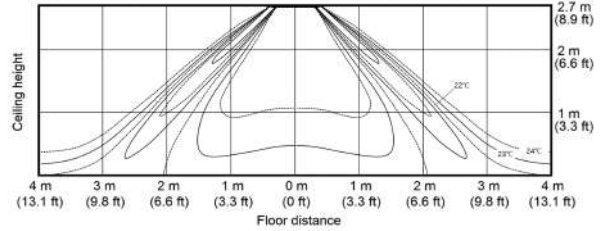

- Heating Air Velocity distribution  
(Discharge angle : 52 degree)

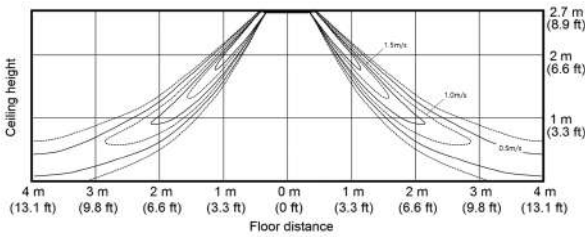

- Heating temperature distribution  
(Discharge angle : 52 degree)

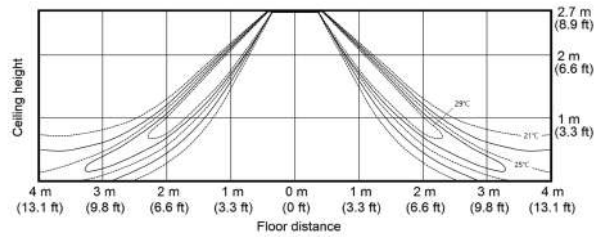

### AM090DN4DKG/EU

- Cooling Air Velocity distribution  
(Discharge angle : 45 degree)

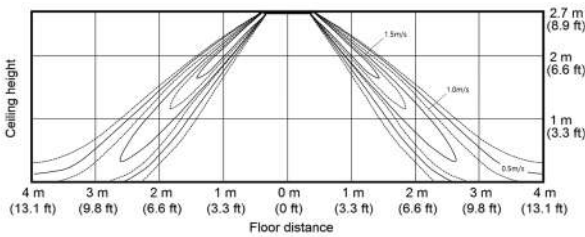

- Cooling temperature distribution  
(Discharge angle : 45 degree)

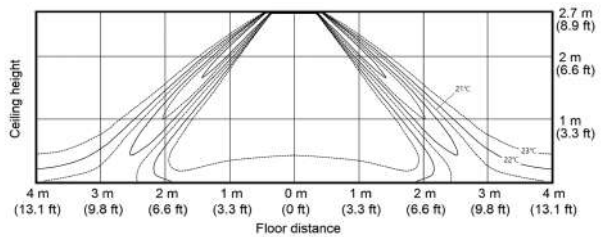

- Heating Air Velocity distribution  
(Discharge angle : 52 degree)

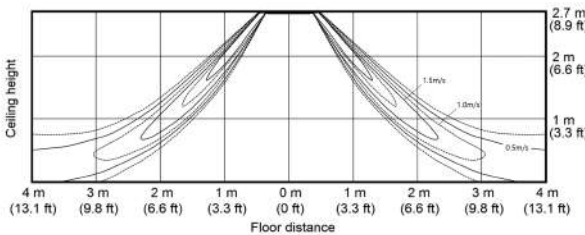

- Heating temperature distribution  
(Discharge angle : 52 degree)

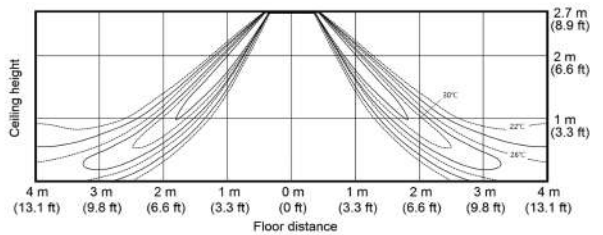

# 8. Temperature and air flow distribution

## WindFree™ 4Way Cassette

### AM112DN4DKG/EU

- Cooling Air Velocity distribution  
(Discharge angle : 45 degree)

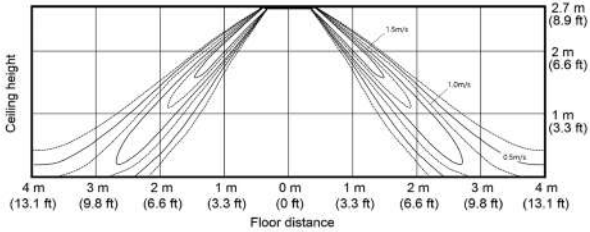

- Cooling temperature distribution  
(Discharge angle : 45 degree)

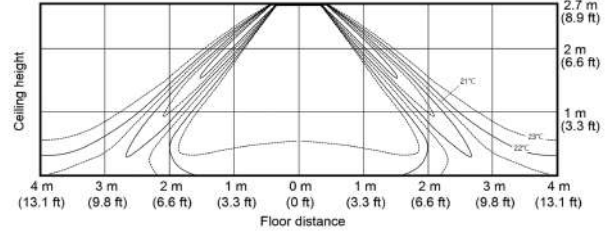

- Heating Air Velocity distribution  
(Discharge angle : 52 degree)

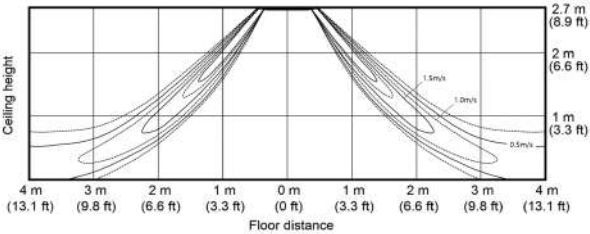

- Heating temperature distribution  
(Discharge angle : 52 degree)

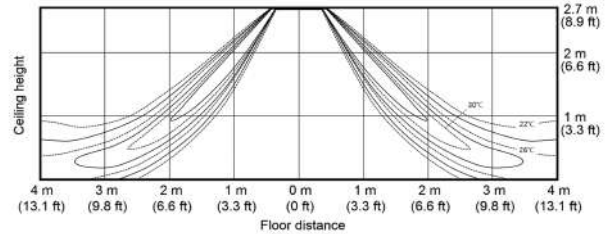

### AM128DN4DKG/EU

- Cooling Air Velocity distribution  
(Discharge angle : 45 degree)

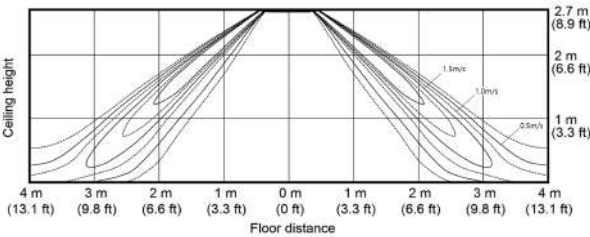

- Cooling temperature distribution  
(Discharge angle : 45 degree)

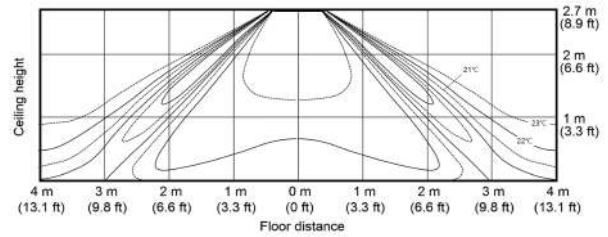

- Heating Air Velocity distribution  
(Discharge angle : 52 degree)

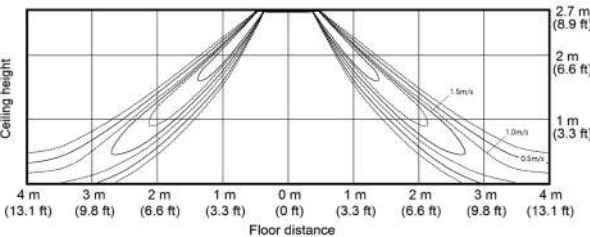

- Heating temperature distribution  
(Discharge angle : 52 degree)

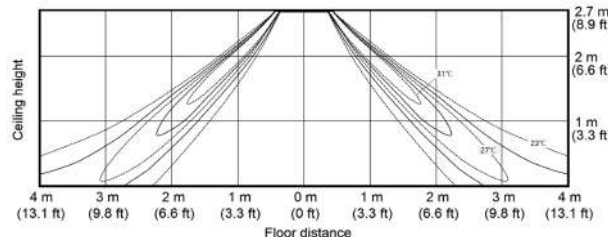

# 8. Temperature and air flow distribution

## WindFree™ 4Way Cassette

### AM140DN4DKG/EU

- Cooling Air Velocity distribution  
(Discharge angle : 45 degree)

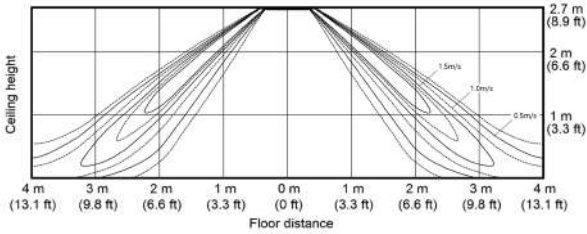

- Cooling temperature distribution  
(Discharge angle : 45 degree)

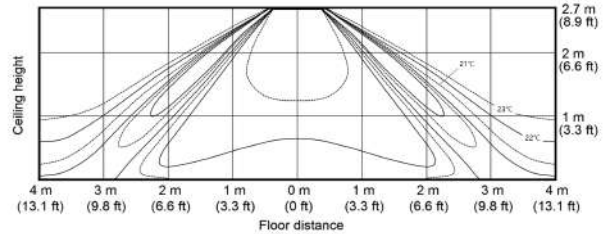

- Heating Air Velocity distribution  
(Discharge angle : 52 degree)

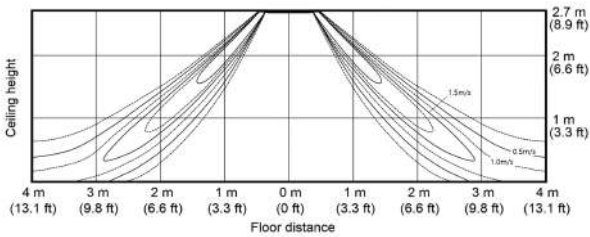

- Heating temperature distribution  
(Discharge angle : 52 degree)

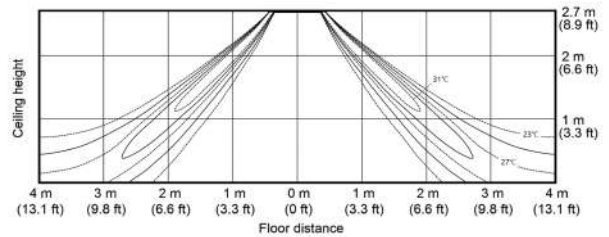

### AM022DN4FKG/EU

- Cooling Air Velocity distribution  
(Discharge angle : 45 degree)

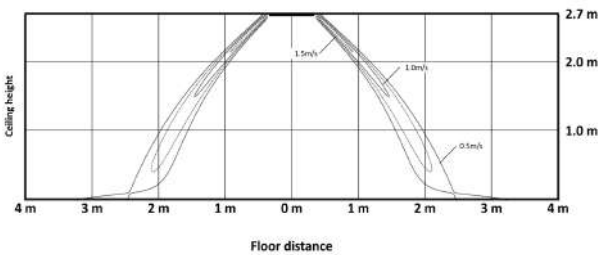

- Cooling temperature distribution  
(Discharge angle : 45 degree)

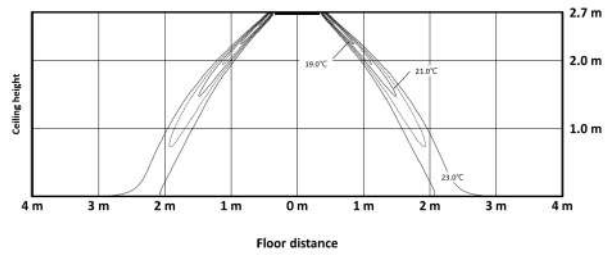

- Heating Air Velocity distribution  
(Discharge angle : 52 degree)

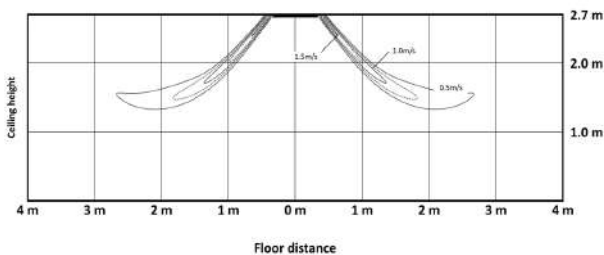

- Heating temperature distribution  
(Discharge angle : 52 degree)

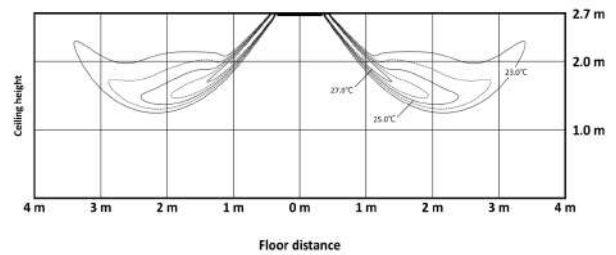

# 8. Temperature and air flow distribution

## WindFree™ 4Way Cassette

### AM028DN4FKG/EU

- Cooling Air Velocity distribution  
(Discharge angle : 45 degree)

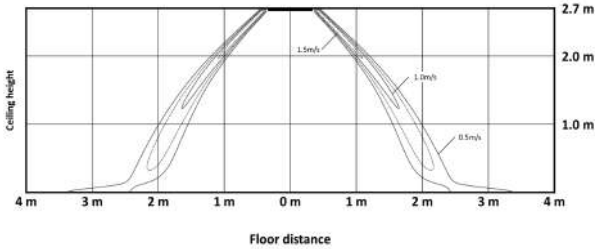

- Cooling temperature distribution  
(Discharge angle : 45 degree)

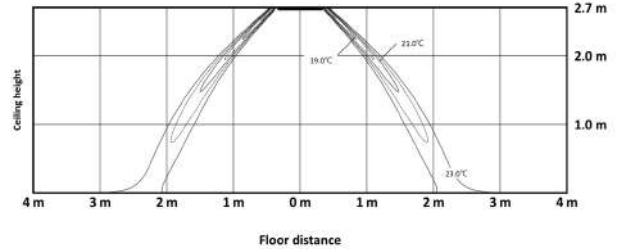

- Heating Air Velocity distribution  
(Discharge angle : 52 degree)

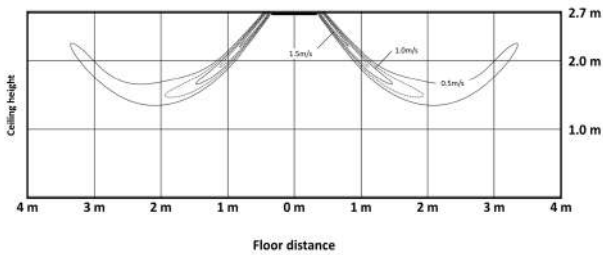

- Heating temperature distribution  
(Discharge angle : 52 degree)

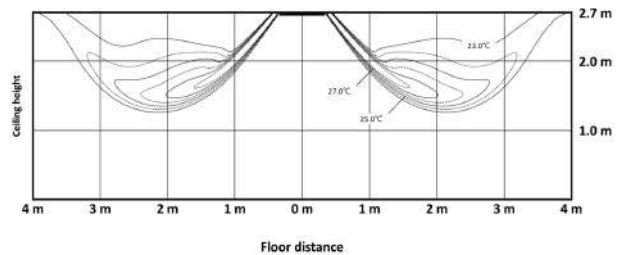

### AM036DN4FKG/EU

- Cooling Air Velocity distribution  
(Discharge angle : 45 degree)

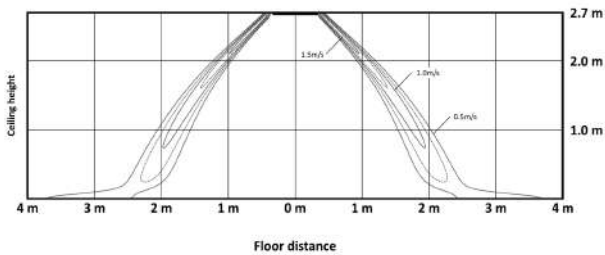

- Cooling temperature distribution  
(Discharge angle : 45 degree)

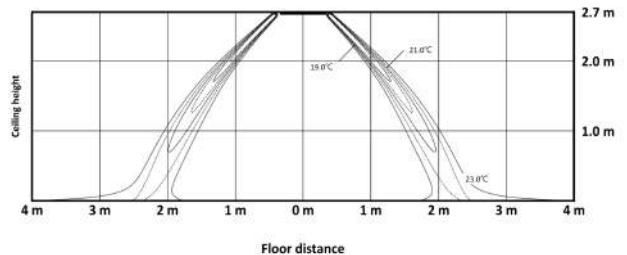

- Heating Air Velocity distribution  
(Discharge angle : 52 degree)

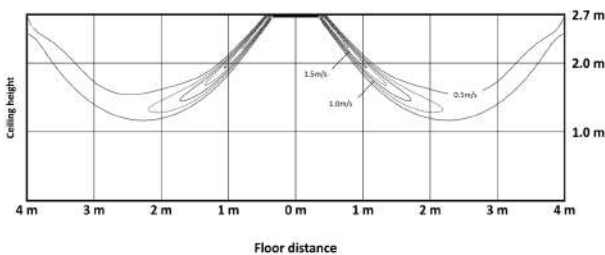

- Heating temperature distribution  
(Discharge angle : 52 degree)

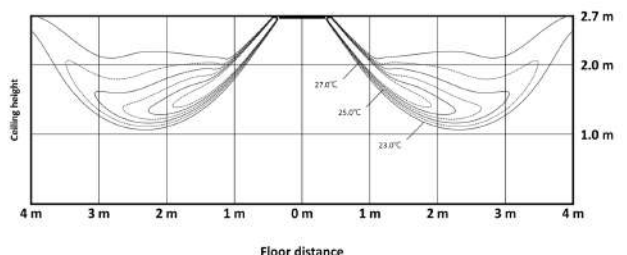

# 8. Temperature and air flow distribution

## WindFree™ 4Way Cassette

### AM045DN4FKG/EU

- Cooling Air Velocity distribution  
(Discharge angle : 45 degree)

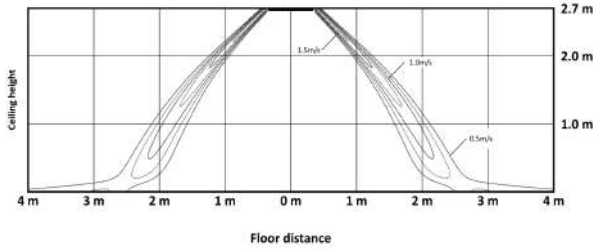

- Cooling temperature distribution  
(Discharge angle : 45 degree)

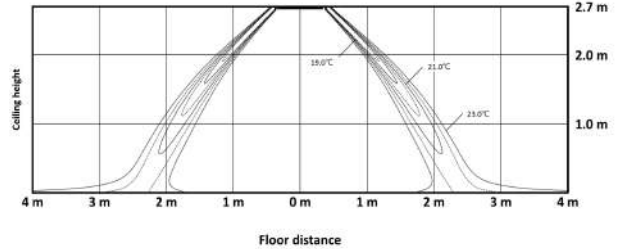

- Heating Air Velocity distribution  
(Discharge angle : 52 degree)

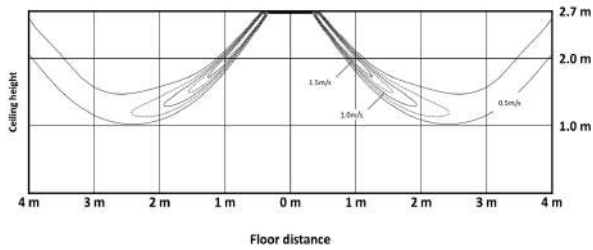

- Heating temperature distribution  
(Discharge angle : 52 degree)

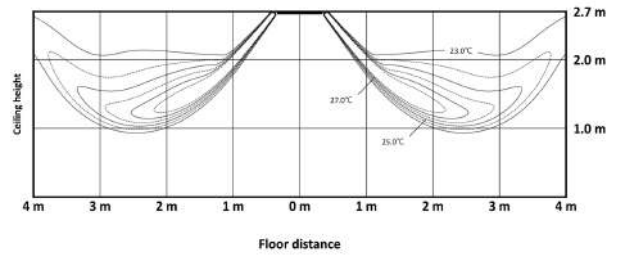

### AM056DN4FKG/EU

- Cooling Air Velocity distribution  
(Discharge angle : 45 degree)

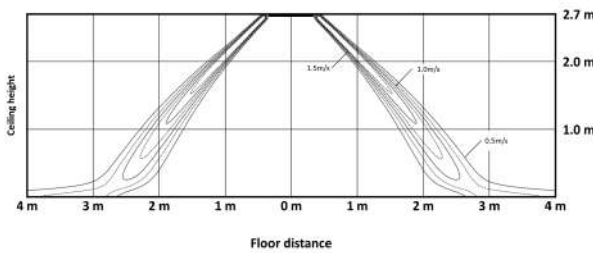

- Cooling temperature distribution  
(Discharge angle : 45 degree)

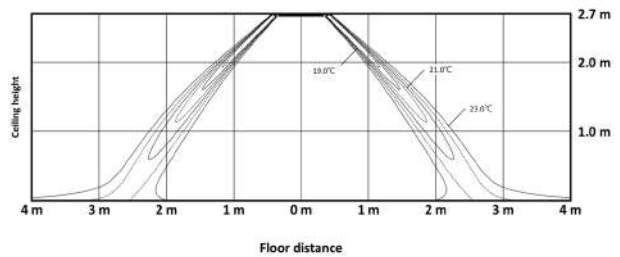

- Heating Air Velocity distribution  
(Discharge angle : 52 degree)

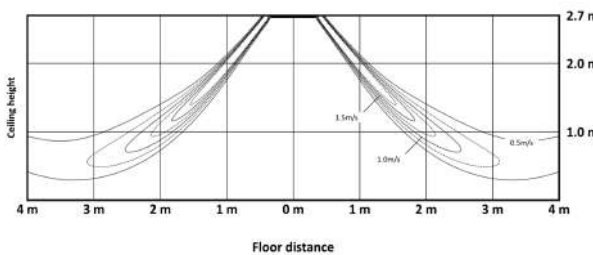

- Heating temperature distribution  
(Discharge angle : 52 degree)

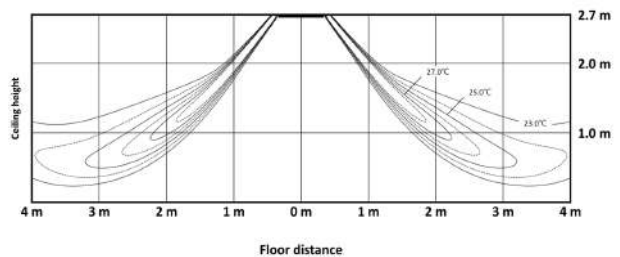

# 8. Temperature and air flow distribution

## WindFree™ 4Way Cassette

### AM071DN4FKG/EU

- Cooling Air Velocity distribution  
(Discharge angle : 45 degree)

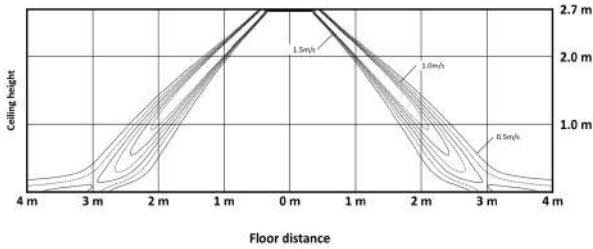

- Cooling temperature distribution  
(Discharge angle : 45 degree)

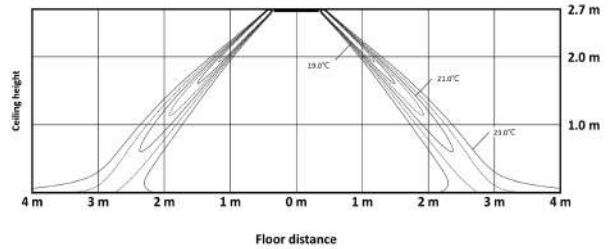

- Heating Air Velocity distribution  
(Discharge angle : 52 degree)

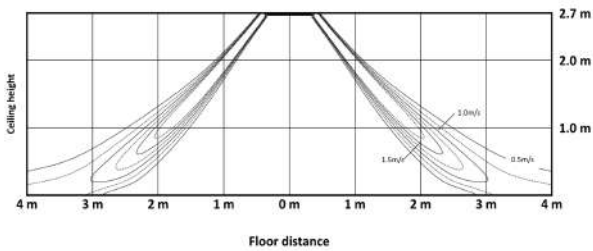

- Heating temperature distribution  
(Discharge angle : 52 degree)

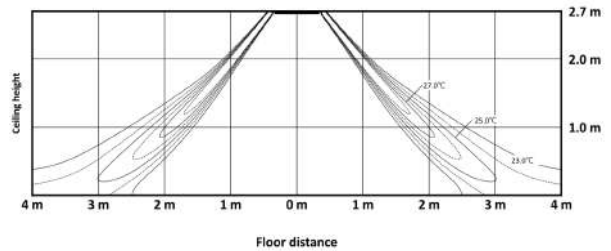

# 9. Piping Diagram

## WindFree™ 4Way Cassette

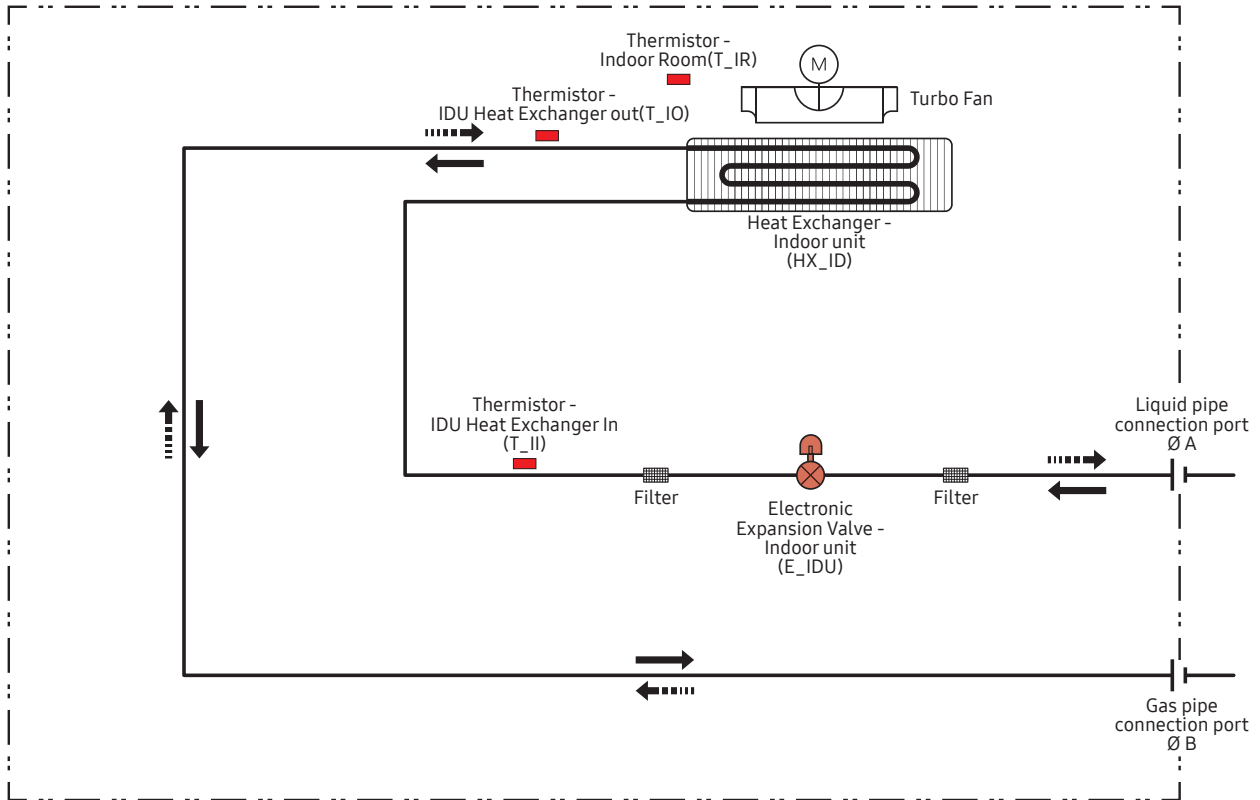

Refrigerant flow	
Cooling	Heating

# 360 Cassette

---

1. Specification	88
2. Summary Table	92
3. Capacity Table	93
4. Dimensional Drawing	94
5. Center of Gravity	102
6. Electrical Wiring Diagram	103
7. Sound Data	104
8. Temperature and air flow distribution	108
9. Piping Diagram	112

---

# Line-up

## 360 Cassette

Capacity (kW)						
4.5	5.6	7.1	9.0	11.2	12.8	14.0
						

# 1. Specification

## 360 Cassette

Model Name				AM045DN6DKG/EU	AM056DN6DKG/EU	AM071DN6DKG/EU	AM090DN6DKG/EU
Power Supply			Φ, #, V, Hz	1,2,220-240,50/60	1,2,220-240,50/60	1,2,220-240,50/60	1,2,220-240,50/60
Performance	Capacity	Cooling	kW	4.50	5.60	7.10	9.00
			Btu/h	15,400	19,100	24,200	30,700
		Heating	kW	5.00	6.30	8.00	10.00
			Btu/h	17,100	21,500	27,300	34,100
Power	Power Input	Cooling	W	26.00	30.00	34.00	55.00
		Heating		26.00	30.00	34.00	55.00
	Current Input	Cooling	A	0.18	0.21	0.25	0.42
		Heating		0.18	0.21	0.25	0.42
	Current	MCA	A	0.40	0.43	0.47	0.60
		MFA		15	15	15	15
Heat exchanger	Type		-	Fin & Tube	Fin & Tube	Fin & Tube	Fin & Tube
	Material	Fin	-	Al	Al	Al	Al
		Tube	-	Cu	Cu	Cu	Cu
	Fin Treatment		-	Green Hydrophile	Green Hydrophile	Green Hydrophile	Green Hydrophile
Fan	Type	Type	-	Turbo Fan	Turbo Fan	Turbo Fan	Turbo Fan
	Quantity		ea	1	1	1	1
	Air Flow Rate	H/M/L	CMM	14.5 / 13.5 / 12.5	16.0 / 14.5 / 13.5	18.0 / 16.0 / 14.0	22.0 / 18.5 / 16.0
			l/s	242 / 225 / 208	267 / 242 / 225	300 / 267 / 233	367 / 308 / 267
Fan Motor	Model		-	BLDC Motor	BLDC Motor	BLDC Motor	BLDC Motor
	Output x n		W	65 x 1	65 x 1	65 x 1	65 x 1
Piping Connections	Liquid Pipe	Type		Flare connection	Flare connection	Flare connection	Flare connection
		Φ,mm		6.35	6.35	9.52	9.52
		Φ, inch		1/4	1/4	3/8	3/8
	Gas Pipe	Type		Flare connection	Flare connection	Flare connection	Flare connection
		Φ,mm		12.70	12.70	15.88	15.88
		Φ, inch		1/2	1/2	5/8	5/8
	Heat insulation		-	Both liquid & gas pipes	Both liquid & gas pipes	Both liquid & gas pipes	Both liquid & gas pipes
Drain Pipe		Φ,mm	VP25 (OD 32,ID 25)	VP25 (OD 32,ID 25)	VP25 (OD 32,ID 25)	VP25 (OD 32,ID 25)	
Wiring connections	Communication	Min.	mm <sup>2</sup>	0.75	0.75	0.75	0.75
	Remark		-	F1, F2	F1, F2	F1, F2	F1, F2
Refrigerant	Type		-	R32	R32	R32	R32
	Electronic Expansion Valve		-	EEV INCLUDED	EEV INCLUDED	EEV INCLUDED	EEV INCLUDED
Sound Level	Sound Pressure Level	H/M/L	dB(A)	33 / 31 / 29	34 / 32 / 29	36 / 33 / 30	40 / 36 / 32
	Sound Power Level	Cooling		50	51	53	57
Dimensions	Net Weight		kg	21.0	21.0	21.0	20.0
	Shipping Weight		kg	25.9	25.9	25.9	25.5
	Net Dimensions (W×H×D)		mm	947 x 281 x 947	947 x 281 x 947	947 x 281 x 947	947 x 281 x 947
	Shipping Dimensions (W×H×D)		mm	990 x 330 x 990	990 x 330 x 990	990 x 330 x 990	990 x 330 x 990

# 1. Specification

## 360 Cassette

Model Name			AM045DN6DKG/EU	AM056DN6DKG/EU	AM071DN6DKG/EU	AM090DN6DKG/EU
Panel(1)	Model Name	-	PC6NUSMANW	PC6NUSMANW	PC6NUSMANW	PC6NUSMANW
	Type	-	Ceiling Type(Square)	Ceiling Type(Square)	Ceiling Type(Square)	Ceiling Type(Square)
	Material	-	HIPS	HIPS	HIPS	HIPS
	Color	-	White	White	White	White
	Net Weight	kg	3.8	3.8	3.8	3.8
	Shipping Weight	kg	6.3	6.3	6.3	6.3
	Net Dimensions (W×H×D)	mm	1,000 x 74 x 1,000	1,000 x 74 x 1,000	1,000 x 74 x 1,000	1,000 x 74 x 1,000
	Shipping Dimensions (W×H×D)	mm	1,093 x 85 x 1,083	1,093 x 85 x 1,083	1,093 x 85 x 1,083	1,093 x 85 x 1,083
Panel(2)	Model Name	-	PC6EUSMANW	PC6EUSMANW	PC6EUSMANW	PC6EUSMANW
	Type	-	Open Type(Circle)	Open Type(Circle)	Open Type(Circle)	Open Type(Circle)
	Material	-	HIPS	HIPS	HIPS	HIPS
	Color	-	White	White	White	White
	Net Weight	kg	2.8	2.8	2.8	2.8
	Shipping Weight	kg	5.3	5.3	5.3	5.3
	Net Dimensions (W×H×D)	mm	1,050 x 106 x 1,050	1,050 x 106 x 1,050	1,050 x 106 x 1,050	1,050 x 106 x 1,050
	Shipping Dimensions (W×H×D)	mm	1,093 x 85 x 1,083	1,093 x 85 x 1,083	1,093 x 85 x 1,083	1,093 x 85 x 1,083
Drain Pump	Drain Pump	-	INCLUDED	INCLUDED	INCLUDED	INCLUDED
	Max. lifting Height / Displacement	mm / Liter/h	750 / 24	750 / 24	750 / 24	750 / 24

### NOTE

- Specification may be subject to change without prior notice.
  - 1) Capacities are based on (Equivalent refrigerant piping 7.5m, Level differences 0m);
    - Cooling : Indoor temperature 27°C DB, 19°C WB / Outdoor temperature 35°C DB, 24°C WB
    - Heating : Indoor temperature 20°C DB, 15°C WB / Outdoor temperature 7°C DB, 6°C WB
  - 2) Sound level was acquired in an anechoic room. Thus actual noise level may be different depending on the installation conditions.
  - 3) These products contain R32 (GWP=675) which is fluorinated greenhouse gas.
  - 4) Select wire size based on the value of MCA

# 1. Specification

## 360 Cassette

Model Name				AM112DN6DKG/EU	AM128DN6DKG/EU	AM140DN6DKG/EU
Power Supply			Φ, #, V, Hz	1,2,220-240,50/60	1,2,220-240,50/60	1,2,220-240,50/60
Performance	Capacity	Cooling	kW	11.20	12.80	14.00
			Btu/h	38,200	43,700	47,800
		Heating	kW	12.50	13.80	16.00
			Btu/h	42,700	47,100	54,600
Power	Power Input	Cooling	W	53.00	77.00	91.00
		Heating		53.00	77.00	91.00
	Current Input	Cooling	A	0.41	0.62	0.75
		Heating		0.41	0.62	0.75
	Current	MCA	A	0.80	1.00	1.13
		MFA		15	15	15
Heat exchanger	Type		-	Fin & Tube	Fin & Tube	Fin & Tube
	Material	Fin	-	Al	Al	Al
		Tube	-	Cu	Cu	Cu
	Fin Treatment		-	Green Hydrophile	Green Hydrophile	Green Hydrophile
Fan	Type	Type	-	Turbo Fan	Turbo Fan	Turbo Fan
	Quantity		ea	1	1	1
	Air Flow Rate	H/M/L	CMM	25.5 / 21.0 / 17.5	29.5 / 24.0 / 19.0	31.5 / 26.5 / 21.0
			l/s	425 / 350 / 292	492 / 400 / 317	525 / 442 / 350
Fan Motor	Model		-	BLDC Motor	BLDC Motor	BLDC Motor
	Output x n		W	97 x 1	97 x 1	97 x 1
Piping Connections	Liquid Pipe	Type		Flare connection	Flare connection	Flare connection
		Φ,mm		9.52	9.52	9.52
		Φ, inch		3/8	3/8	3/8
	Gas Pipe	Type		Flare connection	Flare connection	Flare connection
		Φ,mm		15.88	15.88	15.88
		Φ, inch		5/8	5/8	5/8
	Heat insulation		-	Both liquid & gas pipes	Both liquid & gas pipes	Both liquid & gas pipes
Drain Pipe		Φ,mm	VP25 (OD 32,ID 25)	VP25 (OD 32,ID 25)	VP25 (OD 32,ID 25)	
Wiring connections	Communication	Min.	mm <sup>2</sup>	0.75	0.75	0.75
		Remark	-	F1, F2	F1, F2	F1, F2
Refrigerant	Type		-	R32	R32	R32
	Electronic Expansion Valve		-	EEV INCLUDED	EEV INCLUDED	EEV INCLUDED
Sound Level	Sound Pressure Level	H/M/L	dB(A)	40 / 36 / 32	42 / 38 / 33	44 / 40 / 35
	Sound Power Level	Cooling		58	60	61
Dimensions	Net Weight		kg	24.0	24.0	24.0
	Shipping Weight		kg	29.4	29.4	29.4
	Net Dimensions (W×H×D)		mm	947 x 365 x 947	947 x 365 x 947	947 x 365 x 947
	Shipping Dimensions (W×H×D)		mm	990 x 414 x 990	990 x 414 x 990	990 x 414 x 990

# 1. Specification

## 360 Cassette

Model Name			AM112DN6DKG/EU	AM128DN6DKG/EU	AM140DN6DKG/EU
Panel(1)	Model Name	-	PC6NUSMANW	PC6NUSMANW	PC6NUSMANW
	Type	-	Ceiling Type(Square)	Ceiling Type(Square)	Ceiling Type(Square)
	Material	-	HIPS	HIPS	HIPS
	Color	-	White	White	White
	Net Weight	kg	3.8	3.8	3.8
	Shipping Weight	kg	6.3	6.3	6.3
	Net Dimensions (W×H×D)	mm	1,000 x 74 x 1,000	1,000 x 74 x 1,000	1,000 x 74 x 1,000
	Shipping Dimensions (W×H×D)	mm	1,093 x 85 x 1,083	1,093 x 85 x 1,083	1,093 x 85 x 1,083
Panel(2)	Model Name	-	PC6EUSMANW	PC6EUSMANW	PC6EUSMANW
	Type	-	Open Type(Circle)	Open Type(Circle)	Open Type(Circle)
	Material	-	HIPS	HIPS	HIPS
	Color	-	White	White	White
	Net Weight	kg	2.8	2.8	2.8
	Shipping Weight	kg	5.3	5.3	5.3
	Net Dimensions (W×H×D)	mm	1,050 x 106 x 1,050	1,050 x 106 x 1,050	1,050 x 106 x 1,050
	Shipping Dimensions (W×H×D)	mm	1,093 x 85 x 1,083	1,093 x 85 x 1,083	1,093 x 85 x 1,083
Drain Pump	Drain Pump	-	INCLUDED	INCLUDED	INCLUDED
	Max. lifting Height / Displacement	mm / Liter/h	750 / 24	750 / 24	750 / 24

### NOTE

- Specification may be subject to change without prior notice.
  - 1) Capacities are based on (Equivalent refrigerant piping 7.5m, Level differences 0m);
    - Cooling : Indoor temperature 27°C DB, 19°C WB / Outdoor temperature 35°C DB, 24°C WB
    - Heating : Indoor temperature 20°C DB, 15°C WB / Outdoor temperature 7°C DB, 6°C WB
  - 2) Sound level was acquired in an anechoic room. Thus actual noise level may be different depending on the installation conditions.
  - 3) These products contain R32 (GWP=675) which is fluorinated greenhouse gas.
  - 4) Select wire size based on the value of MCA

## 2. Summary Table

### 360 Cassette

#### Performance Characteristics

Model Code	Net Weight (kg)	Fan Speed	Nominal Capacity (kW)			Airflow (CMM)	Sound Pressure (dBA)	Sound Power (dBA)
			Cooling	Sensible	Heating			
AM045DN6DKG/EU	21.0	High	4.5	3.1	5.0	14.5	33	50
		Mid	4.2	2.9	4.8	13.5	31	-
		Low	4.0	2.8	4.6	12.5	29	-
AM056DN6DKG/EU	21.0	High	5.6	3.9	6.3	16.0	34	51
		Mid	5.1	3.6	6.0	14.5	21	-
		Low	4.8	3.3	5.8	13.5	29	-
AM071DN6DKG/EU	21.0	High	7.1	5.0	8.0	18.0	36	53
		Mid	6.4	4.5	7.5	16.0	33	-
		Low	5.7	4.0	7.1	14.0	30	-
AM090DN6DKG/EU	20.0	High	9.0	6.3	10.0	22.0	40	57
		Mid	7.7	5.4	9.2	18.5	36	-
		Low	6.7	4.7	8.5	16.0	32	-
AM112DN6DKG/EU	24.0	High	11.2	7.9	12.5	25.5	40	58
		Mid	9.4	6.6	11.3	21.0	36	-
		Low	7.9	5.6	10.4	17.5	32	-
AM128DN6DKG/EU	24.0	High	12.8	9.1	13.8	29.5	42	60
		Mid	10.7	7.6	12.4	24.0	38	-
		Low	8.5	6.0	11.1	19.0	33	-
AM140DN6DKG/EU	24.0	High	14.0	9.6	16.0	31.5	44	61
		Mid	12.0	8.2	14.7	26.5	40	-
		Low	9.6	6.6	13.1	21.0	35	-

#### NOTE

- Sound data is based on cooling operation.

#### Electric Characteristics

Indoor Unit	Power Supply (Ø, #, V, Hz)	Power Input (W)	Current Input (A)	MCA (A)	MFA (A)	FLA (A)
AM045DN6DKG/EU	1,2,220~240,50/60	26.0	0.18	0.40	15	0.32
AM056DN6DKG/EU	1,2,220~240,50/60	30.0	0.21	0.43	15	0.34
AM071DN6DKG/EU	1,2,220~240,50/60	34.0	0.25	0.47	15	0.38
AM090DN6DKG/EU	1,2,220~240,50/60	55.0	0.42	0.60	15	0.48
AM112DN6DKG/EU	1,2,220~240,50/60	53.0	0.41	0.80	15	0.64
AM128DN6DKG/EU	1,2,220~240,50/60	77.0	0.62	1.00	15	0.80
AM140DN6DKG/EU	1,2,220~240,50/60	91.0	0.75	1.13	15	0.90

#### NOTE

- MCA : Minimum circuit amperes
- MFA : Maximum fuse amperes
- Select wire size based on the value of MCA

# 3. Capacity Table

## 360 Cassette

### Cooling

TC : Total Capacity, SHC : Sensible Heat Capacity

Capacity Index	Outdoor Air Temp. (°C, DB)	Indoor temperature													
		20(°C, DB)		23(°C, DB)		26(°C, DB)		27(°C, DB)		28(°C, DB)		30(°C, DB)		32(°C, DB)	
		14(°C, WB)		16(°C, WB)		18(°C, WB)		19(°C, WB)		20(°C, WB)		22(°C, WB)		24(°C, WB)	
		TC	SHC	TC	SHC	TC	SHC	TC	SHC	TC	SHC	TC	SHC	TC	SHC
045	35	3.1	2.7	3.7	2.8	4.2	3.0	4.5	3.1	4.7	3.1	5.0	3.1	5.3	2.8
056	35	3.9	3.2	4.6	3.5	5.3	3.9	5.6	3.9	5.8	3.9	6.2	3.8	6.6	3.6
071	35	4.9	4.0	5.8	4.5	6.7	4.8	7.1	5.0	7.4	5.0	7.9	5.0	8.4	4.8
090	35	6.2	5.2	7.3	5.7	8.4	6.3	9.0	6.3	9.3	6.3	10.0	6.2	10.6	6.1
112	35	7.7	6.3	9.1	7.0	10.5	7.8	11.2	7.9	11.6	7.9	12.4	7.9	13.2	7.7
128	35	8.8	7.3	10.4	8.1	12.0	9.0	12.8	9.1	13.3	9.1	14.2	9.0	15.1	8.8
140	35	9.7	7.7	11.4	8.5	13.1	9.4	14.0	9.6	14.5	9.6	15.5	9.5	16.5	9.4

### Heating

TC : Total Capacity (kW)

Capacity Index	Outdoor Air Temp. (°C)		Indoor temperature (°C, DB)				
			16(°C, DB)	18(°C, DB)	20(°C, DB)	22(°C, DB)	24(°C, DB)
			TC	TC	TC	TC	TC
	DB	WB	kW	kW	kW	kW	kW
045	7.0	6.0	5.1	5.1	5.0	4.6	4.2
056	7.0	6.0	6.5	6.4	6.3	5.8	5.3
071	7.0	6.0	8.2	8.1	8.0	7.4	6.8
090	7.0	6.0	10.3	10.1	10.0	9.2	8.4
112	7.0	6.0	12.9	12.7	12.5	11.5	10.6
128	7.0	6.0	14.2	14.0	13.8	12.7	11.7
140	7.0	6.0	16.5	16.2	16.0	14.8	13.5

### NOTE

- The performance table shows the average value of each conditions.

# 4. Dimensional Drawing

## 360 Cassette (Square)

AM045DN6DKG/EU, AM056DN6DKG/EU, AM071DN6DKG/EU, AM090DN6DKG/EU

Units : mm [inches]

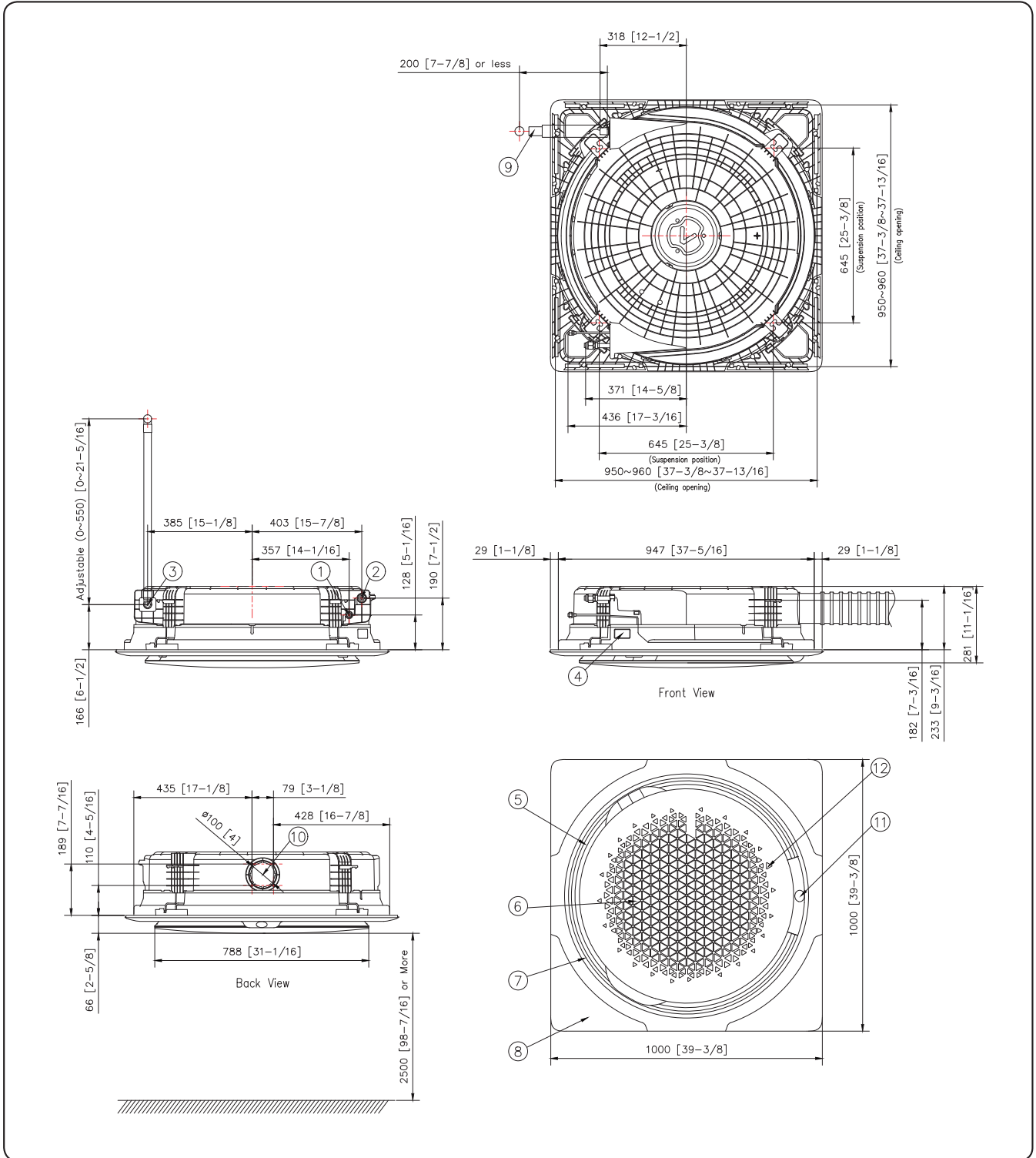

## 4. Dimensional Drawing

### 360 Cassette (Square)

No.	Name	Description	
		AM045DN6DKG/EU AM056DN6DKG/EU	AM071DN6DKG/EU AM090DN6DKG/EU
1	Liquid pipe connection	Φ6.35[1/4]	Φ9.52[3/8]
2	Gas pipe connection	Φ12.7[1/2]	Φ15.88[5/8]
3	Drain pipe connection	VP25 (OD32, ID25)	
4	Power supply & Communication wiring conduit	-	
5	Air Discharge opening	-	
6	Air suction grille	-	
7	Suction rim for Booster fan	-	
8	Decoration cover	-	
9	Drain hose (Accessory)	-	
10	Fresh air intake knockout hole	Use M4 Screw	
11	Display Window	-	
12	Remote controller receiver	-	

#### NOTE

- As for suspension bolt, please use M8 ~ M10. (Procured at local site)
- Make sure the spacing between the ceiling and the cassette is no more than 29mm[1-1/4].  
Max ceiling opening : 960mm[36-13/16].
- When the condition exceed 30°C and RH 80% in the ceiling or fresh air is inducted into the ceiling, and additional insulation is required (polyethylene foam , thickness 10mm[3/8] or more)

# 4. Dimensional Drawing

## 360 Cassette (Square)

AM112DN6DKG/EU, AM128DN6DKG/EU, AM140DN6DKG/EU

Units : mm [inches]

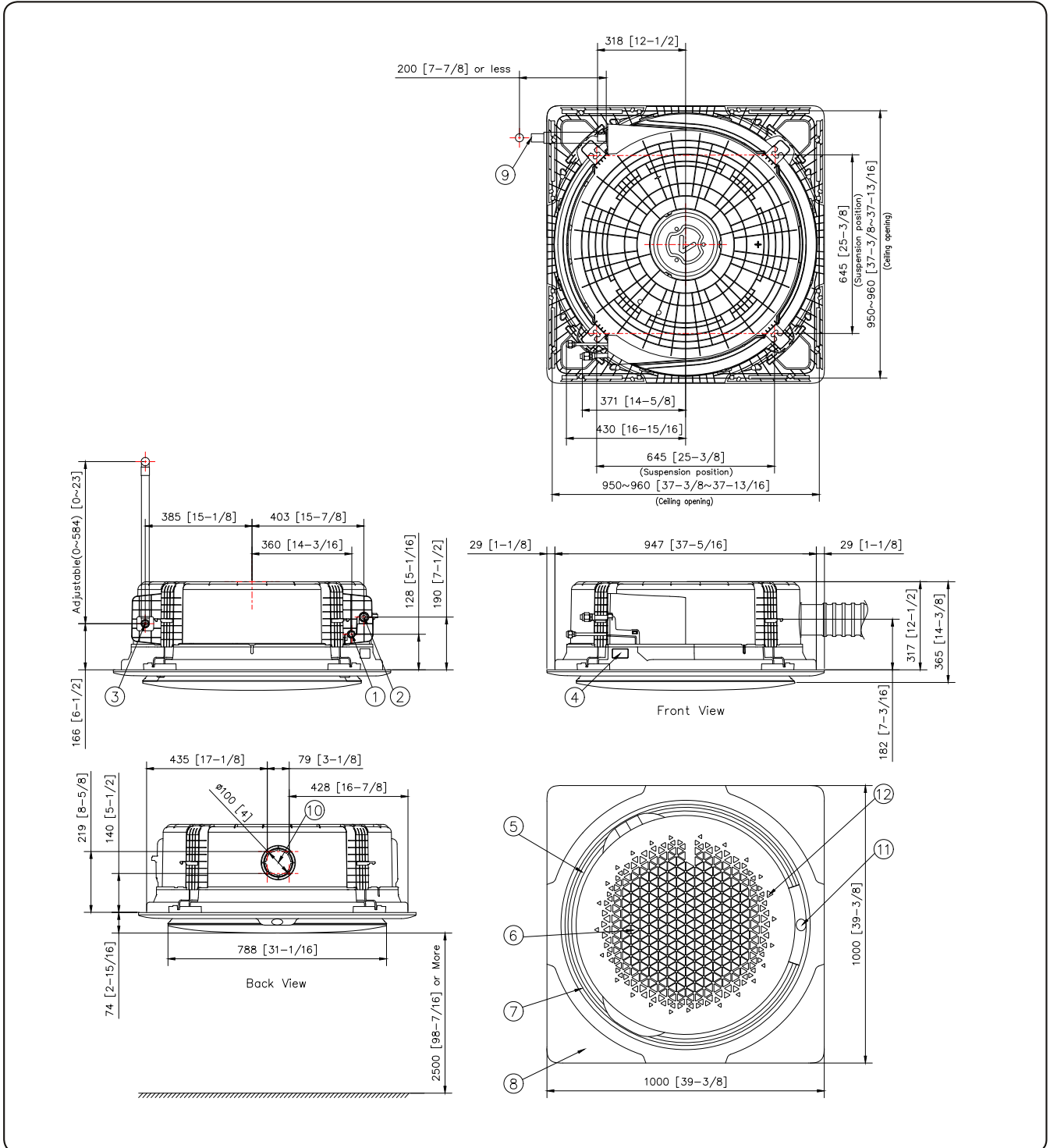

# 4. Dimensional Drawing

## 360 Cassette (Square)

No.	Name	Description
1	Liquid pipe connection	Φ9.52[3/8]
2	Gas pipe connection	Φ15.88[5/8]
3	Drain pipe connection	VP-25(OD32, ID25)
4	Power supply & Communication wiring conduit	-
5	Air Discharge opening	-
6	Air suction grille	-
7	Suction rim for Booster fan	-
8	Decoration cover	-
9	Drain hose (Accessory)	-
10	Fresh air intake knockout hole	Use M4 Screw
11	Display Window	-
12	Remote controller receiver	-

### NOTE

- As for suspension bolt, please use M8 ~ M10. (Procured at local site)
- Make sure the spacing between the ceiling and the cassette is no more than 29mm[1-1/4].  
Max ceiling opening : 960mm[36-13/16].
- When the condition exceed 30°C and RH 80% in the ceiling or fresh air is inducted into the ceiling, and additional insulation is required (polyethylene foam , thickness 10mm[3/8] or more)

# 4. Dimensional Drawing

## 360 Cassette (Circular)

AM045DN6DKG/EU, AM056DN6DKG/EU, AM071DN6DKG/EU, AM090DN6DKG/EU

Units : mm [inches]

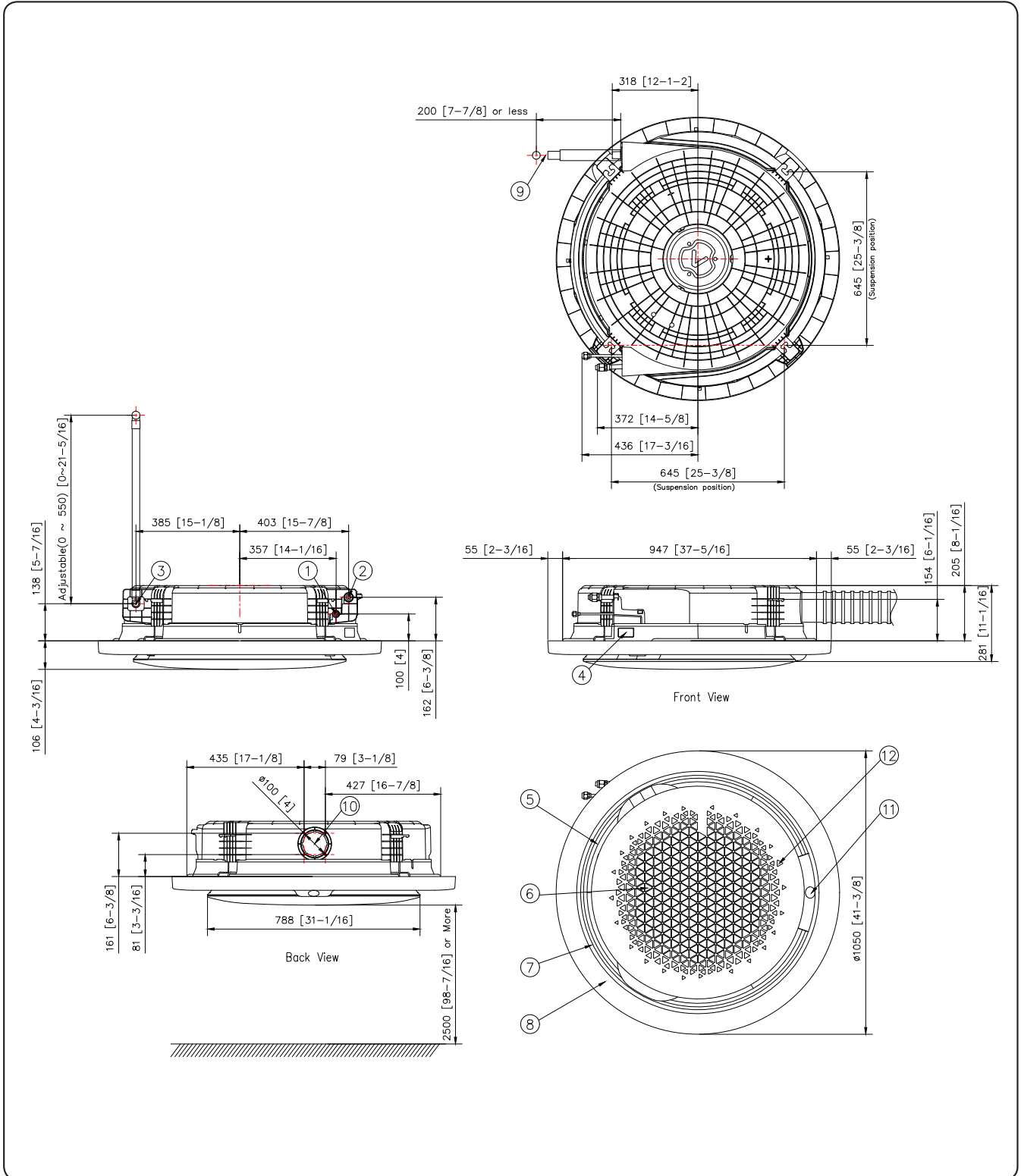

# 4. Dimensional Drawing

## 360 Cassette (Circular)

No.	Name	Description	
		AM045DN6DKG/EU AM056DN6DKG/EU	AM071DN6DKG/EU AM090DN6DKG/EU
1	Liquid pipe connection	Φ6.35[1/4]	Φ9.52[3/8]
2	Gas pipe connection	Φ12.7[1/2]	Φ15.88[5/8]
3	Drain pipe connection	VP25 (OD32, ID25)	
4	Power supply & Communication wiring conduit	-	
5	Air Discharge opening	-	
6	Air suction grille	-	
7	Suction rim for Booster fan	-	
8	Decoration cover	-	
9	Drain hose (Accessory)	-	
10	Fresh air intake knockout hole	Use M4 Screw	
11	Display Window	-	
12	Remote controller receiver	-	

### NOTE

- As for suspension bolt, please use M8 ~ M10. (Procured at local site)
- Make sure the spacing between the ceiling and the cassette is no more than 10mm[3/8]
- When the condition exceed 30°C and RH 80% in the ceiling or fresh air is inducted into the ceiling, and additional insulation is required (polyethylene foam , thiKness 10mm[3/8] or more)
- When installing the circular panel on the ceiling, make sure to install 2 or more inspection holes for the maintenance.
- The circular panel is by default available in exposed installation.  
Make inspection holes on the ceiling for easier installation and maintenance, as shown in the following table.  
(The size of an inspection hole must be at least 450 mm x 450 mm.)

Category	Inspection hole		
	Recessed installation		Exposed installation
	Integrated	suspended	
Square panel	1 ea	-	
Circular panel	2 ea		

- A suspended ceiling structure can substitute for the inspection holes.

# 4. Dimensional Drawing

## 360 Cassette (Circular)

AM112DN6DKG/EU, AM128DN6DKG/EU, AM140DN6DKG/EU

Units : mm [inches]

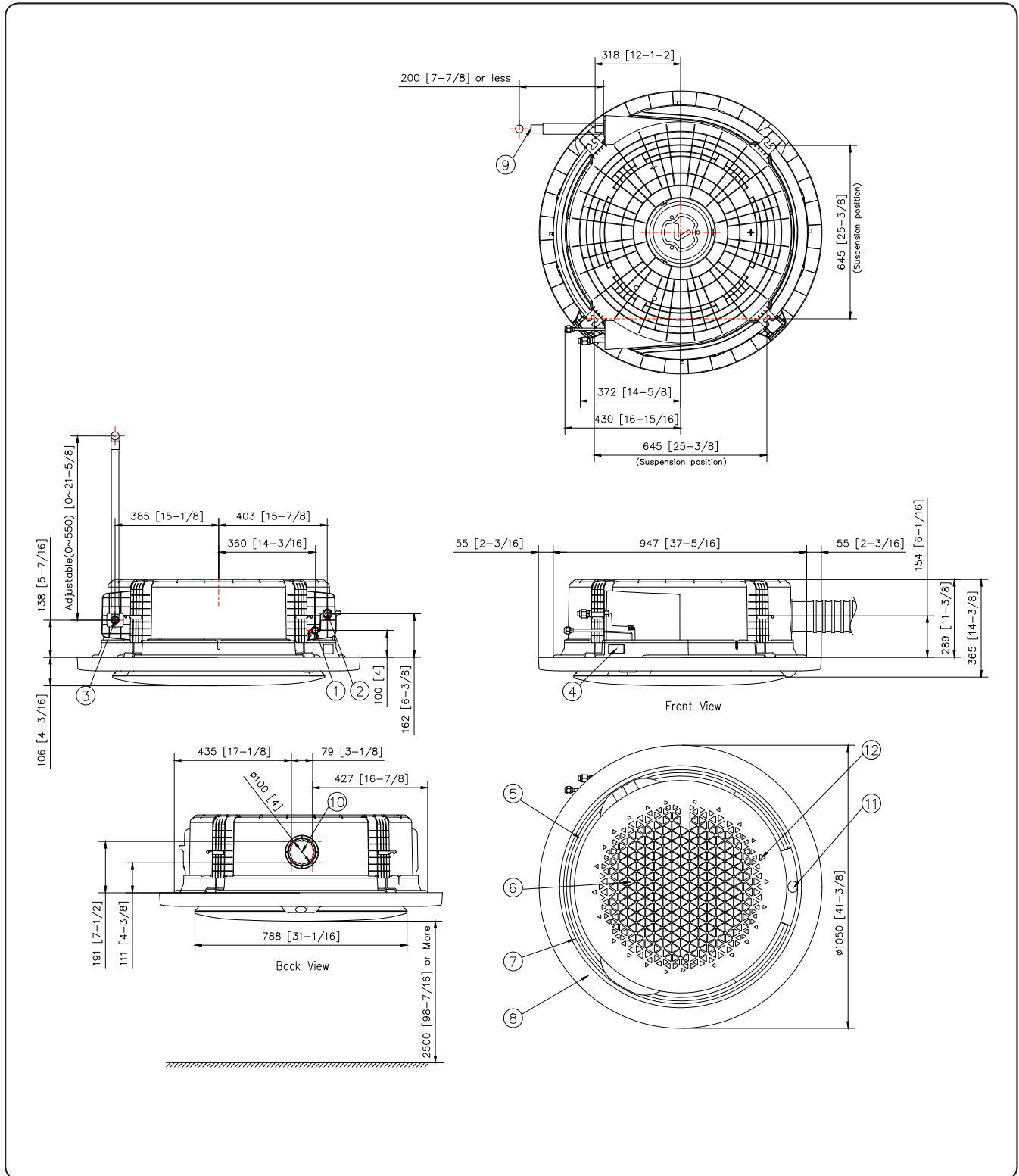

# 4. Dimensional Drawing

## 360 Cassette (Circular)

No.	Name	Description
1	Liquid pipe connection	Φ9.52[3/8]
2	Gas pipe connection	Φ15.88[5/8]
3	Drain pipe connection	VP-25(OD32, ID25)
4	Power supply & Communication wiring conduit	-
5	Air Discharge opening	-
6	Air suction grille	-
7	Suction rim for Booster fan	-
8	Decoration cover	-
9	Drain hose (Accessory)	-
10	Fresh air intake knockout hole	Use M4 Screw
11	Display Window	-
12	Remote controller receiver	-

### NOTE

- As for suspension bolt, please use M8 ~ M10. (Procured at local site)
- Make sure the spacing between the ceiling and the cassette is no more than 10mm[3/8]
- When the condition exceed 30°C and RH 80% in the ceiling or fresh air is inducted into the ceiling, and additional insulation is required (polyethylene foam , thiKness 10mm[3/8] or more)
- When installing the circular panel on the ceiling, make sure to install 2 or more inspection holes for the maintenance.
- The circular panel is by default available in exposed installation.  
Make inspection holes on the ceiling for easier installation and maintenance, as shown in the following table.  
(The size of an inspection hole must be at least 450 mm x 450 mm.)

Category	Inspection hole		
	Recessed installation		Exposed installation
	Integrated	suspended	
Square panel	1 ea	-	
Circular panel	2 ea		

- A suspended ceiling structure can substitute for the inspection holes.

# 5. Center of Gravity

## 360 Cassette

Units : mm [inches]

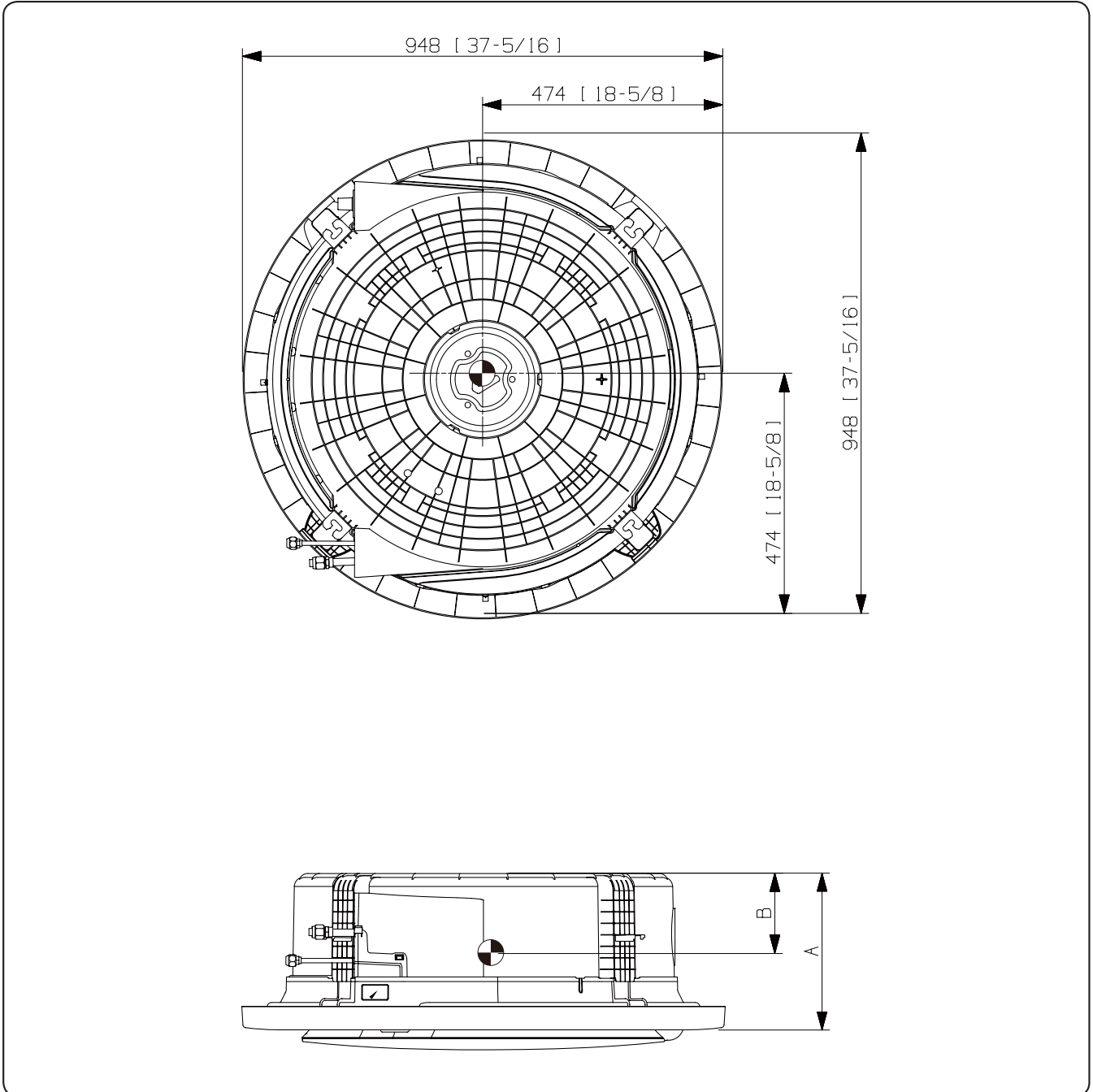

Model	A	B
AM045DN6DKG/EU AM056DN6DKG/EU AM071DN6DKG/EU AM090DN6DKG/EU	233 [9-3/16]	165 [6-1/2]
AM112DN6DKG/EU AM128DN6DKG/EU AM140DN6DKG/EU	317 [12-1/2]	220 [8-5/8]

# 6. Electrical Wiring Diagram

## 360 Cassette

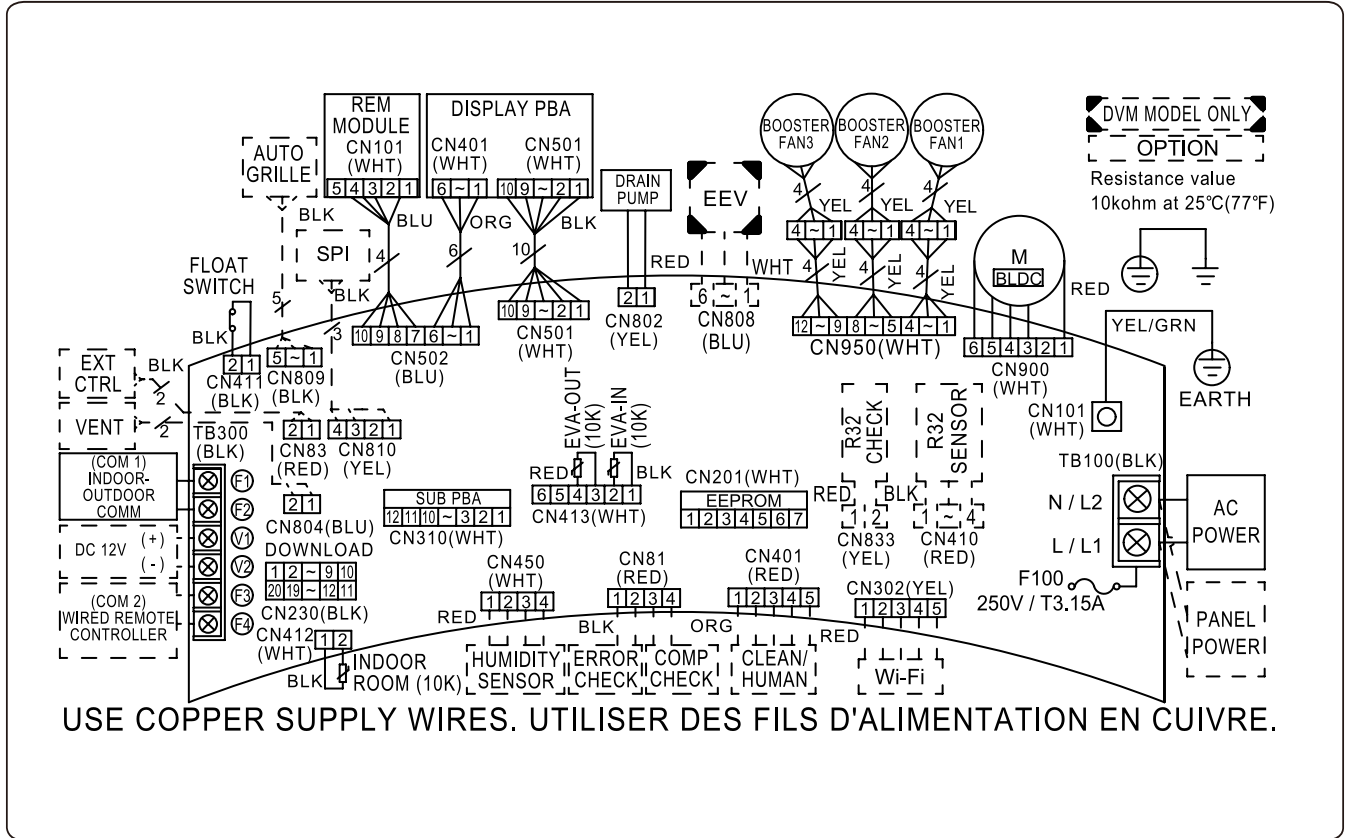

F100	FUSE	EEV	Electronic Expansion Valve	ROOM(10K)	Thermistor ROOM OUT(10K)
M-BLDC	BLDC Motor	EXT_CONTROL	EXTERNAL_CONTROL	EVA-IN(10K)	Thermistor EVA IN(10K)
				EVA-OUT(10K)	Thermistor EVA OUT(10K)

### NOTE

- This wiring diagram applies only to the Indoor unit.
- Symbols show as follow :  
blk: black, red: red, blu: blue, wht: white, yel: yellow, brn: brown, sky: skyblue: grn: green
- For connection wiring indoor-outdoor transmission F1-F2, indoor-wired remote controller transmission F3-F4.
- Protective earth(screw), : connector, : The wire quantity

# 7. Sound Data

## 360 Cassette

### Sound Pressure level

Unit: dB(A)

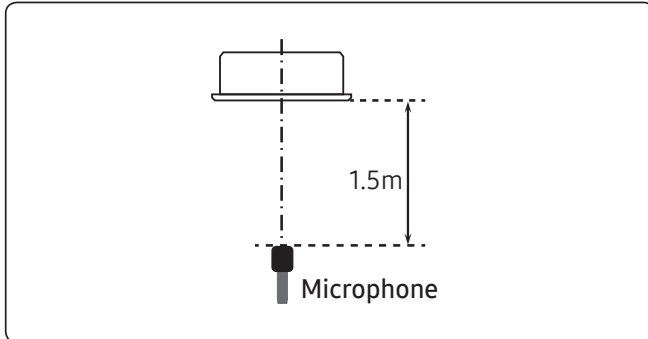

Model	High	MID	LOW
AM045DN6DKG/EU	33	31	29
AM056DN6DKG/EU	34	32	29
AM071DN6DKG/EU	36	33	30
AM090DN6DKG/EU	40	36	32

- NR Curve

1) AM045DN6DKG/EU

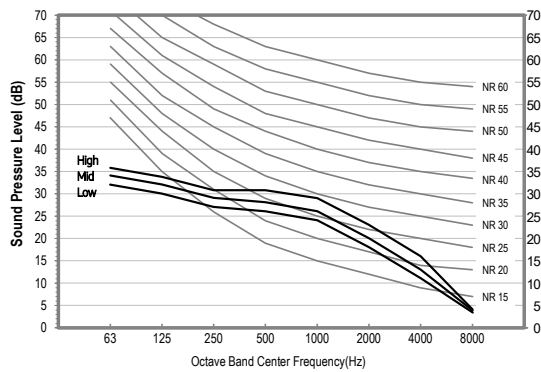

2) AM056DN6DKG/EU

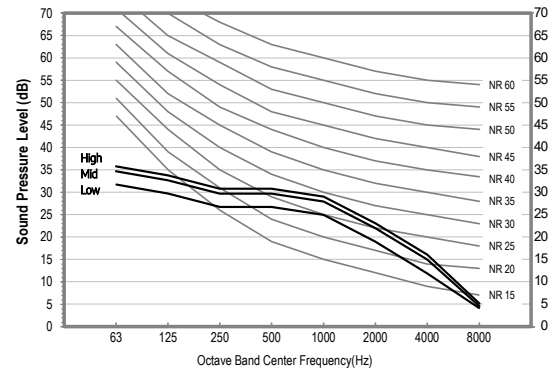

3) AM071DN6DKG/EU

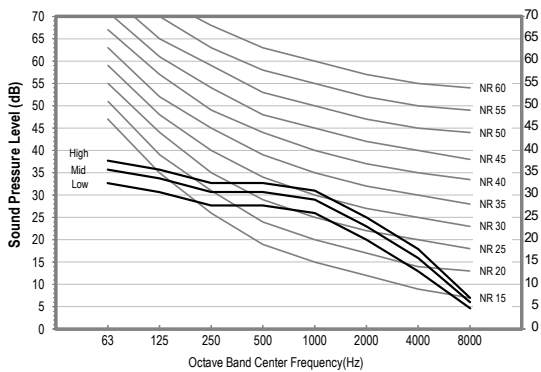

4) AM090DN6DKG/EU

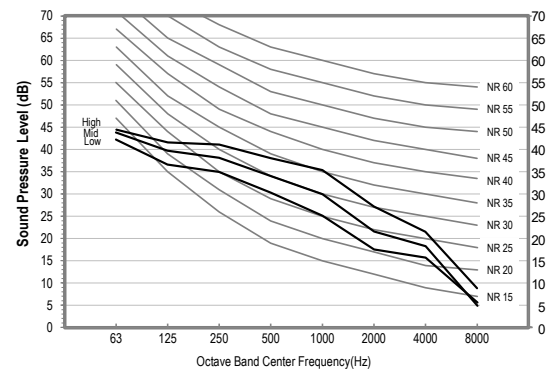

### NOTE

- Specifications may be subject to change without prior notice.
- Sound pressure Level
  - Sound pressure level is obtained in an anechoic room.
  - Sound pressure level is a relative value, depending on the distance and acoustic environment.
  - Sound pressure level may differ depending on operation condition.
  - dBA = A weighted sound pressure level
  - Reference acoustic pressure 0 dB = 20μPa

# 7. Sound Data

## 360 Cassette

### Sound Pressure level

Unit: dB(A)

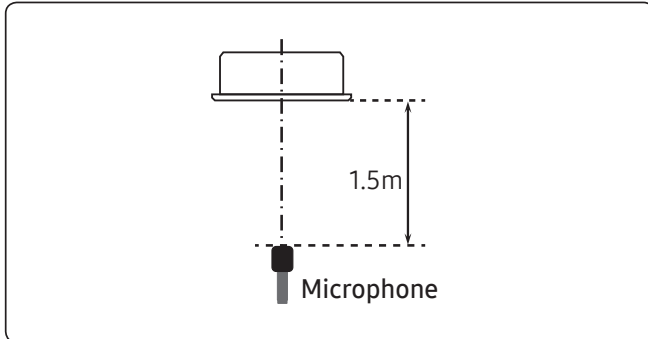

Model	High	MID	LOW
AM112DN6DKG/EU	40	36	32
AM128DN6DKG/EU	42	38	33
AM140DN6DKG/EU	44	40	35

- NR Curve

1) AM112DN6DKG/EU

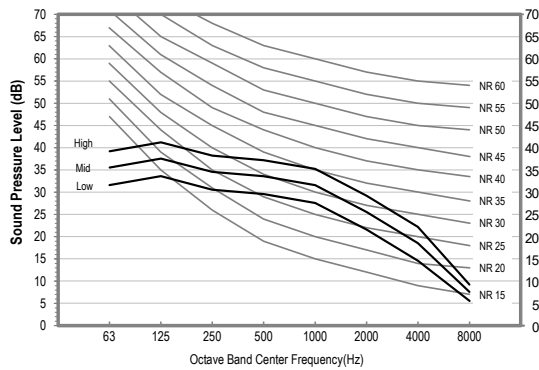

2) AM128DN6DKG/EU

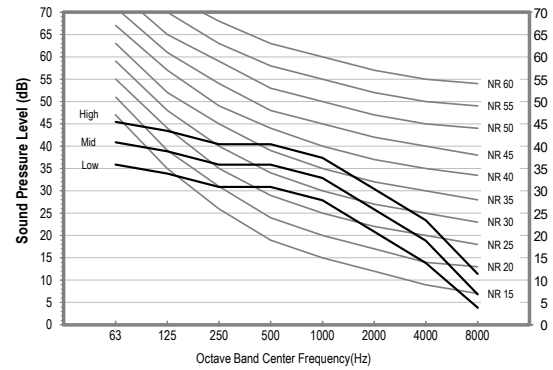

3) AM140DN6DKG/EU

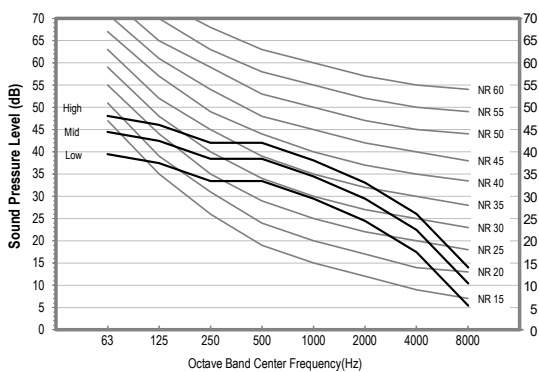

### NOTE

- Specifications may be subject to change without prior notice.
- Sound pressure Level
  - Sound pressure level is obtained in an anechoic room.
  - Sound pressure level is a relative value, depending on the distance and acoustic environment.
  - Sound pressure level may differ depending on operation condition.
  - dBA = A weighted sound pressure level
  - Reference acoustic pressure 0 dB = 20μPa

# 7. Sound Data

## 360 Cassette

### Sound Power level

#### NOTE

- Specifications may be subject to change without prior notice
  - Sound power level is an absolute value that a sound source generates.
  - dBA = A-weighted sound power level.
  - Reference power : 1pW.
  - Measured according to ISO 3741.

Unit: dB(A)

Model	Power
AM045DN6DKG/EU	50
AM056DN6DKG/EU	51
AM071DN6DKG/EU	53
AM090DN6DKG/EU	57

#### NR Curve

1) AM045DN6DKG/EU

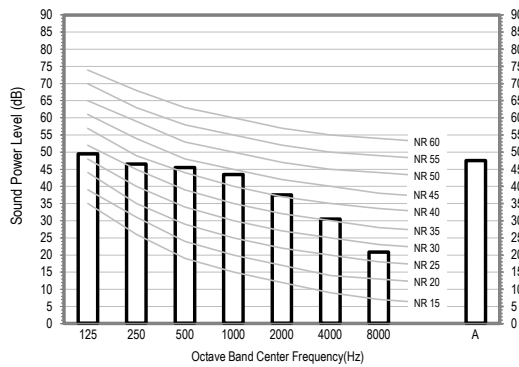

2) AM056DN6DKG/EU

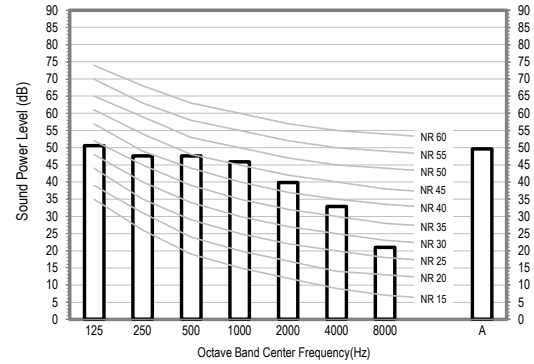

3) AM071DN6DKG/EU

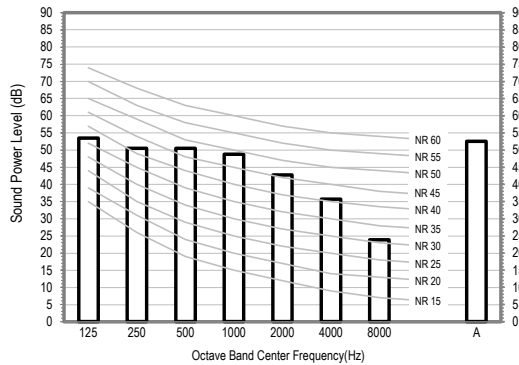

4) AM090DN6DKG/EU

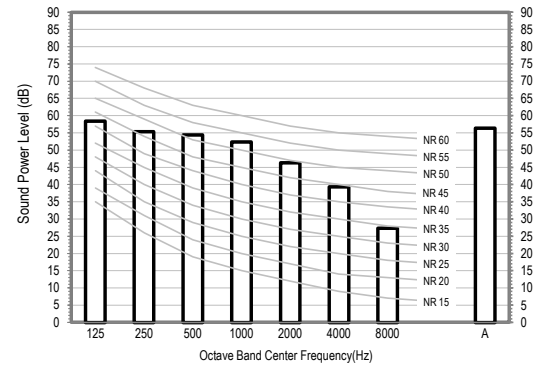

# 7. Sound Data

## 360 Cassette

### Sound Power level

#### NOTE

- Specifications may be subject to change without prior notice
  - Sound power level is an absolute value that a sound source generates.
  - dBA = A-weighted sound power level.
  - Reference power : 1pW.
  - Measured according to ISO 3741.

Unit: dB(A)

Model	Power
AM112DN6DKG/EU	58
AM128DN6DKG/EU	60
AM140DN6DKG/EU	61

#### • NR Curve

##### 1) AM112DN6DKG/EU

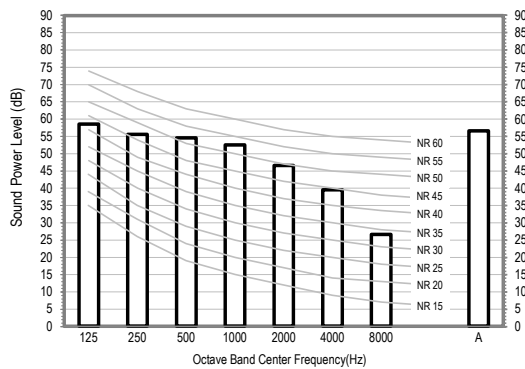

##### 2) AM128DN6DKG/EU

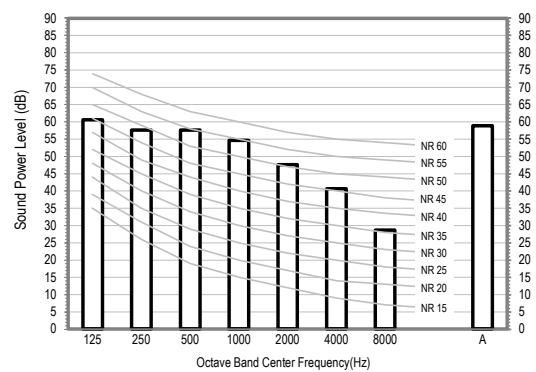

##### 3) AM140DN6DKG/EU

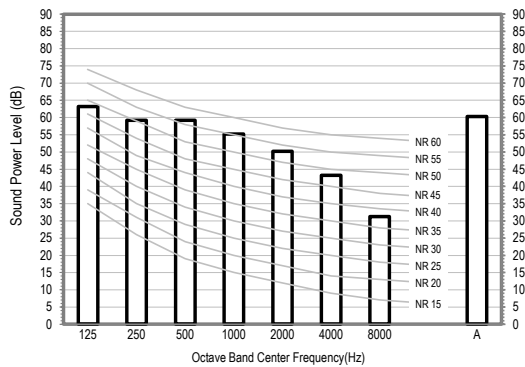

# 8. Temperature and air flow distribution

## 360 Cassette

### AM045DN6DKG/EU

- Cooling Air Velocity distribution

(Discharge angle : 60 degree)

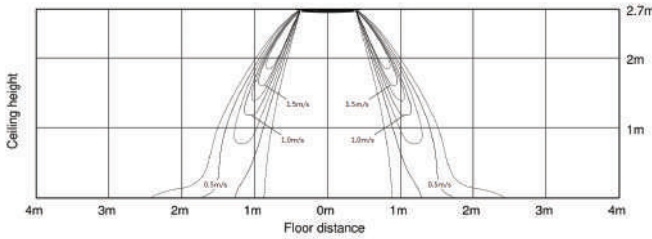

- Cooling temperature distribution

(Discharge angle : 60 degree)

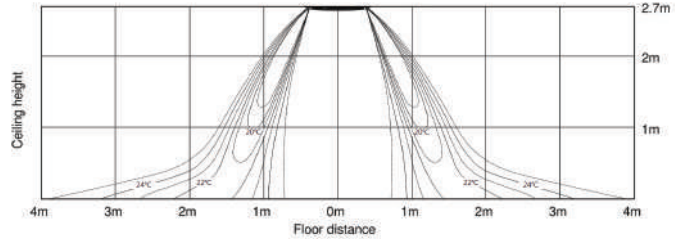

- Heating Air Velocity distribution

(Discharge angle : 60 degree)

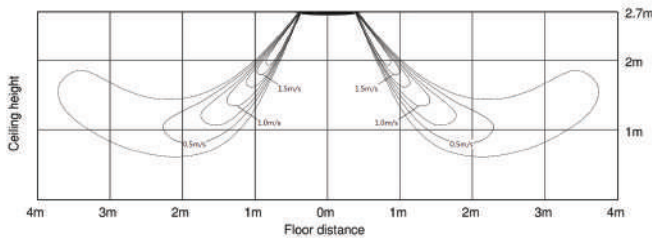

- Heating temperature distribution

(Discharge angle : 60 degree)

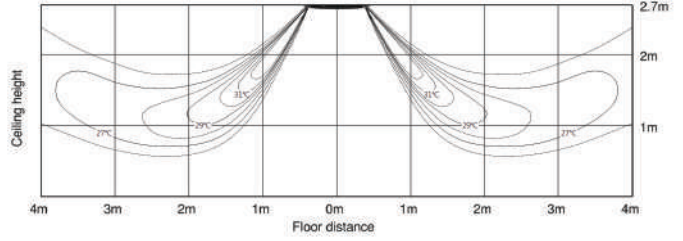

### AM056DN6DKG/EU

- Cooling Air Velocity distribution

(Discharge angle : 60 degree)

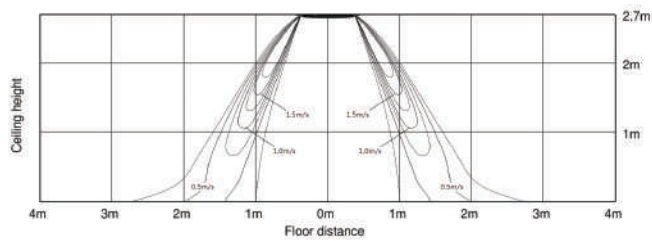

- Cooling temperature distribution

(Discharge angle : 60 degree)

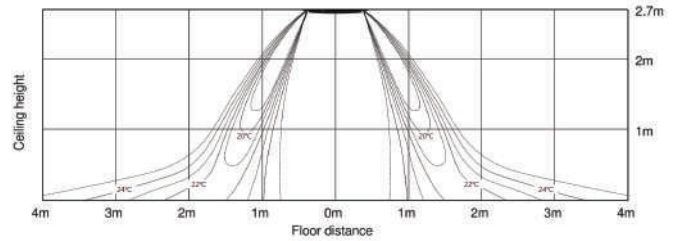

- Heating Air Velocity distribution

(Discharge angle : 60 degree)

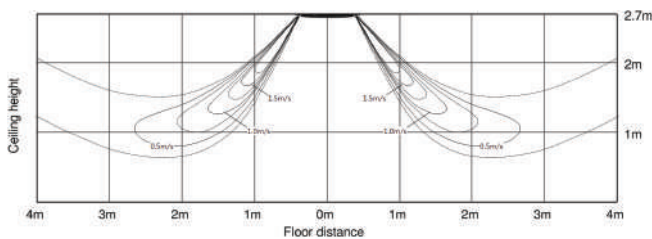

- Heating temperature distribution

(Discharge angle : 60 degree)

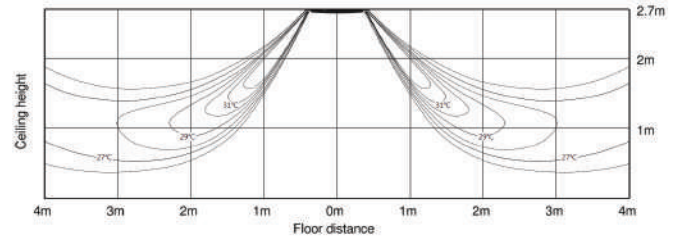

# 8. Temperature and air flow distribution

## 360 Cassette

### AM071DN6DKG/EU

- Cooling Air Velocity distribution

(Discharge angle : 60 degree)

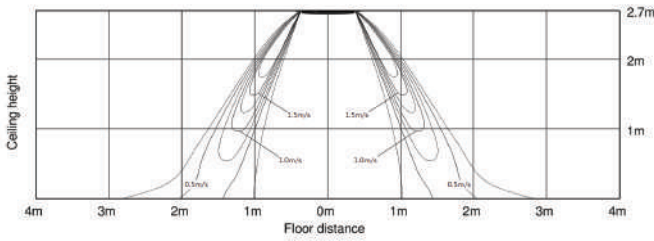

- Cooling temperature distribution

(Discharge angle : 60 degree)

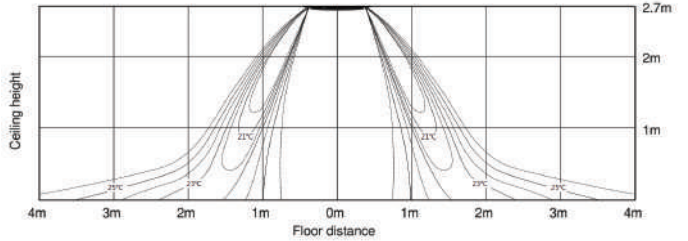

- Heating Air Velocity distribution

(Discharge angle : 60 degree)

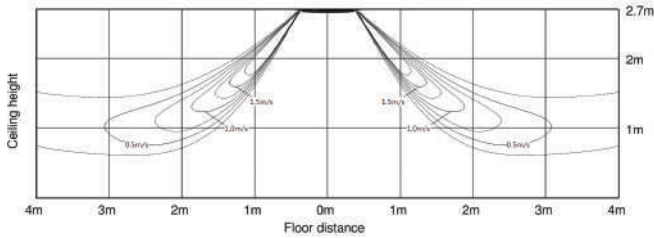

- Heating temperature distribution

(Discharge angle : 60 degree)

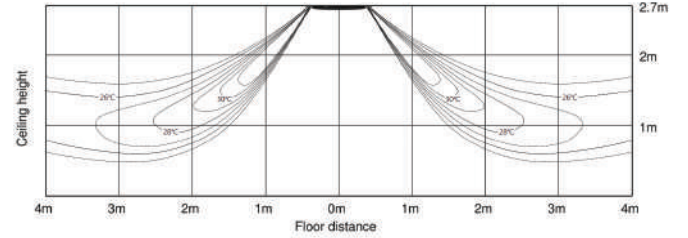

### AM090DN6DKG/EU

- Cooling Air Velocity distribution

(Discharge angle : 60 degree)

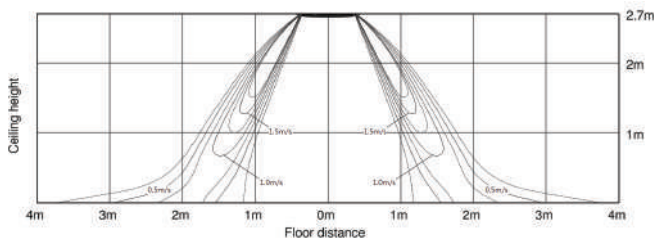

- Cooling temperature distribution

(Discharge angle : 60 degree)

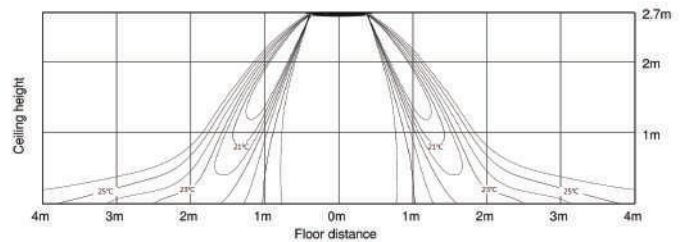

- Heating Air Velocity distribution

(Discharge angle : 60 degree)

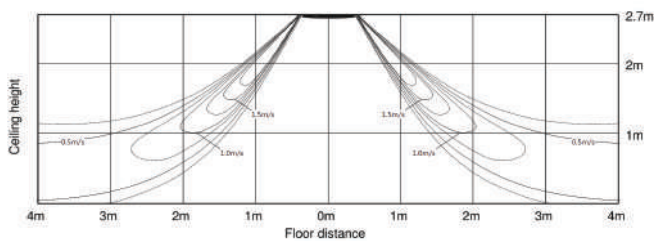

- Heating temperature distribution

(Discharge angle : 60 degree)

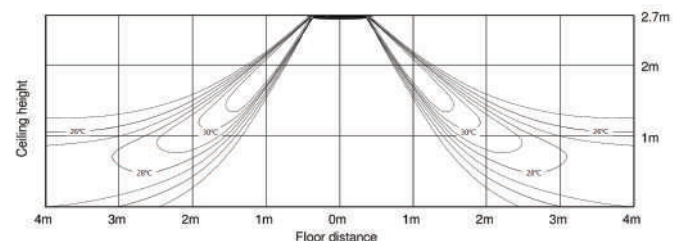

# 8. Temperature and air flow distribution

## 360 Cassette

### AM112DN6DKG/EU

- Cooling Air Velocity distribution

(Discharge angle : 60 degree)

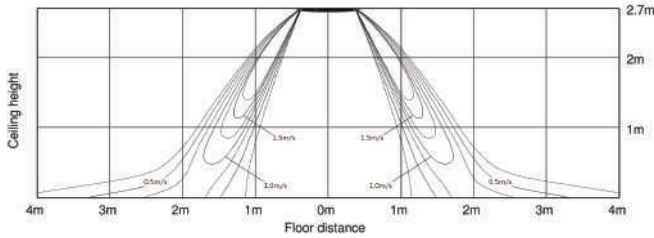

- Cooling temperature distribution

(Discharge angle : 60 degree)

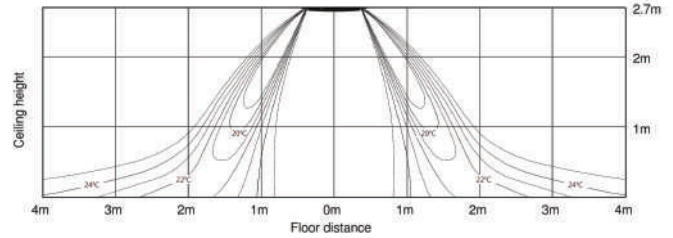

- Heating Air Velocity distribution

(Discharge angle : 60 degree)

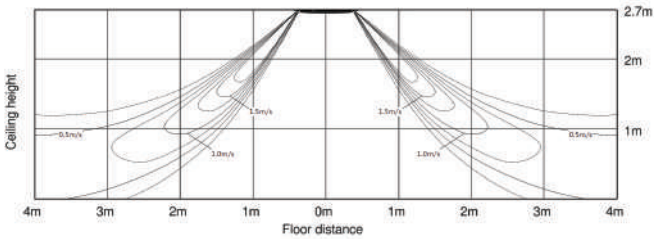

- Heating temperature distribution

(Discharge angle : 60 degree)

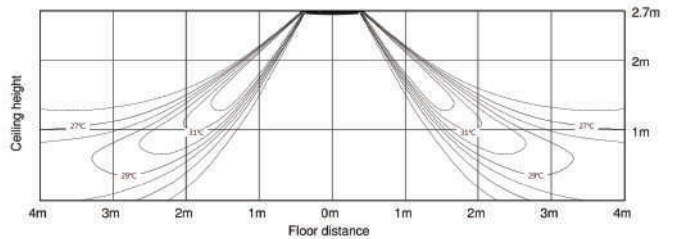

### AM128DN6DKG/EU

- Cooling Air Velocity distribution

(Discharge angle : 60 degree)

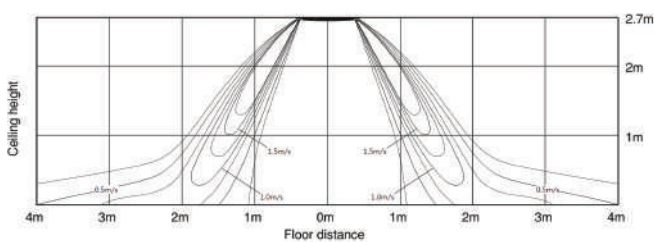

- Cooling temperature distribution

(Discharge angle : 60 degree)

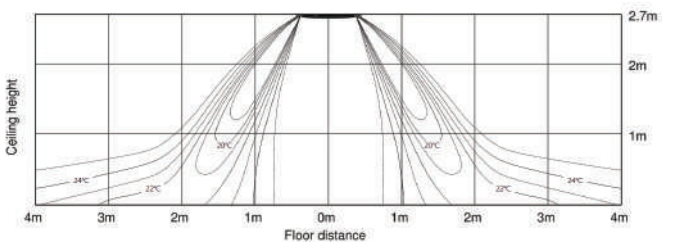

- Heating Air Velocity distribution

(Discharge angle : 60 degree)

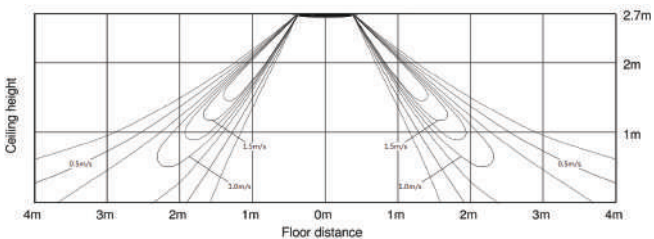

- Heating temperature distribution

(Discharge angle : 60 degree)

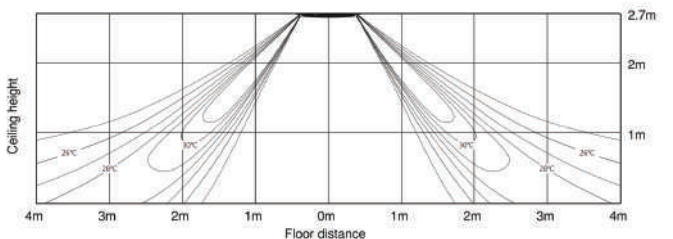

# 8. Temperature and air flow distribution

## 360 Cassette

### AM140DN6DKG/EU

- Cooling Air Velocity distribution

(Discharge angle : 60 degree)

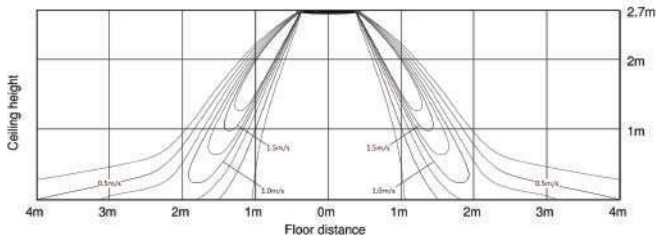

- Cooling temperature distribution

(Discharge angle : 60 degree)

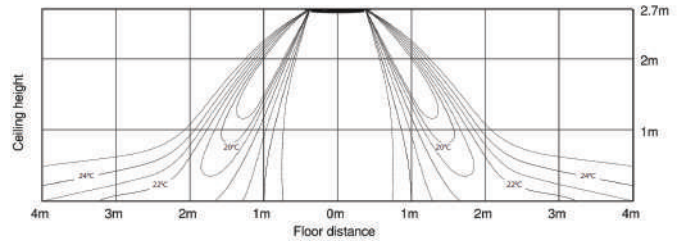

- Heating Air Velocity distribution

(Discharge angle : 60 degree)

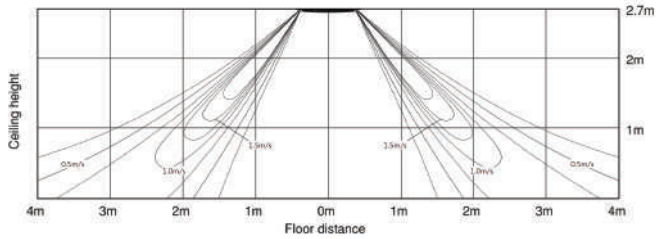

- Heating temperature distribution

(Discharge angle : 60 degree)

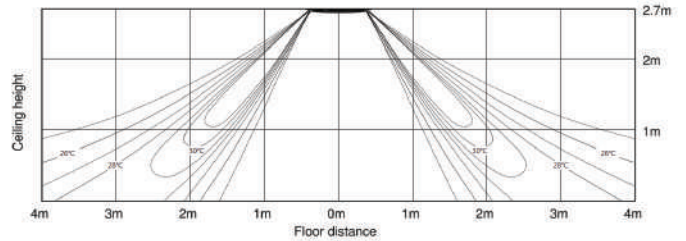

# 9. Piping Diagram

360 Cassette

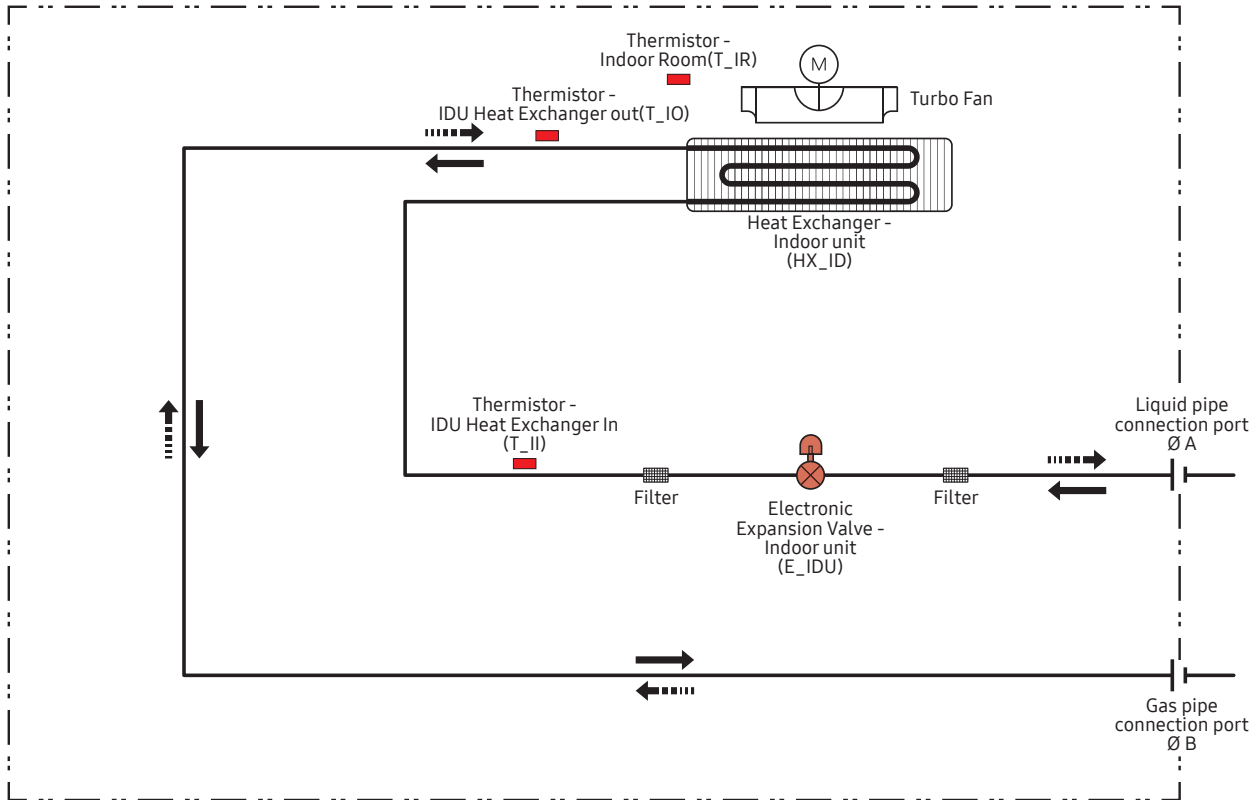

Refrigerant flow	
Cooling	Heating
→	→

# LSP Duct



---





<b>1. Specification</b>	<b>115</b>
<b>2. Summary Table</b>	<b>121</b>
<b>3. Capacity Table</b>	<b>123</b>
<b>4. Dimensional Drawing</b>	<b>124</b>
<b>5. Center of Gravity</b>	<b>130</b>
<b>6. Electrical Wiring Diagram</b>	<b>131</b>
<b>7. Sound Data</b>	<b>132</b>
<b>8. Fan Characteristics</b>	<b>140</b>
<b>9. Piping Diagram</b>	<b>150</b>

---

# Line-up

## LSP Duct

Capacity (kW)						
AM017HELDKG	AM022HELDKG	AM028HELDKG	AM036HELDKG	AM045HELDKG	AM056HELDKG	AM071HELDKG
						

Capacity (kW)						
AM017DNLDKG	AM022DNLDKG	AM028DNLDKG	AM036DNLDKG	AM045DNLDKG	AM056DNLDKG	AM071DNLDKG
						

# 1. Specification

## LSP Duct

Model Name			AM017HELDKG/EU	AM022HELDKG/EU	AM028HELDKG/EU	
Power Supply			Φ, #, V, Hz	1,2,220-240,50/60	1,2,220-240,50/60	1,2,220-240,50/60
Performance	Capacity	Cooling	kW	1.7	2.2	2.8
			Btu/h	5,800	7,500	9,600
		Heating	kW	1.9	2.5	3.2
			Btu/h	6,500	8,500	10,900
Power	Power Input	Cooling	W	28.0	30.0	34.0
		Heating		28.0	30.0	36.0
	Current Input	Cooling	A	0.23	0.25	0.28
		Heating		0.23	0.25	0.30
	Current	MCA	A	0.35	0.38	0.45
		MFA		15.00	15.00	15.00
Heat exchanger	Type		-	Fin & Tube	Fin & Tube	Fin & Tube
	Material	Fin	-	Al	Al	Al
		Tube	-	Cu	Cu	Cu
	Fin Treatment		-	hydrophilic	hydrophilic	hydrophilic
Fan	Type	Type	-	Sirocco Fan	Sirocco Fan	Sirocco Fan
	Quantity		ea	2	2	2
	Air Flow Rate	H/M/L	CMM	5.5 / 4.5 / 3.8	6.0 / 4.9 / 3.8	7.1 / 5.2 / 4.4
			l/s	91 / 74 / 63	100 / 82 / 63	118 / 86 / 73
	External Pressure	Min/Std/Max	mmAq	0.0 / 1.0 / 3.0	0.0 / 1.0 / 3.0	0.0 / 1.0 / 3.0
			Pa	0.00 / 9.81 / 29.42	0.00 / 9.81 / 29.42	0.00 / 9.81 / 29.42
Fan Motor	Model		-	BLDC	BLDC	BLDC
	Output x n		W	69	69	69
Piping Connections	Liquid Pipe		Type	Flare connection	Flare connection	Flare connection
			Φ, mm (inch)	6.35 (1/4)	6.35 (1/4)	6.35 (1/4)
	Gas Pipe		Type	Flare connection	Flare connection	Flare connection
			Φ, mm (inch)	12.7 (1/2)	12.7 (1/2)	12.7 (1/2)
	Heat insulation		-	Both liquid & gas pipes	Both liquid & gas pipes	Both liquid & gas pipes
Drain Pipe		Φ,mm	VP25 (OD 32, ID 25)	VP25 (OD 32, ID 25)	VP25 (OD 32, ID 25)	
Wiring connections	Communication	Min.	mm <sup>2</sup>	0.75	0.75	0.75
		Remark	-	F1, F2	F1, F2	F1, F2
Refrigerant	Type		-	R32	R32	R32
	Electronic Expansion Valve		-	EEV INCLUDED	EEV INCLUDED	EEV INCLUDED
Sound Level	Sound Pressure Level	H/M/L	dB(A)	25 / 22 / 19	26 / 23 / 19	28 / 24 / 19
	Sound Power Level	Cooling		40	42	44
Dimensions	Net Weight		kg	15.9	15.9	15.9
	Shipping Weight		kg	19.2	19.2	19.2
	Net Dimensions (W×H×D)		mm	700 x 199 x 440	700 x 199 x 440	700 x 199 x 440
	Shipping Dimensions (W×H×D)		mm	949 x 280 x 544	949 x 280 x 544	949 x 280 x 544
Casing	Material		-	Steel	Steel	Steel
Additional Accessories	Drain Pump		-	MDP-Z075SZED	MDP-Z075SZED	MDP-Z075SZED
	Max. lifting Height / Displacement		mm / Liter/h	750 / 24	750 / 24	750 / 24
	Air Filter		-	-	-	-

### NOTE

- Specification may be subject to change without prior notice.
  - 1) Capacities are based on (Equivalent refrigerant piping 7.5m, Level differences 0m);
    - Cooling : Indoor temperature 27°C DB, 19°C WB / Outdoor temperature 35°C DB, 24°C WB
    - Heating : Indoor temperature 20°C DB, 15°C WB / Outdoor temperature 7°C DB, 6°C WB
  - 2) Sound level was acquired in an anechoic room. Thus actual noise level may be different depending on the installation conditions.
  - 3) These products contain R32 (GWP=675) which is fluorinated greenhouse gas.
  - 4) Select wire size based on the value of MCA

# 1. Specification

## LSP Duct

Model Name			AM036HELDKG/EU	AM045HELDKG/EU	AM056HELDKG/EU
Power Supply			Φ, #, V, Hz	1,2,220-240,50/60	1,2,220-240,50/60
Performance	Capacity	Cooling	kW	3.6	4.5
			Btu/h	12,300	15,400
		Heating	kW	4.0	5.0
			Btu/h	13,600	17,100
Power	Power Input	Cooling	W	40.0	51.0
		Heating		42.0	46.0
	Current Input	Cooling	A	0.33	0.45
		Heating		0.35	0.41
	Current	MCA	A	0.53	0.64
		MFA		15.00	15.00
Heat exchanger	Type		-	Fin & Tube	Fin & Tube
	Material	Fin	-	Al	Al
		Tube	-	Cu	Cu
	Fin Treatment		-	hydrophilic	hydrophilic
Fan	Type	Type	-	Sirocco Fan	Sirocco Fan
	Quantity		ea	2	2
	Air Flow Rate	H/M/L	CMM	8.2 / 6.5 / 4.9	12.5 / 10.0 / 7.5
			l/s	137 / 108 / 82	208 / 167 / 125
	External Pressure	Min/Std/Max	mmAq	0.0 / 1.0 / 3.0	0.0 / 2.0 / 4.0
			Pa	0.00 / 9.81 / 29.42	0.00 / 19.61 / 39.23
Fan Motor	Model		-	BLDC	BLDC
	Output x n		W	69	84
Piping Connections	Liquid Pipe		Type	Flare connection	Flare connection
			Φ, mm (inch)	6.35 (1/4)	6.35 (1/4)
	Gas Pipe		Type	Flare connection	Flare connection
			Φ, mm (inch)	12.7 (1/2)	12.7 (1/2)
	Heat insulation		-	Both liquid & gas pipes	Both liquid & gas pipes
Drain Pipe		Φ,mm	VP25 (OD 32, ID 25)	VP25 (OD 32, ID 25)	
Wiring connections	Communication	Min.	mm <sup>2</sup>	0.75	0.75
		Remark	-	F1, F2	F1, F2
Refrigerant	Type		-	R32	R32
	Electronic Expansion Valve		-	EEV INCLUDED	EEV INCLUDED
Sound Level	Sound Pressure Level	H/M/L	dB(A)	31 / 26 / 20	32 / 28 / 25
	Sound Power Level	Cooling		46	47
Dimensions	Net Weight		kg	16.3	19.3
	Shipping Weight		kg	19.6	22.8
	Net Dimensions (W×H×D)		mm	700 x 199 x 440	900 x 199 x 440
	Shipping Dimensions (W×H×D)		mm	949 x 280 x 544	1,151 x 280 x 544
Casing	Material		-	Steel	Steel
Additional Accessories	Drain Pump		-	MDP-Z075SZED	MDP-Z075SZED
	Max. lifting Height / Displacement		mm / Liter/h	750 / 24	750 / 24
	Air Filter		-	-	-

### NOTE

- Specification may be subject to change without prior notice.
  - 1) Capacities are based on (Equivalent refrigerant piping 7.5m, Level differences 0m);
    - Cooling : Indoor temperature 27°C DB, 19°C WB / Outdoor temperature 35°C DB, 24°C WB
    - Heating : Indoor temperature 20°C DB, 15°C WB / Outdoor temperature 7°C DB, 6°C WB
  - 2) Sound level was acquired in an anechoic room. Thus actual noise level may be different depending on the installation conditions.
  - 3) These products contain R32 (GWP=675) which is fluorinated greenhouse gas.
  - 4) Select wire size based on the value of MCA

# 1. Specification

## LSP Duct

Model Name			AM071HELDKG/EU	
Power Supply			Φ, #, V, Hz	
			1,2,220-240,50/60	
Performance	Capacity	Cooling	kW	
			7.1	
		Heating	Btu/h	
			24,200	
		kW		
		8.0		
		Btu/h		
		27,300		
Power	Power Input	Cooling	W	82.0
		Heating		77.0
	Current Input	Cooling	A	0.69
		Heating		0.65
	Current	MCA	A	1.04
		MFA		15.00
Heat exchanger	Type		-	
			Fin & Tube	
	Material	Fin	-	
		Tube	-	
Fin Treatment		-		
		hydrophilic		
Fan	Type	Type	-	
			Sirocco Fan	
	Quantity		ea	
			3	
	Air Flow Rate	H/M/L	CMM	
			18.0 / 14.5 / 11.0	
		l/s		
		300 / 242 / 183		
External Pressure	Min/Std/Max	mmAq		
		0.0 / 2.0 / 4.0		
		Pa		
		0.00 / 19.61 / 39.23		
Fan Motor	Model		-	
			BLDC	
Output x n		W		
		84		
Piping Connections	Liquid Pipe		Type	Flare connection
			Φ, mm (inch)	9.52 (3/8)
	Gas Pipe		Type	Flare connection
			Φ, mm (inch)	15.88 (5/8)
	Heat insulation		-	
		Both liquid & gas pipes		
Drain Pipe			Φ,mm	VP25 (OD 32, ID 25)
Wiring connections	Communication	Min.	mm <sup>2</sup>	
				0.75
		Remark	-	
				F1, F2
Refrigerant	Type		-	
			R32	
Electronic Expansion Valve		-		EEV INCLUDED
Sound Level	Sound Pressure Level	H/M/L	dB(A)	
Sound Power Level		Cooling	49	
Dimensions	Net Weight		kg	22.7
	Shipping Weight		kg	26.4
	Net Dimensions (W×H×D)		mm	1,100 x 199 x 440
	Shipping Dimensions (W×H×D)		mm	1,351 x 280 x 544
Casing	Material		-	
				Steel
Additional Accessories	Drain Pump		-	
			MDP-E075SEE3D	
	Max. lifting Height / Displacement		mm / Liter/h	750 / 24
Air Filter		-		-

### NOTE

- Specification may be subject to change without prior notice.
  - 1) Capacities are based on (Equivalent refrigerant piping 7.5m, Level differences 0m);
    - Cooling : Indoor temperature 27°C DB, 19°C WB / Outdoor temperature 35°C DB, 24°C WB
    - Heating : Indoor temperature 20°C DB, 15°C WB / Outdoor temperature 7°C DB, 6°C WB
  - 2) Sound level was acquired in an anechoic room. Thus actual noise level may be different depending on the installation conditions.
  - 3) These products contain R32 (GWP=675) which is fluorinated greenhouse gas.
  - 4) Select wire size based on the value of MCA

# 1. Specification

## LSP Duct

Model Name				AM017DNLDKG/EU	AM022DNLDKG/EU	AM028DNLDKG/EU
Power Supply			Φ, #, V, Hz	1,2,220~240,50/60	1,2,220~240,50/60	1,2,220~240,50/60
Performance	Capacity	Cooling	kW	1.7	2.2	2.8
			Btu/h	5,800	7,500	9,600
	Heating	kW	1.9	2.5	3.2	
		Btu/h	6,500	8,500	10,900	
Power	Power Input	Cooling	W	28.0	30.0	34.0
		Heating		28.0	30.0	36.0
	Current Input	Cooling	A	0.23	0.25	0.28
		Heating		0.23	0.25	0.30
	Current	MCA	A	0.35	0.38	0.45
		MFA		15	15	15
Heat exchanger	Type		-	Fin & Tube	Fin & Tube	Fin & Tube
	Material	Fin	-	Al	Al	Al
		Tube	-	Cu	Cu	Cu
	Fin Treatment		-	hydrophilic	hydrophilic	hydrophilic
Fan	Type		-	Sirocco Fan	Sirocco Fan	Sirocco Fan
	Quantity		EA	2	2	2
	Air Flow Rate	H/M/L	m <sup>3</sup> /min	5.45 / 4.45 / 3.8	6 / 4.9 / 3.8	7.05 / 5.15 / 4.35
			l/s	91 / 74 / 63	100 / 82 / 63	118 / 86 / 73
	External Pressure	Min/Std/Max	mmAq	0 / 1 / 3	0 / 1 / 3	0 / 1 / 3
			Pa	0 / 9.81 / 29.42	0 / 9.81 / 29.42	0 / 9.81 / 29.42
Fan Motor	Type		-	BLDC	BLDC	BLDC
	Output x n		W	69	69	69
Piping Connections	Liquid Pipe		Type	Flare connection	Flare connection	Flare connection
			Φ, mm (inch)	6.35 (1/4)	6.35 (1/4)	6.35 (1/4)
	Gas Pipe		Type	Flare connection	Flare connection	Flare connection
			Φ, mm (inch)	12.7 (1/2)	12.7 (1/2)	12.7 (1/2)
Drain Pipe		Φ, inch	VP25 (OD 32, ID 25)	VP25 (OD 32, ID 25)	VP25 (OD 32, ID 25)	
Wiring connections	Communication (Min.)		mm <sup>2</sup>	0.75	0.75	0.75
			-	F1, F2	F1, F2	F1, F2
Refrigerant	Type		-	R32	R32	R32
	Control Method		-	EEV	EEV	EEV
Sound	Sound Pressure Level	H/M/L	dB(A)	25 / 22 / 19	26 / 23 / 19	28 / 24 / 19
		Cooling		40	42	44
External Dimension	Net Weight		kg	15.9	15.9	15.9
	Shipping Weight		kg	19.2	19.2	19.2
	Net Dimensions (W×H×D)		mm	700 x 199 x 440	700 x 199 x 440	700 x 199 x 440
	Shipping Dimensions (W×H×D)		mm	949 x 280 x 544	949 x 280 x 544	949 x 280 x 544
Casing	Material		-	Steel	Steel	Steel
Additional Accessories	Drain pump	External Model	-	-	-	-
		Internal Model	-	Built in	Built in	Built in
		Max. lifting	mm / Liter/h	750 / 24	750 / 24	750 / 24
	Air Filter		-	-	-	-

### NOTE

- Specification may be subject to change without prior notice.
  - 1) Capacities are based on (Equivalent refrigerant piping 7.5m, Level differences 0m);
    - Cooling : Indoor temperature 27°C DB, 19°C WB / Outdoor temperature 35°C DB, 24°C WB
    - Heating : Indoor temperature 20°C DB, 15°C WB / Outdoor temperature 7°C DB, 6°C WB
  - 2) Sound level was acquired in an anechoic room. Thus actual noise level may be different depending on the installation conditions.
  - 3) These products contain R32 (GWP=675) which is fluorinated greenhouse gas.
  - 4) Select wire size based on the value of MCA

# 1. Specification

## LSP Duct

Model Name				AM036DNLDKG/EU	AM045DNLDKG/EU	AM056DNLDKG/EU
Power Supply			Φ, #, V, Hz	1,2,220~240,50/60	1,2,220~240,50/60	1,2,220~240,50/60
Performance	Capacity	Cooling	kW	3.6	4.5	5.6
			Btu/h	12,300	15,400	19,100
	Heating	kW	4.0	5.0	6.3	
		Btu/h	13,600	17,100	21,500	
Power	Power Input	Cooling	W	40.0	51.0	73.0
		Heating		42.0	46.0	68.0
	Current Input	Cooling	A	0.33	0.50	0.62
		Heating		0.35	0.40	0.58
	Current	MCA	A	0.53	0.64	0.92
		MFA		15	15	15
Heat exchanger	Type		-	Fin & Tube	Fin & Tube	Fin & Tube
	Material	Fin	-	Al	Al	Al
		Tube	-	Cu	Cu	Cu
	Fin Treatment		-	hydrophilic	hydrophilic	hydrophilic
Fan	Type		-	Sirocco Fan	Sirocco Fan	Sirocco Fan
	Quantity		EA	2	2	2
	Air Flow Rate	H/M/L	m <sup>3</sup> /min	8.2 / 6.5 / 4.9	12.5 / 10 / 7.5	15.5 / 12.5 / 9.5
			l/s	137 / 108 / 82	208 / 167 / 125	258 / 208 / 158
	External Pressure	Min/Std/Max	mmAq	0 / 1 / 3	0 / 2 / 4	0 / 2 / 4
			Pa	0 / 9.81 / 29.42	0 / 19.61 / 39.23	0 / 19.61 / 39.23
Fan Motor	Type		-	BLDC	BLDC	BLDC
	Output x n		W	69	84	84
Piping Connections	Liquid Pipe		Type	Flare connection	Flare connection	Flare connection
			Φ, mm (inch)	6.35 (1/4)	6.35 (1/4)	6.35 (1/4)
	Gas Pipe		Type	Flare connection	Flare connection	Flare connection
			Φ, mm (inch)	12.7 (1/2)	12.7 (1/2)	12.7 (1/2)
Drain Pipe		Φ,inch	VP25 (OD 32,ID 25)	VP25 (OD 32,ID 25)	VP25 (OD 32,ID 25)	
Wiring connections	Communication (Min.)		mm <sup>2</sup>	0.75	0.75	0.75
			-	F1, F2	F1, F2	F1, F2
Refrigerant	Type		-	R32	R32	R32
	Control Method		-	EEV	EEV	EEV
Sound	Sound Pressure Level	H/M/L	dB(A)	31 / 26 / 20	32 / 28 / 25	34 / 30 / 26
		Cooling		46	47	49
External Dimension	Net Weight		kg	16.3	19.3	19.3
	Shipping Weight		kg	19.6	22.8	22.8
	Net Dimensions (W×H×D)		mm	700 x 199 x 440	900 x 199 x 440	900 x 199 x 440
	Shipping Dimensions (W×H×D)		mm	949 x 280 x 544	1,151 x 280 x 544	1,151 x 280 x 544
Casing	Material		-	Steel	Steel	Steel
Additional Accessories	Drain pump	External Model	-	-	-	-
		Internal Model	-	Built in	Built in	Built in
		Max. lifting	mm / Liter/h	750 / 24	750 / 24	750 / 24
	Air Filter		-	-	-	-

### NOTE

- Specification may be subject to change without prior notice.
  - 1) Capacities are based on (Equivalent refrigerant piping 7.5m, Level differences 0m);
    - Cooling : Indoor temperature 27°C DB, 19°C WB / Outdoor temperature 35°C DB, 24°C WB
    - Heating : Indoor temperature 20°C DB, 15°C WB / Outdoor temperature 7°C DB, 6°C WB
  - 2) Sound level was acquired in an anechoic room. Thus actual noise level may be different depending on the installation conditions.
  - 3) These products contain R32 (GWP=675) which is fluorinated greenhouse gas.
  - 4) Select wire size based on the value of MCA

# 1. Specification

## LSP Duct

Model Name			AM071DNLDKG/EU	
Power Supply			Φ, #, V, Hz	
			1,2,220~240,50/60	
Performance	Capacity	Cooling	kW	7.1
			Btu/h	24,200
	Heating	kW	8.0	
		Btu/h	27,300	
Power	Power Input	Cooling	W	82.0
		Heating		77.0
	Current Input	Cooling	A	0.69
		Heating		0.65
	Current	MCA	A	1.04
		MFA		15
Heat exchanger	Type		-	Fin & Tube
	Material	Fin	-	Al
		Tube	-	Cu
	Fin Treatment		-	hydrophilic
Fan	Type		-	Sirocco Fan
	Quantity		EA	3
	Air Flow Rate	H/M/L	m <sup>3</sup> /min	18 / 14.5 / 11
			l/s	300 / 242 / 183
	External Pressure	Min/Std/Max	mmAq	0 / 2 / 4
			Pa	0 / 19.61 / 39.23
Fan Motor	Type		-	BLDC
	Output x n		W	84
Piping Connections	Liquid Pipe		Type	Flare connection
			Φ, mm (inch)	9.52 (3/8)
	Gas Pipe		Type	Flare connection
			Φ, mm (inch)	15.88 (5/8)
	Drain Pipe		Φ, inch	VP25 (OD 32, ID 25)
Wiring connections	Communication (Min.)		mm <sup>2</sup>	0.75
			-	F1, F2
Refrigerant	Type		-	R32
	Control Method		-	EEV
Sound	Sound Pressure Level	H/M/L	dB(A)	34 / 30 / 27
		Cooling		49
External Dimension	Net Weight		kg	22.7
	Shipping Weight		kg	26.4
	Net Dimensions (W×H×D)		mm	1,100 x 199 x 440
	Shipping Dimensions (W×H×D)		mm	1,351 x 280 x 544
Casing	Material		-	Steel
Additional Accessories	Drain pump	External Model	-	-
		Internal Model	-	Built in
		Max. lifting	mm / Liter/h	750 / 24
	Air Filter		-	-

### NOTE

- Specification may be subject to change without prior notice.
  - 1) Capacities are based on (Equivalent refrigerant piping 7.5m, Level differences 0m);
    - Cooling : Indoor temperature 27°C DB, 19°C WB / Outdoor temperature 35°C DB, 24°C WB
    - Heating : Indoor temperature 20°C DB, 15°C WB / Outdoor temperature 7°C DB, 6°C WB
  - 2) Sound level was acquired in an anechoic room. Thus actual noise level may be different depending on the installation conditions.
  - 3) These products contain R32 (GWP=675) which is fluorinated greenhouse gas.
  - 4) Select wire size based on the value of MCA

## 2. Summary Table

### LSP Duct

#### Performance Characteristics

Model Code	Fan Speed	Nominal Capacity [kW]			Airflow [CMM]	Sound Pressure [dBA]	Sound Power [dBA]	Static Pressure (Min/Std/Max) [mmAq]
		Cooling	Sensible	Heating				
AM017HELDKG/EU	High	1.7	1.3	1.9	5.50	25	40	0 / 1 / 3
	Mid	1.4	1.1	1.7	4.50	22	-	
	Low	1.2	0.9	1.6	3.80	19	-	
AM022HELDKG/EU	High	2.2	1.6	2.5	6.00	26	42	0 / 1 / 3
	Mid	1.8	1.3	2.3	4.90	23	-	
	Low	1.4	1.0	2.0	3.80	19	-	
AM028HELDKG/EU	High	2.8	2.0	3.2	7.05	28	44	0 / 1 / 3
	Mid	2.1	1.5	2.7	5.15	24	-	
	Low	1.8	1.3	2.5	4.35	19	-	
AM036HELDKG/EU	High	3.6	2.6	4.0	8.20	31	46	0 / 1 / 3
	Mid	2.9	2.1	3.6	6.50	26	-	
	Low	2.2	1.6	3.1	4.90	20	-	
AM045HELDKG/EU	High	4.5	3.3	5.0	12.50	32	47	0 / 2 / 4
	Mid	3.7	2.7	4.5	10.00	28	-	
	Low	2.8	2.1	3.9	7.50	25	-	
AM056HELDKG/EU	High	5.6	4.2	6.3	15.50	34	49	0 / 2 / 4
	Mid	4.6	3.5	5.7	12.50	30	-	
	Low	3.5	2.6	4.9	9.50	26	-	
AM071HELDKG/EU	High	7.1	5.4	8.0	18.00	34	49	0 / 2 / 4
	Mid	5.9	4.5	7.2	14.50	30	-	
	Low	4.5	3.4	6.3	11.00	27	-	

#### NOTE

- Sound data is based on cooling operation.

#### Electrical Characteristics

Model Code	Power Supply (Φ, #, V, Hz)	Power Input (W)	Current Input (A)	MCA (A)	MFA (A)	FLA (A)
AM017HELDKG/EU	1,2,220~240,50/60	28	0.23	0.35	15	0.28
AM022HELDKG/EU		30	0.25	0.38	15	0.30
AM028HELDKG/EU		34	0.28	0.45	15	0.36
AM036HELDKG/EU		40	0.33	0.53	15	0.42
AM045HELDKG/EU		51	0.45	0.64	15	0.51
AM056HELDKG/EU		73	0.62	0.92	15	0.74
AM071HELDKG/EU		82	0.69	1.04	15	0.83

#### NOTE

- MCA: Minimum circuit amperes
- MFA: Maximum fuse amperes
- FLA: Full load amperes
- Select wire size based on the value of MCA

## 2. Summary Table

### LSP Duct

#### Performance Characteristics

Model Code	Fan Speed	Nominal Capacity [kW]			Airflow [CMM]	Sound Pressure [dBA]	Sound Power [dBA]	Static Pressure (Min/Std/Max) [mmAq]
		Cooling	Sensible	Heating				
AM017DNLDKG/EU	High	1.7	1.3	1.9	5.50	25	40	0 / 1 / 3
	Mid	1.4	1.1	1.7	4.50	22	-	
	Low	1.2	0.9	1.6	3.80	19	-	
AM022DNLDKG/EU	High	2.2	1.6	2.5	6.00	26	42	0 / 1 / 3
	Mid	1.8	1.3	2.3	4.90	23	-	
	Low	1.4	1.0	2.0	3.80	19	-	
AM028DNLDKG/EU	High	2.8	2.0	3.2	7.05	28	44	0 / 1 / 3
	Mid	2.1	1.5	2.7	5.15	24	-	
	Low	1.8	1.3	2.5	4.35	19	-	
AM036DNLDKG/EU	High	3.6	2.6	4.0	8.20	31	46	0 / 1 / 3
	Mid	2.9	2.1	3.6	6.50	26	-	
	Low	2.2	1.6	3.1	4.90	20	-	
AM045DNLDKG/EU	High	4.5	3.3	5.0	12.50	32	47	0 / 2 / 4
	Mid	3.7	2.7	4.5	10.00	28	-	
	Low	2.8	2.1	3.9	7.50	25	-	
AM056DNLDKG/EU	High	5.6	4.2	6.3	15.50	34	49	0 / 2 / 4
	Mid	4.6	3.5	5.7	12.50	30	-	
	Low	3.5	2.6	4.9	9.50	26	-	
AM071DNLDKG/EU	High	7.1	5.4	8.0	18.00	34	49	0 / 2 / 4
	Mid	5.9	4.5	7.2	14.50	30	-	
	Low	4.5	3.4	6.3	11.00	27	-	

#### NOTE

- Sound data is based on cooling operation.

#### Electrical Characteristics

Model Code	Power Supply (Φ, #, V, Hz)	Power Input (W)	Current Input (A)	MCA (A)	MFA (A)	FLA (A)
AM017DNLDKG/EU	1,2,220~240,50/60	28	0.23	0.35	15	0.28
AM022DNLDKG/EU		30	0.25	0.38	15	0.30
AM028DNLDKG/EU		34	0.28	0.45	15	0.36
AM036DNLDKG/EU		40	0.33	0.53	15	0.42
AM045DNLDKG/EU		51	0.45	0.64	15	0.51
AM056DNLDKG/EU		73	0.62	0.92	15	0.74
AM071DNLDKG/EU		82	0.69	1.04	15	0.83

#### NOTE

- MCA: Minimum circuit amperes
- MFA: Maximum fuse amperes
- FLA: Full load amperes
- Select wire size based on the value of MCA

# 3. Capacity Table

## LSP Duct

### Cooling

TC : Total Capacity, SHC : Sensible Heat Capacity

Capacity Index	Outdoor Air Temp. ( °C,DB )	Indoor temperature													
		20(°C,DB)		23(°C,DB)		26(°C,DB)		27(°C,DB)		28(°C,DB)		30(°C,DB)		32(°C,DB)	
		14(°C,WB)		16(°C,WB)		18(°C,WB)		19(°C,WB)		20(°C,WB)		22(°C,WB)		24(°C,WB)	
		TC	SHC	TC	SHC	TC	SHC	TC	SHC	TC	SHC	TC	SHC	TC	SHC
017	35	1.2	1.0	1.4	1.2	1.6	1.3	1.7	1.3	1.8	1.3	1.9	1.3	2.0	1.2
022	35	1.5	1.2	1.8	1.4	2.1	1.6	2.2	1.6	2.3	1.6	2.4	1.6	2.6	1.5
028	35	1.9	1.6	2.3	1.8	2.6	1.9	2.8	2.0	2.9	2.0	3.1	2.0	3.3	1.9
036	35	2.5	2.0	2.9	2.3	3.4	2.5	3.6	2.6	3.7	2.6	4.0	2.6	4.2	2.4
045	35	3.1	2.7	3.7	3.1	4.2	3.2	4.5	3.3	4.7	3.3	5.0	3.3	5.3	3.1
056	35	3.9	3.3	4.6	3.8	5.3	4.0	5.6	4.2	5.8	4.2	6.2	4.2	6.6	4.0
071	35	4.9	4.3	5.8	5.0	6.7	5.2	7.1	5.4	7.4	5.6	7.9	5.6	8.4	5.3

### Heating

TC : Total Capacity (kW)

Capacity Index	Outdoor Air Temp. ( °C )		Indoor temperature ( °C,DB )				
			16(°C,DB)	18(°C,DB)	20(°C,DB)	22(°C,DB)	24(°C,DB)
			TC	TC	TC	TC	TC
	DB	WB	kW	kW	kW	kW	kW
017	7.0	6.0	2.1	2.0	1.9	1.8	1.7
022	7.0	6.0	2.8	2.7	2.5	2.3	2.2
028	7.0	6.0	3.3	3.2	3.2	3.0	2.7
036	7.0	6.0	4.1	4.1	4.0	3.7	3.4
045	7.0	6.0	5.1	5.1	5.0	4.6	4.2
056	7.0	6.0	6.5	6.4	6.3	5.8	5.3
071	7.0	6.0	8.2	8.1	8.0	7.4	6.8

### NOTE

- The performance table shows the average value of each conditions.

# 4. Dimensional Drawing

## LSP Duct

AM017HELDKG/EU, AM022HELDKG/EU, AM028HELDKG/EU, AM036HELDKG/EU  
AM045HELDKG/EU

Units : mm [inches]

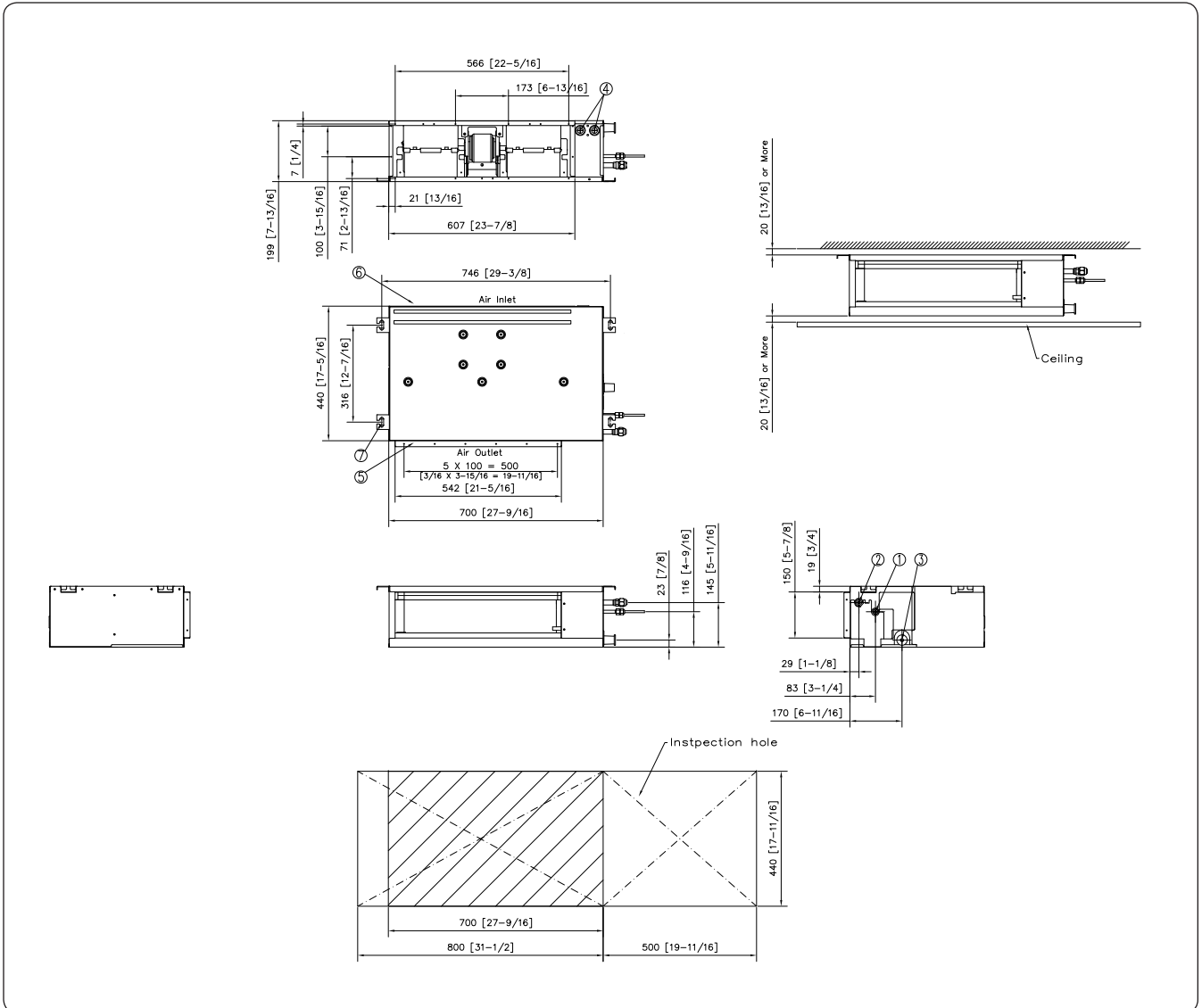

No.	Name	Description
①	Liquid pipe connection	Ø6.35 (1/4)
②	Gas pipe connection	Ø12.70 (1/2)
③	Drain pipe connection (Without drain pump)	VP25 (OD 32, ID 25)
④	Power & Communication Conduits	-
⑤	Air discharge grille flange	-
⑥	Return Air Side	-
⑦	Hook	Ø9.52 or M10

# 4. Dimensional Drawing

## LSP Duct

### AM056HELDKG/EU

Units : mm [inches]

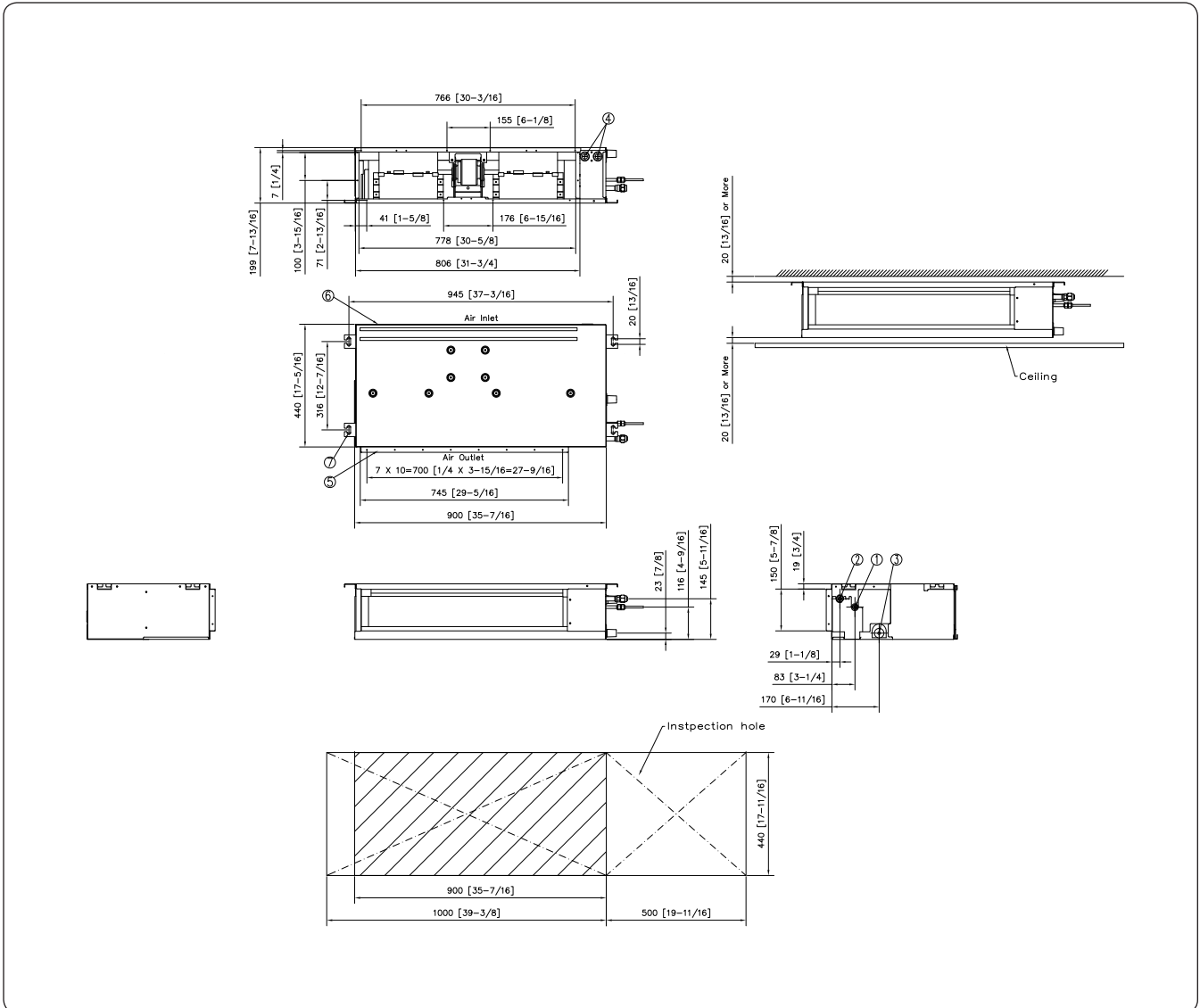

No.	Name	Description
①	Liquid pipe connection	Ø6.35 (1/4)
②	Gas pipe connection	Ø12.70 (1/2)
③	Drain pipe connection (Without drain pump)	VP25 (OD 32, ID 25)
④	Power & Communication Conduits	-
⑤	Air discharge grille flange	-
⑥	Return Air Side	-
⑦	Hook	Ø9.52 or M10

# 4. Dimensional Drawing

LSP Duct

AM071HELDKG/EU

Units : mm [inches]

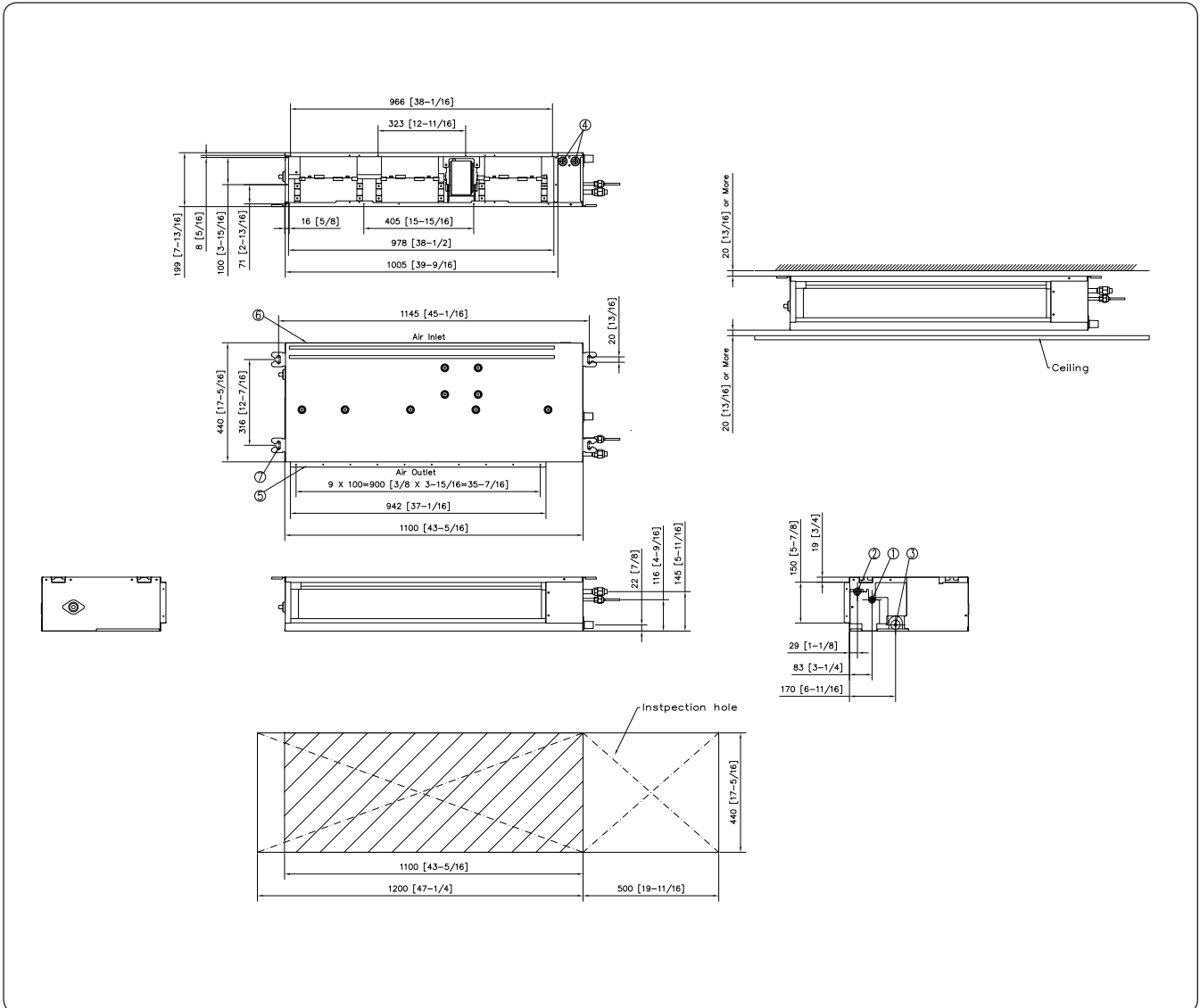

No.	Name	Description
①	Liquid pipe connection	Ø9.52 (3/8)
②	Gas pipe connection	Ø15.88 (5/8)
③	Drain pipe connection (Without drain pump)	VP25 (OD 32, ID 25)
④	Power & Communication Conduits	-
⑤	Air discharge grille flange	-
⑥	Return Air Side	-
⑦	Hook	Ø9.52 or M10

# 4. Dimensional Drawing

## LSP Duct

AM017DNLDKG/EU, AM022DNLDKG/EU, AM028DNLDKG/EU, AM036DNLDKG/EU

Units : mm [inches]

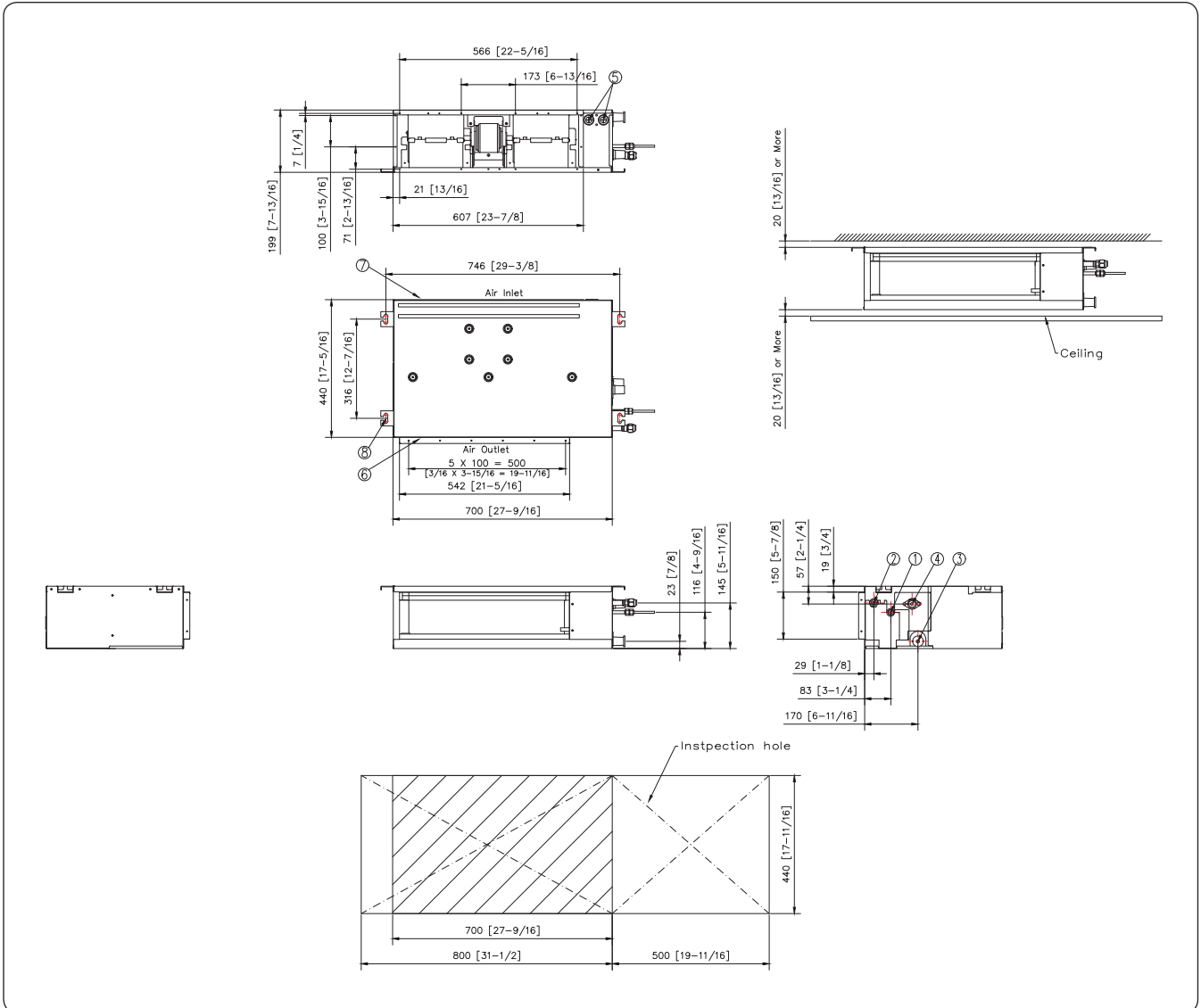

No.	Name	Description
①	Liquid pipe connection	Ø6.35 (1/4)
②	Gas pipe connection	Φ12.70 (1/2)
③	Drain pipe connection (Without drain pump)	VP25 (OD 32, ID 25)
④	Drain pipe connection (With drain pump)	-
⑤	Power & Communication Conduits	-
⑥	Air discharge grille flange	-
⑦	Return Air Side	-
⑧	Hook	Ø9.52 or M10

# 4. Dimensional Drawing

## LSP Duct

### AM045DNLDKG/EU, AM056DNLDKG/EU

Units : mm [inches]

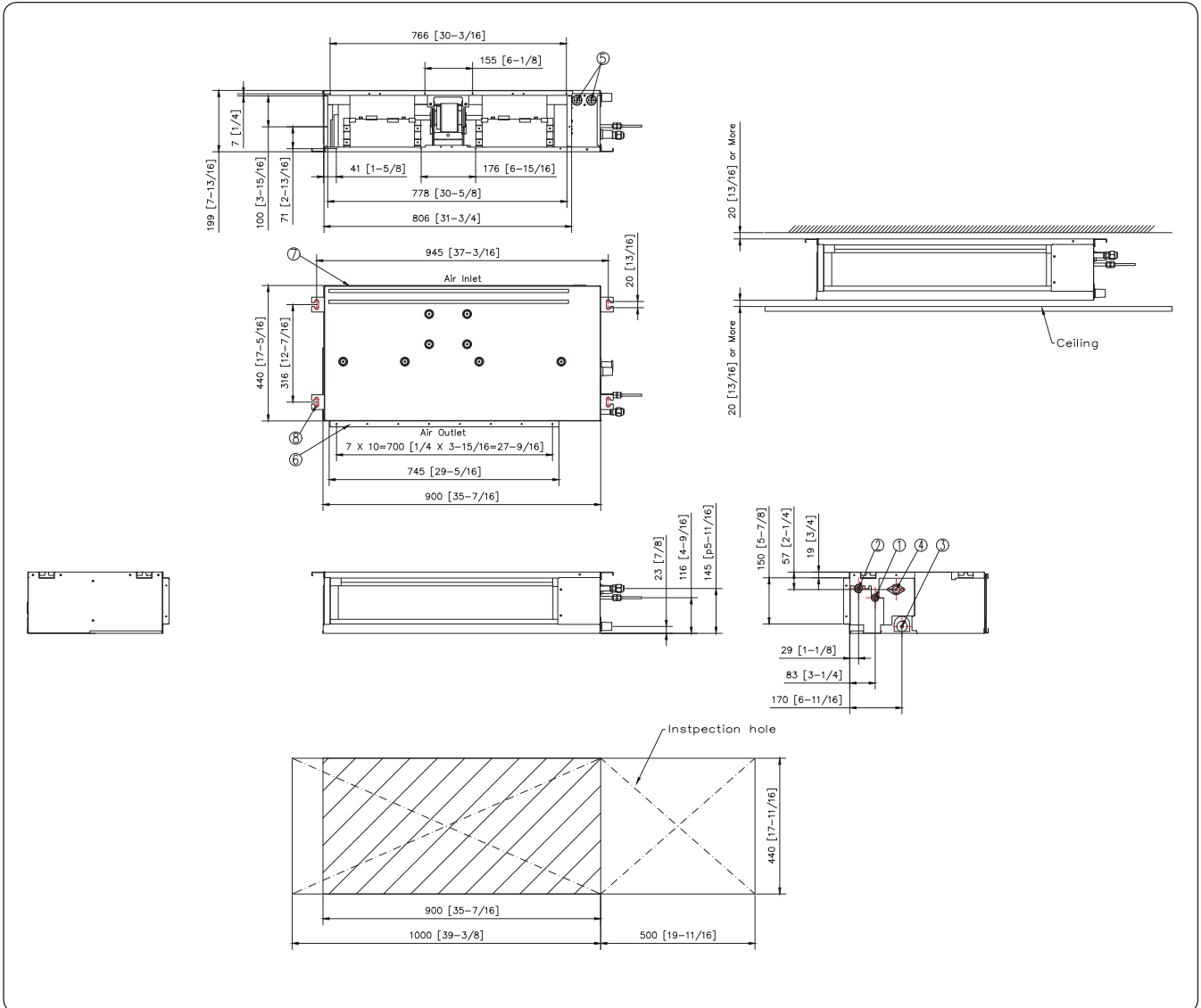

No.	Name	Description
①	Liquid pipe connection	Ø6.35 (1/4)
②	Gas pipe connection	Ø12.70 (1/2)
③	Drain pipe connection (Without drain pump)	VP25 (OD 32, ID 25)
④	Drain pipe connection (With drain pump)	-
⑤	Power & Communication Conduits	-
⑥	Air discharge grille flange	-
⑦	Return Air Side	-
⑧	Hook	Ø9.52 or M10

# 4. Dimensional Drawing

LSP Duct

AM071DNLDKG/EU

Units : mm [inches]

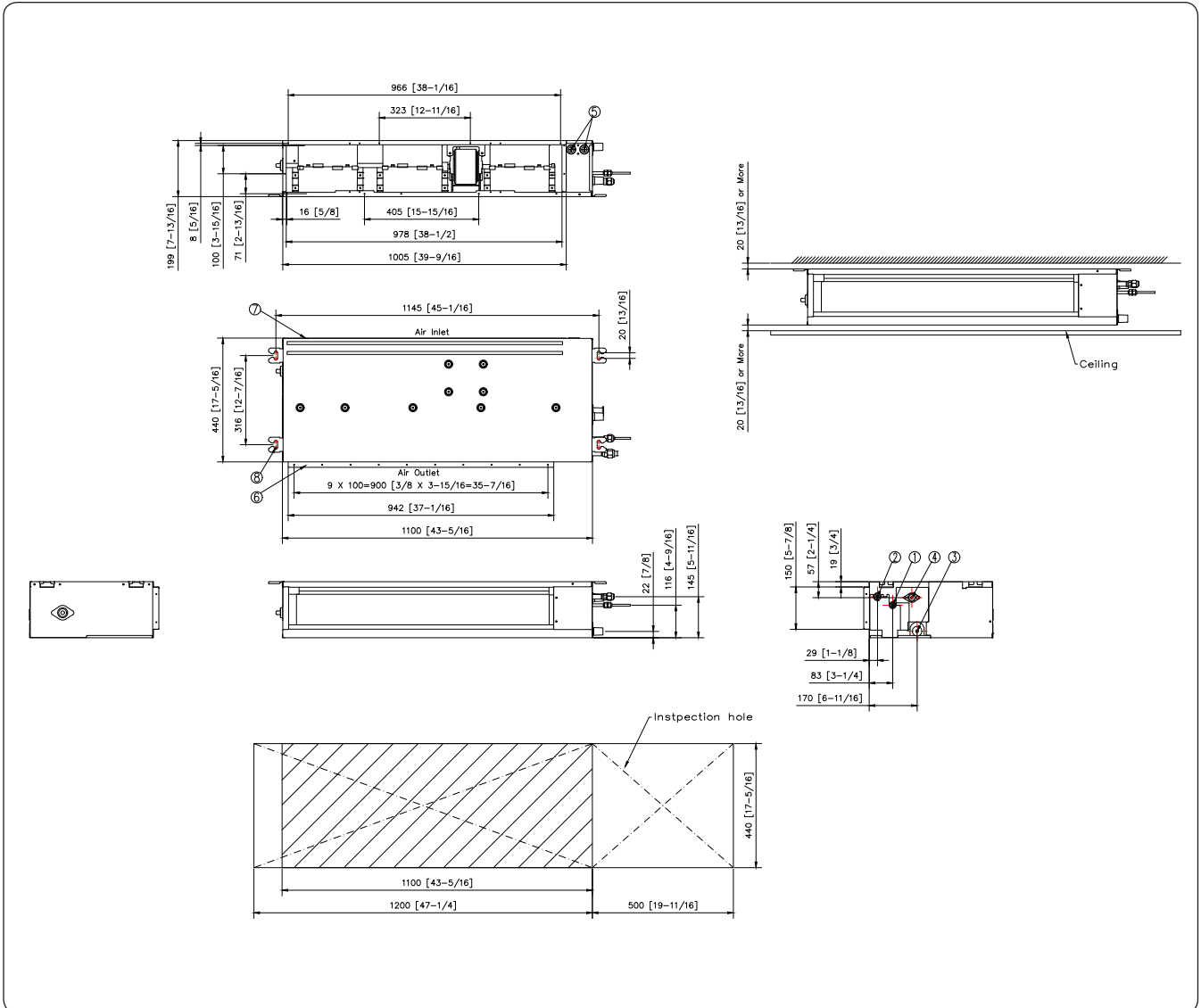

No.	Name	Description
①	Liquid pipe connection	Ø9.52 (3/8)
②	Gas pipe connection	Ø15.88 (5/8)
③	Drain pipe connection (Without drain pump)	VP25 (OD 32, ID 25)
④	Drain pipe connection (With drain pump)	-
⑤	Power & Communication Conduits	-
⑥	Air discharge grille flange	-
⑦	Return Air Side	-
⑧	Hook	Ø9.52 or M10

# 5. Center of Gravity

## LSP Duct

Units : mm [inches]

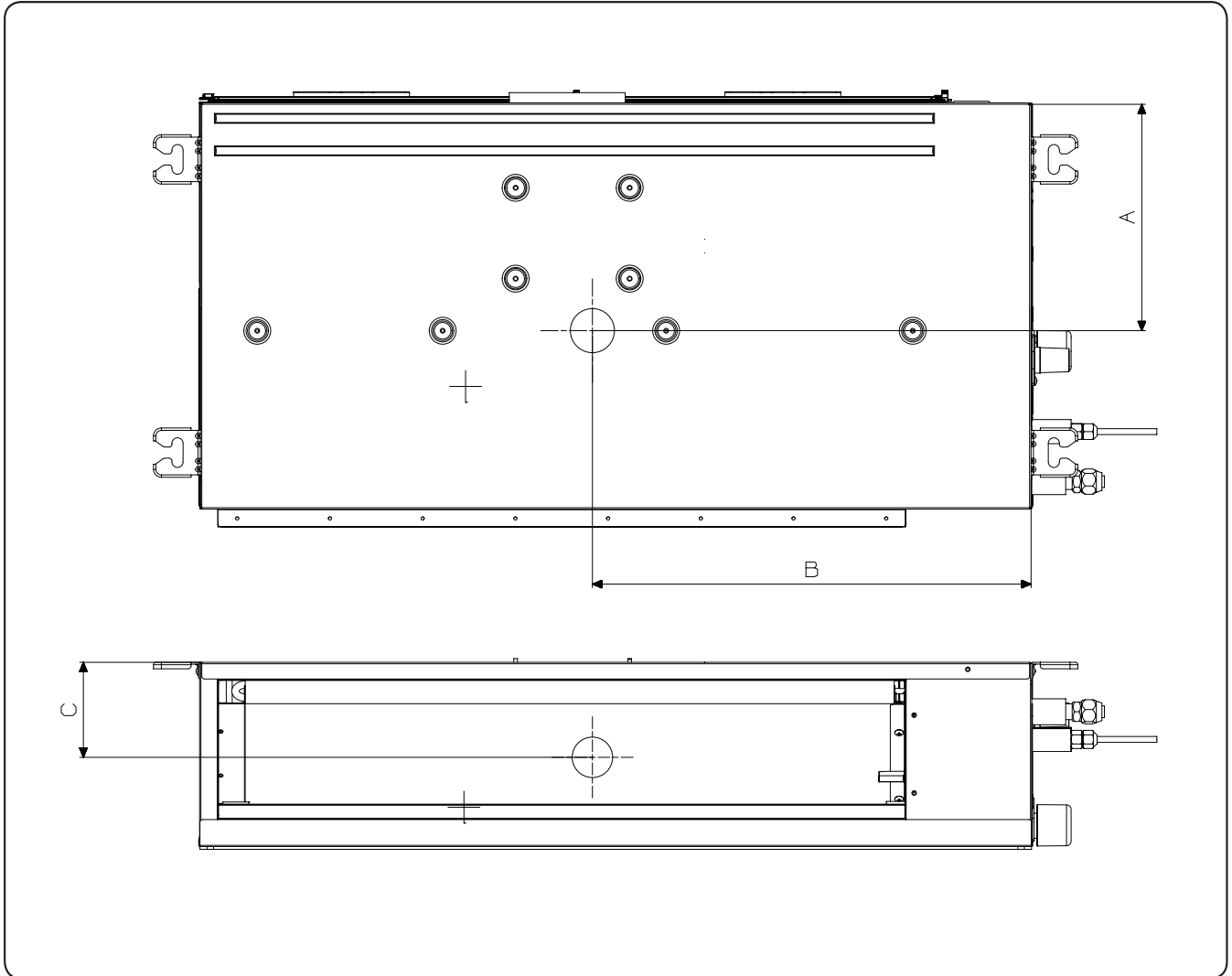

Model	A	B	C
AM017**LDKG/EU, AM022**LDKG/EU AM028**LDKG/EU, AM036**LDKG/EU AM045HELDKG/EU	230 [9-1/16]	356 [14]	100 [3-15/16]
AM045DNLDKG/EU, AM056**LDKG/EU	233 [9-3/16]	436 [17-3/16]	100 [3-15/16]
AM071**LDKG/EU	240 [9-7/16]	540 [21-1/4]	100 [3-15/16]

# 6. Electrical Wiring Diagram

## LSP Duct

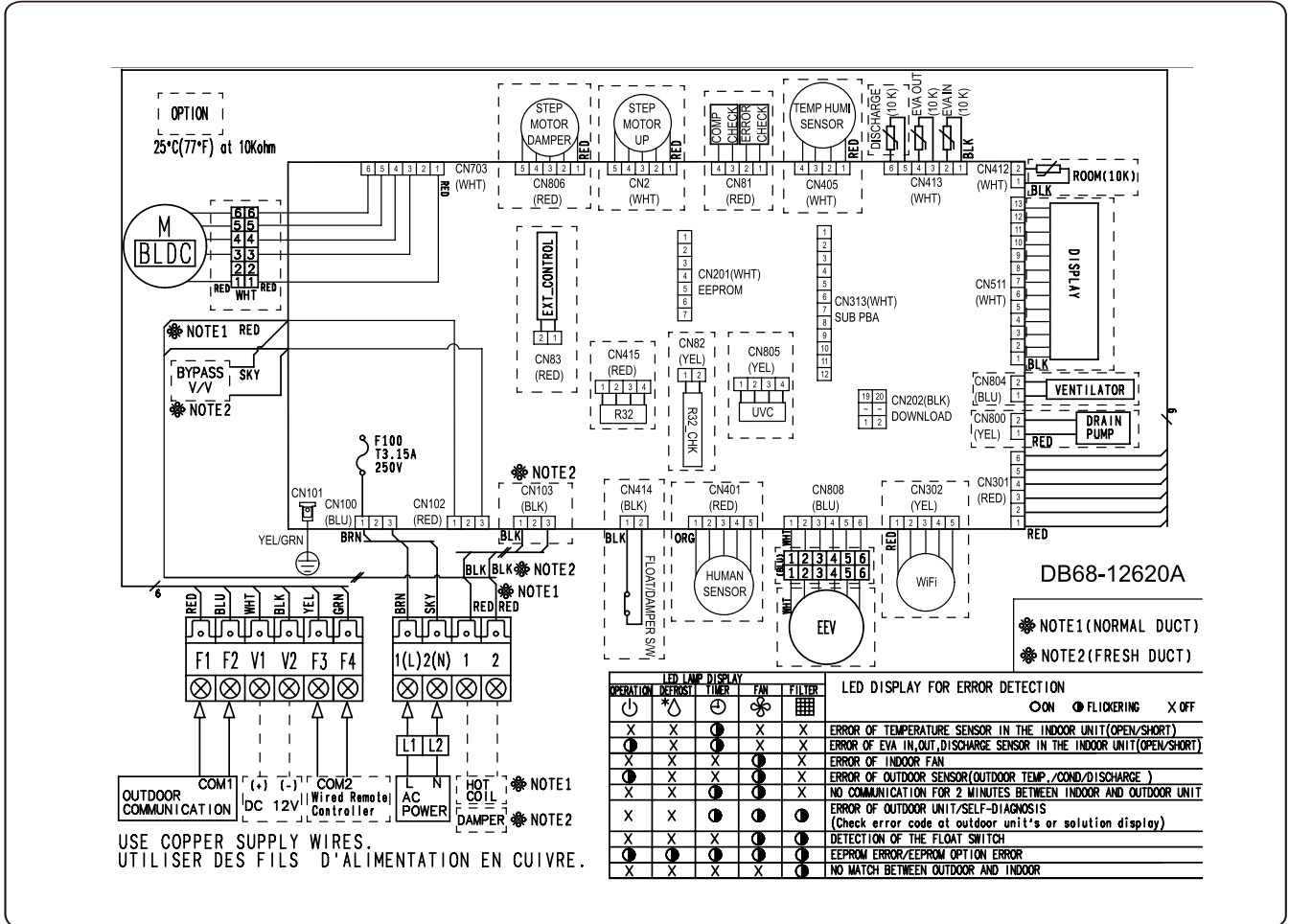

F100	Fuse	ROOM(10K)	Thermistor - Indoor Room
EEV	Electronic Expansion Valve	EVA IN (10K)	Thermistor - IDU heat exchanger In
M-BLDC	Motor for Indoor Fan	EVA OUT (10K)	Thermistor - IDU heat exchanger Out
ERROR CHECK	Contact output port for error check	EEPROM	EEPROM SUB PBA
COMP CHECK	Contact output port for compressor operation check	SUB PBA	SUB PBA for wired remote control communication
EXTERNAL CTRL	Input port for external contact control	DAMPER	Contact output port for Damper control
VENTILATOR	Contact output port for Ventilator control	HOT COIL	Contact output port for Hot coil control

### NOTE

- This wiring diagram applies only to the Indoor unit.
- Symbols show as follow : BLK: black, RED: red, BLU: blue, WHT: white, YEL: yellow, GRN: green
- For connection wiring indoor-outdoor transmission F1-F2, indoor-wired remote controller transmission F3-F4.
- ⊕ Protective earth(screw), □ : connector,  $\frac{N}{x}$  : The wire quantity

# 7. Sound Data

## LSP Duct

### Sound Pressure level

Unit: dB(A)

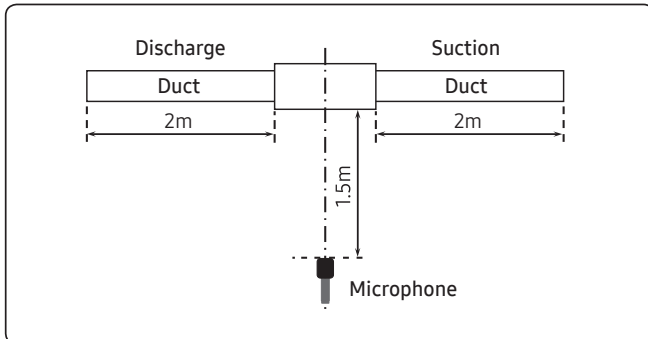

Model	High	Mid	Low
AM017HELDKG/EU	25	22	19
AM022HELDKG/EU	26	23	19
AM028HELDKG/EU	28	24	19
AM036HELDKG/EU	31	26	20

- NR Curve

1) AM017HELDKG/EU

2) AM022HELDKG/EU

# TBD

3) AM028HELDKG/EU

4) AM036HELDKG/EU

### NOTE

- Specifications may be subject to change without prior notice.
- Sound pressure Level
  - Sound pressure level is obtained in an anechoic room.
  - Sound pressure level is a relative value, depending on the distance and acoustic environment.
  - Sound pressure level may differ depending on operation condition.
  - dBA = A weighted sound pressure level
  - Reference acoustic pressure 0 dB = 20μPa

# 7. Sound Data

## LSP Duct

### Sound Pressure level

Unit: dB(A)

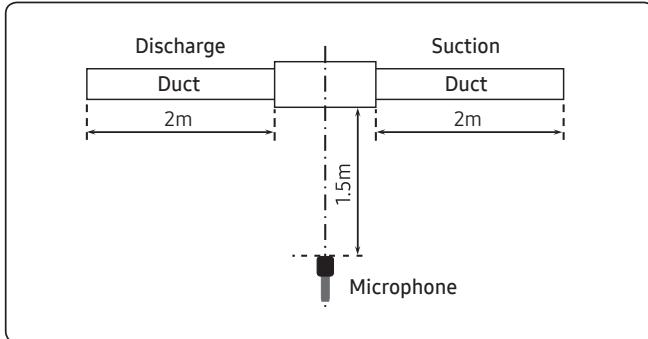

Model	High	Mid	Low
AM045HELDKG/EU	32	28	25
AM056HELDKG/EU	34	30	26
AM071HELDKG/EU	34	30	27

- NR Curve

1) AM045HELDKG/EU

2) AM056HELDKG/EU

# TBD

3) AM071HELDKG/EU

### NOTE

- Specifications may be subject to change without prior notice.
- Sound pressure Level
  - Sound pressure level is obtained in an anechoic room.
  - Sound pressure level is a relative value, depending on the distance and acoustic environment.
  - Sound pressure level may differ depending on operation condition.
  - dBA = A weighted sound pressure level
  - Reference acoustic pressure 0 dB = 20μPa

# 7. Sound Data

## LSP Duct

### Sound Pressure level

Unit: dB(A)

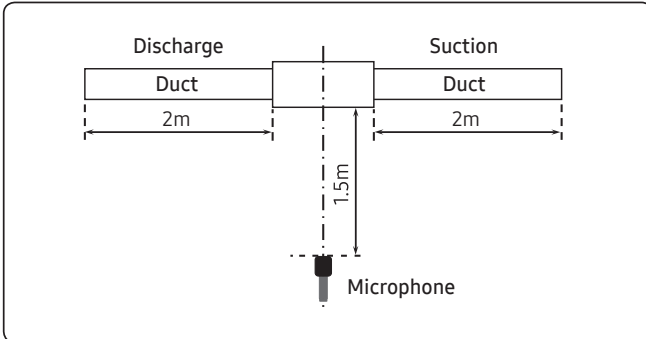

Model	High	Mid	Low
AM017DNLDKG/EU	25	22	19
AM022DNLDKG/EU	26	23	19
AM028DNLDKG/EU	28	24	19
AM036DNLDKG/EU	31	26	20

- NR Curve

1) AM017DNLDKG/EU

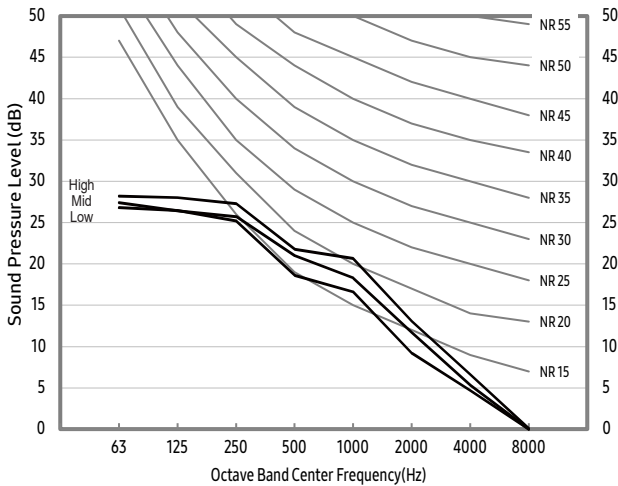

2) AM022DNLDKG/EU

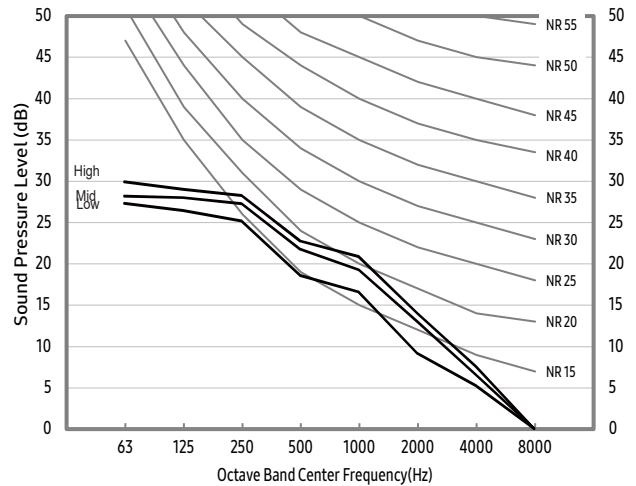

3) AM028DNLDKG/EU

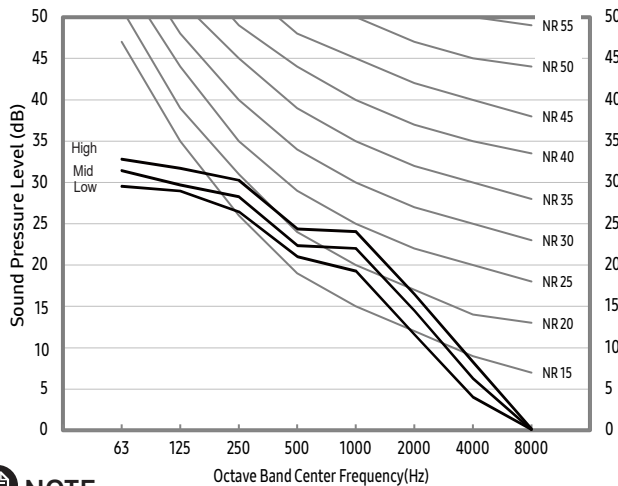

4) AM036DNLDKG/EU

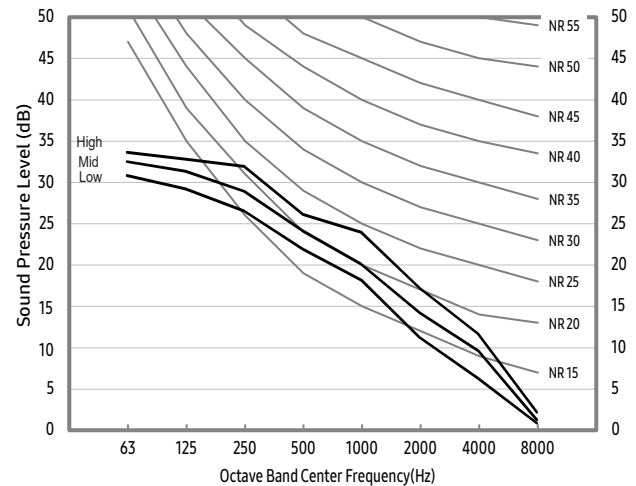

**NOTE**

- Specifications may be subject to change without prior notice.
- Sound pressure Level
  - Sound pressure level is obtained in an anechoic room.
  - Sound pressure level is a relative value, depending on the distance and acoustic environment.
  - Sound pressure level may differ depending on operation condition.
  - dBA = A weighted sound pressure level
  - Reference acoustic pressure 0 dB = 20μPa

# 7. Sound Data

## LSP Duct

### Sound Pressure level

Unit: dB(A)

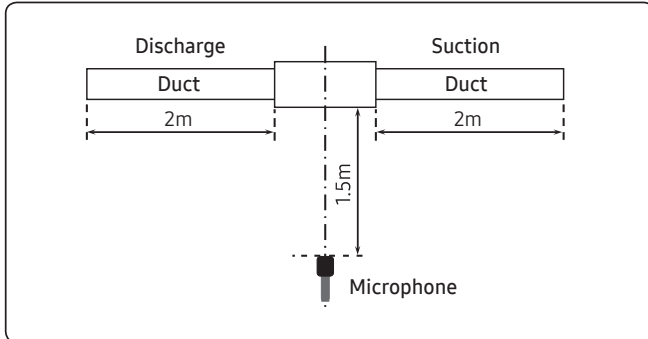

Model	High	Mid	Low
AM045DNLDKG/EU	32	28	25
AM056DNLDKG/EU	34	30	26
AM071DNLDKG/EU	34	30	27

- NR Curve

1) AM045DNLDKG/EU

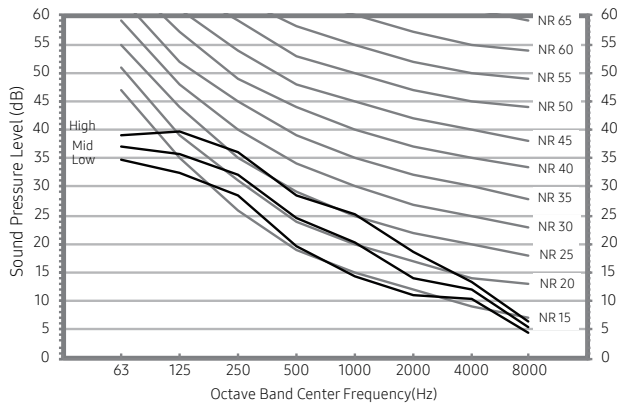

2) AM056DNLDKG/EU

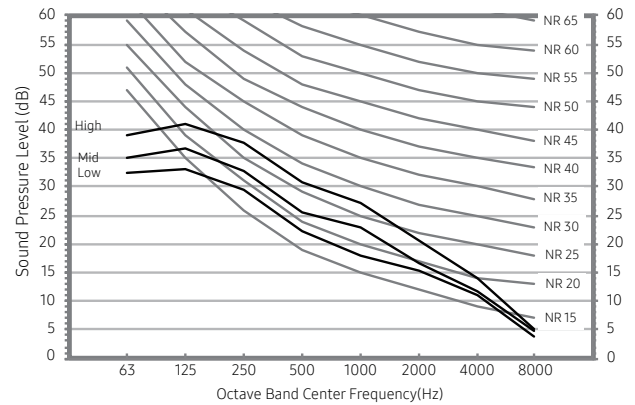

3) AM071DNLDKG/EU

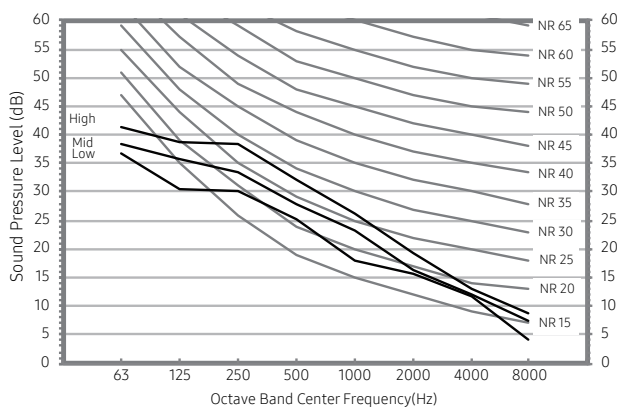

### NOTE

- Specifications may be subject to change without prior notice.
- Sound pressure Level
  - Sound pressure level is obtained in an anechoic room.
  - Sound pressure level is a relative value, depending on the distance and acoustic environment.
  - Sound pressure level may differ depending on operation condition.
  - dBA = A weighted sound pressure level
  - Reference acoustic pressure 0 dB = 20μPa

# 7. Sound Data

---

## LSP Duct

---

### Sound Power level

 **NOTE**

Unit: dB(A)

- Specifications may be subject to change without prior notice
  - Sound power level is an absolute value that a sound source generates.
  - dBA = A-weighted sound power level.
  - Reference power : 1pW.
  - Measured according to ISO 3741.

Model	Power
AM017HELDKG/EU	40
AM022HELDKG/EU	42
AM028HELDKG/EU	44
AM036HELDKG/EU	46

- NR Curve

1) AM017HELDKG/EU

2) AM022HELDKG/EU

TBD

3) AM028HELDKG/EU

4) AM036HELDKG/EU

---

# 7. Sound Data

---

## LSP Duct

---

### Sound Power level

 **NOTE**

Unit: dB(A)

- Specifications may be subject to change without prior notice
  - Sound power level is an absolute value that a sound source generates.
  - dBA = A-weighted sound power level.
  - Reference power : 1pW.
  - Measured according to ISO 3741.

Model	Power
AM045HELDKG/EU	47
AM056HELDKG/EU	49
AM071HELDKG/EU	49

- NR Curve

1) AM045HELDKG/EU

2) AM056HELDKG/EU

TBD

3) AM071HELDKG/EU

# 7. Sound Data

## LSP Duct

### Sound Power level

#### NOTE

- Specifications may be subject to change without prior notice
  - Sound power level is an absolute value that a sound source generates.
  - dBA = A-weighted sound power level.
  - Reference power : 1pW.
  - Measured according to ISO 3741.

Unit: dB(A)

Model	Power
AM017DNLDKG/EU	40
AM022DNLDKG/EU	42
AM028DNLDKG/EU	44
AM036DNLDKG/EU	46

#### • NR Curve

1) AM017DNLDKG/EU

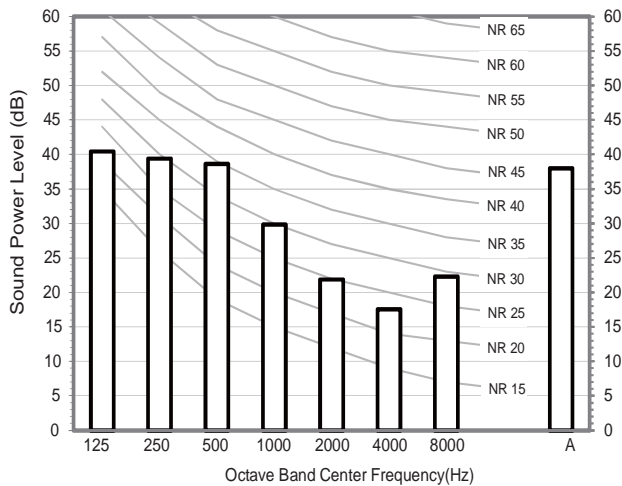

2) AM022DNLDKG/EU

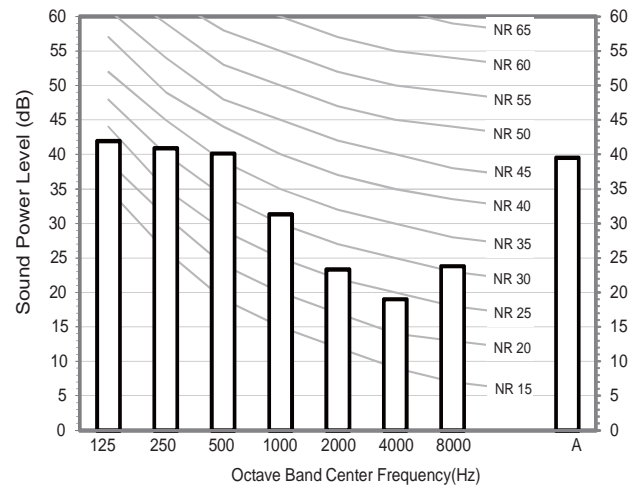

3) AM028DNLDKG/EU

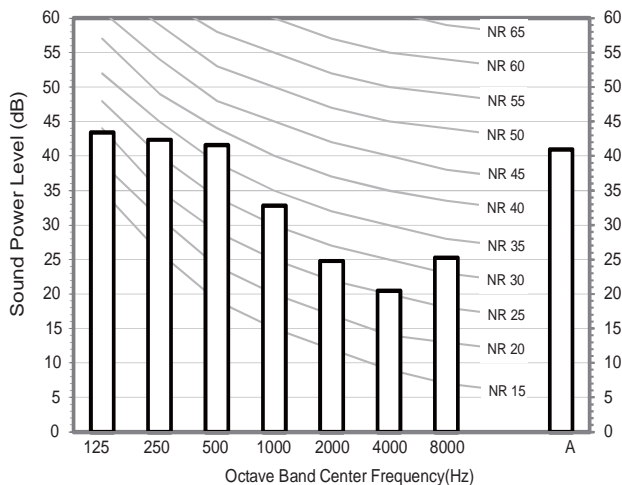

4) AM036DNLDKG/EU

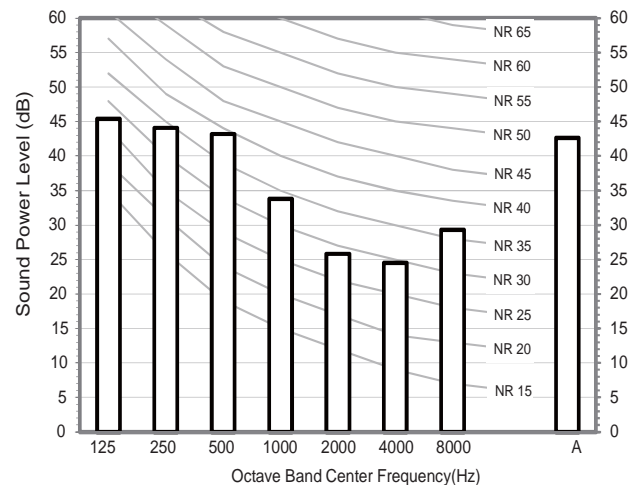

# 7. Sound Data

## LSP Duct

### Sound Power level

#### NOTE

Unit: dB(A)

- Specifications may be subject to change without prior notice
  - Sound power level is an absolute value that a sound source generates.
  - dBA = A-weighted sound power level.
  - Reference power : 1pW.
  - Measured according to ISO 3741.

Model	Power
AM045DNLDKG/EU	47
AM056DNLDKG/EU	49
AM071DNLDKG/EU	49

#### NR Curve

1) AM045DNLDKG/EU

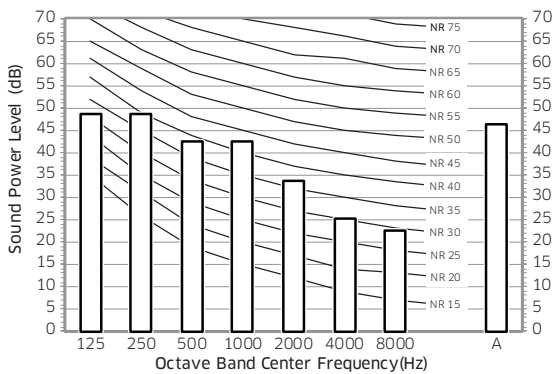

2) AM056DNLDKG/EU

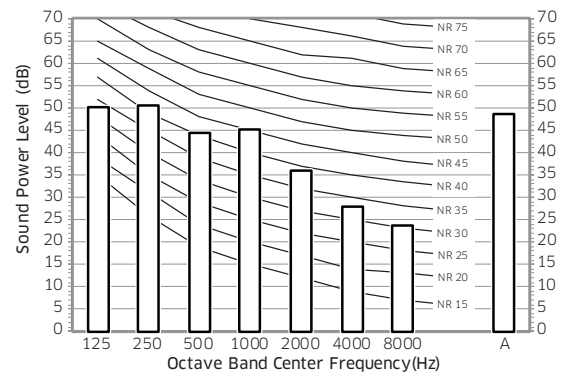

3) AM071DNLDKG/EU

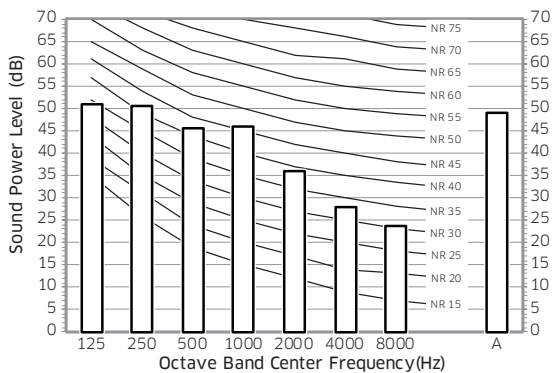

# 8. Fan Characteristics

## LSP Duct

### AM017HELDKG/EU

①	External Static Pressure(mmAq)	Option Code
	$0 < SP \leq 0.5$	010054-12549E-201111-331110

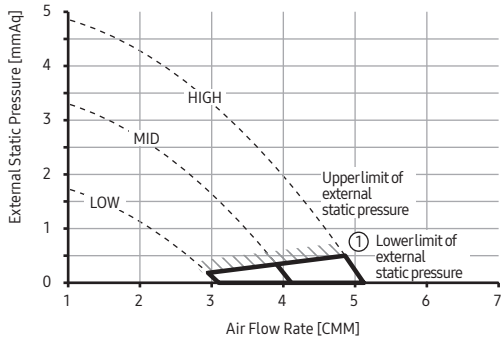

②	External Static Pressure(mmAq)	Option Code
	$0.5 < SP \leq 2$	010054-125581-201111-331110

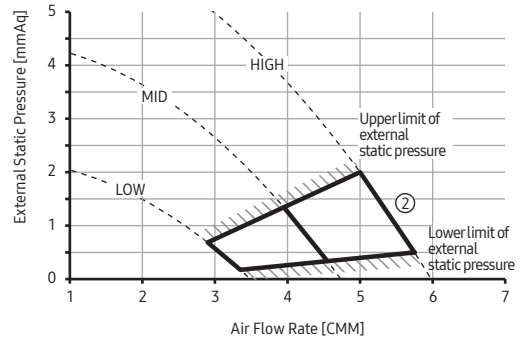

③	External Static Pressure(mmAq)	Option Code
	$2 < SP \leq 3$	010054-1255F5-201111-331110

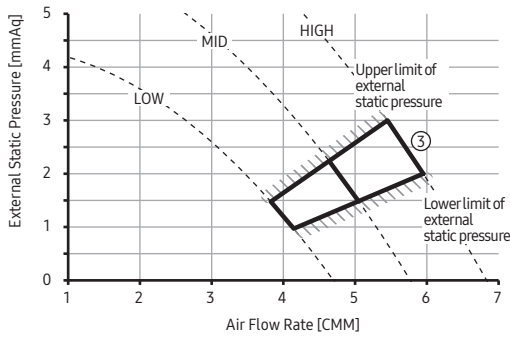

# 8. Fan Characteristics

## LSP Duct

### AM022HELDKG/EU

①	External Static Pressure(mmAq)	Option Code
	$0 < SP \leq 0.5$	010054-125A80-201616-331110

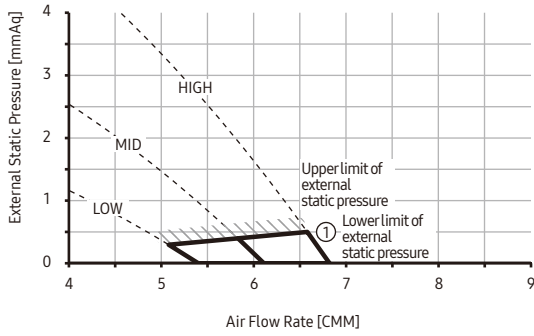

②	External Static Pressure(mmAq)	Option Code
	$0.5 < SP \leq 2$	010054-125AC3-201616-331110

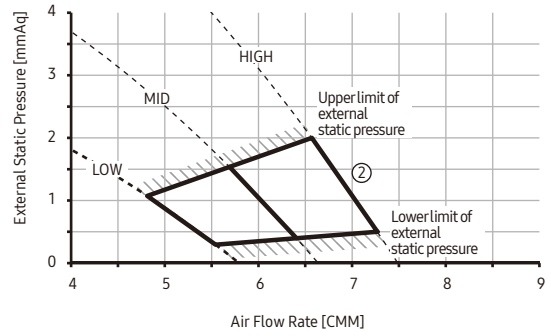

③	External Static Pressure(mmAq)	Option Code
	$2 < SP \leq 3$	010054-125E08-201616-331110

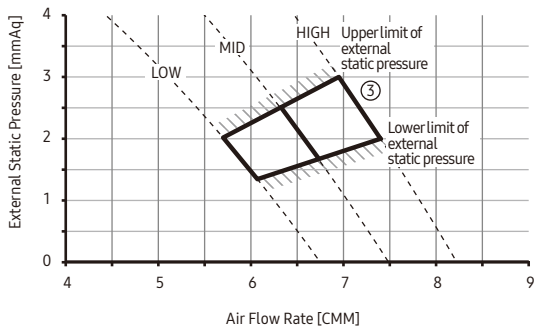

# 8. Fan Characteristics

## LSP Duct

### AM028HELDKG/EU

①	External Static Pressure(mmAq)	Option Code
	$0 < SP \leq 0.5$	010054-125AEZ-201C1C-331110

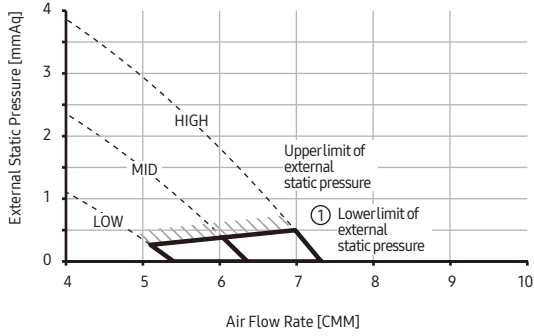

②	External Static Pressure(mmAq)	Option Code
	$0.5 < SP \leq 2$	010054-125E15-201C1C-331110

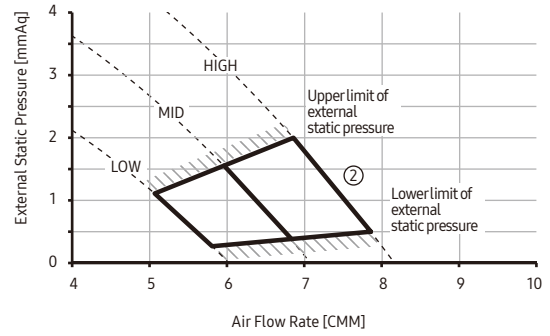

③	External Static Pressure(mmAq)	Option Code
	$2 < SP \leq 3$	010054-125E7A-201C1C-331110

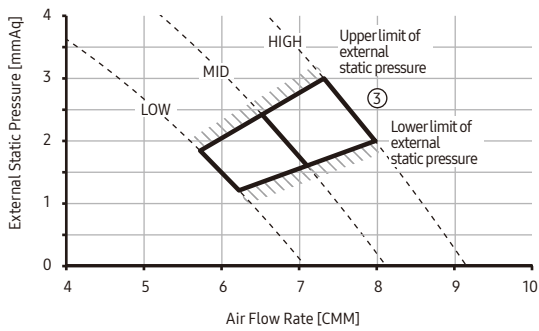

# 8. Fan Characteristics

## LSP Duct

### AM036HELDKG/EU

①	External Static Pressure(mmAq)	Option Code
	$0 < SP \leq 0.5$	010054-125E35-202424-331110

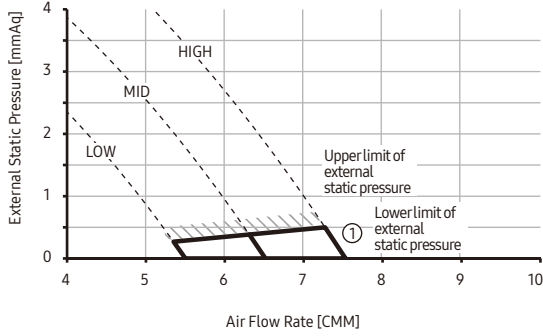

②	External Static Pressure(mmAq)	Option Code
	$0.5 < SP \leq 2$	010054-125E68-202424-331110

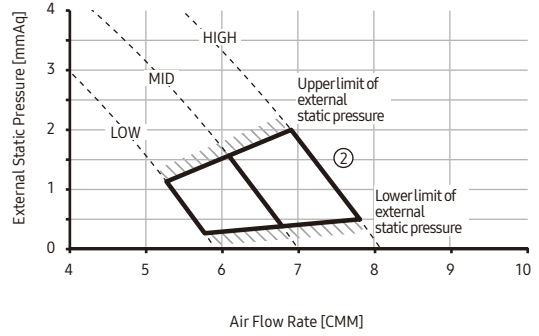

③	External Static Pressure(mmAq)	Option Code
	$2 < SP \leq 3$	010054-125ECD-202424-331110

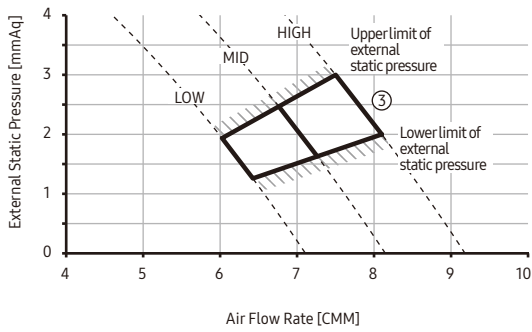

# 8. Fan Characteristics

## LSP Duct

### AM045HELDKG/EU

External Static Pressure(mmAq)	Option Code	Air Flow [CMM]		
		High	Mid	Low
0	010454-1C5458-202D2D-301110	7.5	10.0	12.5

External Static Pressure(mmAq)	Option Code
0 < P ≤ 2	010454-1C54EA-202D2D-301110

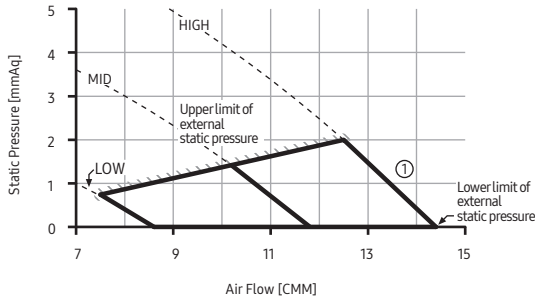

External Static Pressure(mmAq)	Option Code
2 < P ≤ 4	010454-1C585F-202D2D-301110

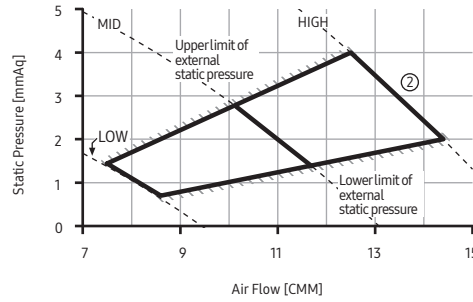

### AM056HELDKG/EU

External Static Pressure(mmAq)	Option Code	Air Flow [CMM]		
		High	Mid	Low
0	010454-1C54FC-203838-301110	9.5	12.5	15.5

External Static Pressure(mmAq)	Option Code
0 < P ≤ 2	010454-1C5950-203838-301110

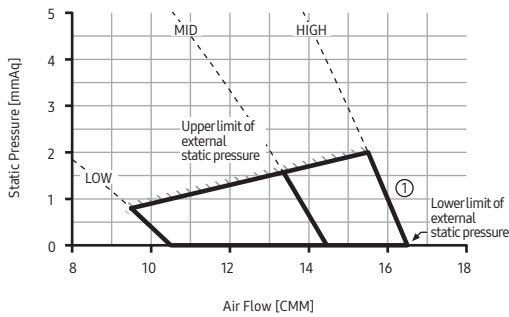

External Static Pressure(mmAq)	Option Code
2 < P ≤ 4	010454-1C59C4-203838-301110

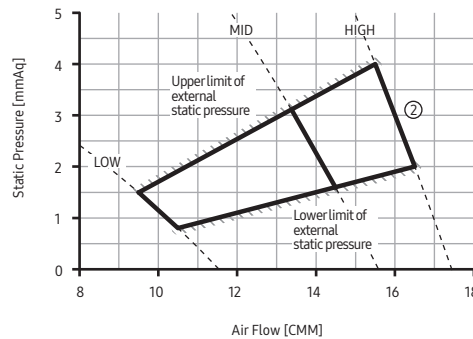

### AM071HELDKG/EU

External Static Pressure(mmAq)	Option Code	Air Flow [CMM]		
		High	Mid	Low
0	010454-1C54D9-204747-301110	11.0	14.5	18.0

External Static Pressure(mmAq)	Option Code
0 < P ≤ 2	010454-1C584E-204747-301110

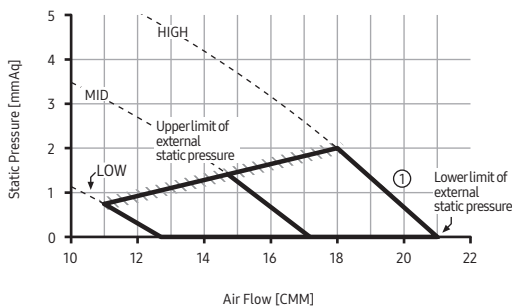

External Static Pressure(mmAq)	Option Code
2 < P ≤ 4	010454-1C59B2-204747-301110

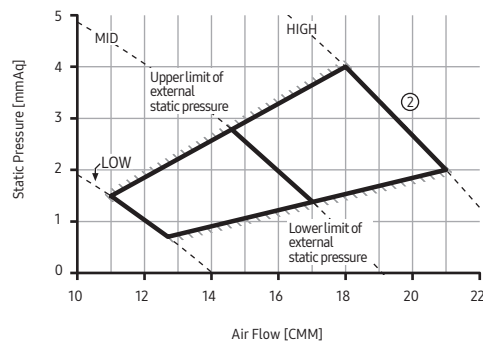

# 8. Fan Characteristics

## LSP Duct

### AM017DNLDKG/EU

①	External Static Pressure(mmAq)	Option Code
	$0 < SP \leq 0.5$	010054-12549E-201111-331110

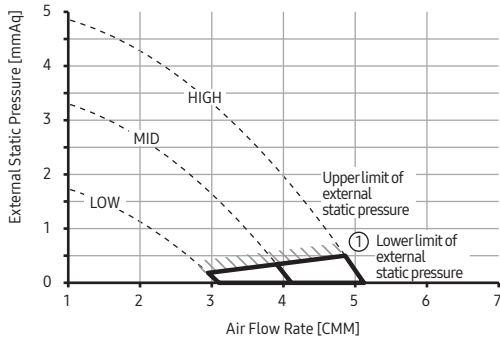

②	External Static Pressure(mmAq)	Option Code
	$0.5 < SP \leq 2$	010054-1255B1-201111-331110

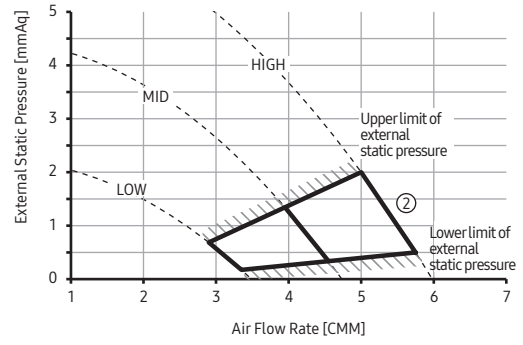

③	External Static Pressure(mmAq)	Option Code
	$2 < SP \leq 3$	010054-1255F5-201111-331110

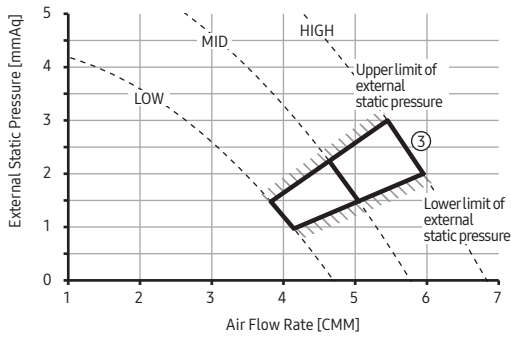

# 8. Fan Characteristics

## LSP Duct

### AM022DNLDKG/EU

①	External Static Pressure(mmAq)	Option Code
	$0 < SP \leq 0.5$	010054-125A80-201616-331110

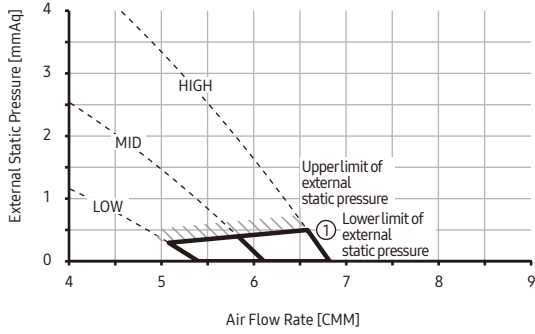

②	External Static Pressure(mmAq)	Option Code
	$0.5 < SP \leq 2$	010054-125AC3-201616-331110

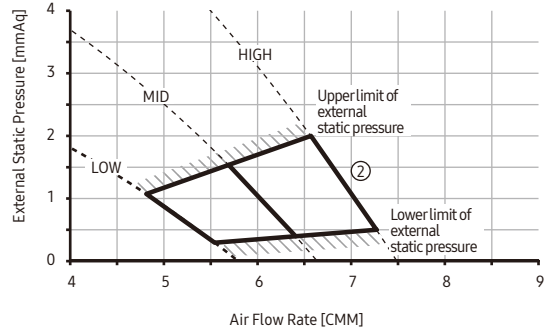

③	External Static Pressure(mmAq)	Option Code
	$2 < SP \leq 3$	010054-125E08-201616-331110

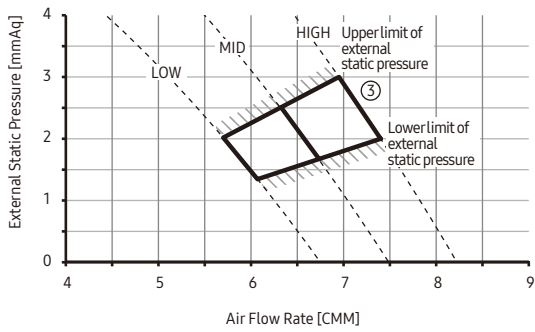

# 8. Fan Characteristics

## LSP Duct

### AM028DNLDKG/EU

①	External Static Pressure(mmAq)	Option Code
	$0 < SP \leq 0.5$	010054-125AEZ-201C1C-331110

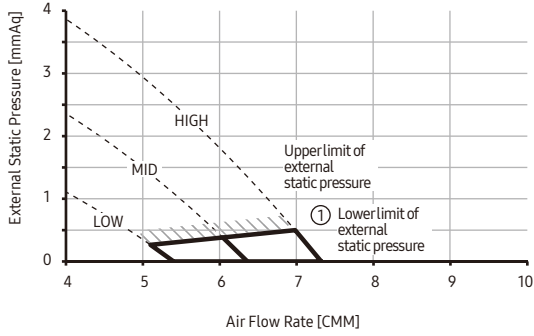

②	External Static Pressure(mmAq)	Option Code
	$0.5 < SP \leq 2$	010054-125E15-201C1C-331110

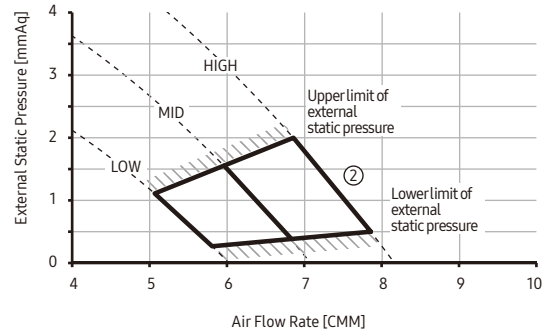

③	External Static Pressure(mmAq)	Option Code
	$2 < SP \leq 3$	010054-125E7A-201C1C-331110

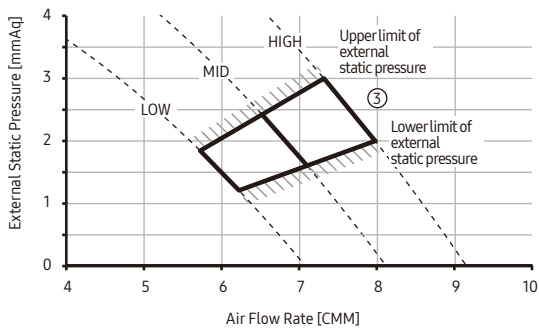

# 8. Fan Characteristics

## LSP Duct

### AM036DNLDKG/EU

①	External Static Pressure(mmAq)	Option Code
	$0 < SP \leq 0.5$	010054-125E35-202424-331110

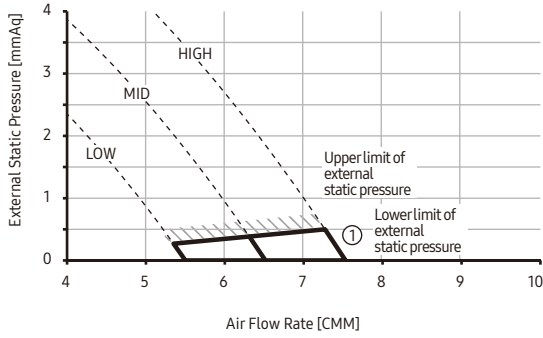

②	External Static Pressure(mmAq)	Option Code
	$0.5 < SP \leq 2$	010054-125E68-202424-331110

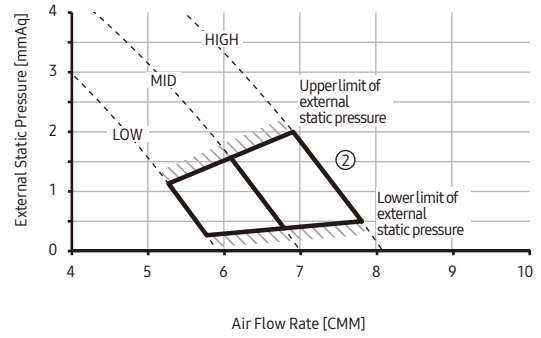

③	External Static Pressure(mmAq)	Option Code
	$2 < SP \leq 3$	010054-125ECD-202424-331110

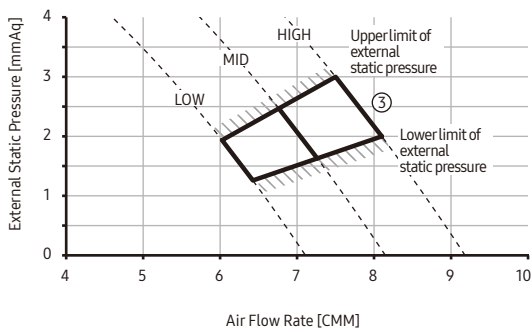

# 8. Fan Characteristics

## LSP Duct

### AM045DNLDKG/EU

External Static Pressure(mmAq)	Option Code	Air Flow [CMM]		
		High	Mid	Low
0	010454-1C5458-202D2D-301110	7.5	10.0	12.5

External Static Pressure(mmAq)	Option Code
0 < P ≤ 2	010454-1C54EA-202D2D-301110

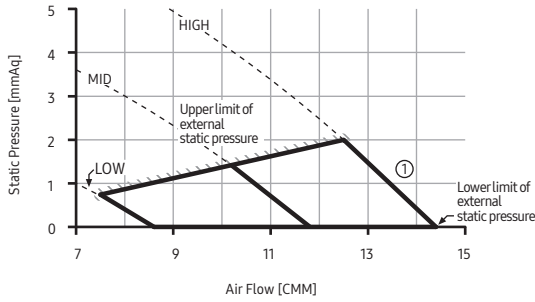

External Static Pressure(mmAq)	Option Code
2 < P ≤ 4	010454-1C585F-202D2D-301110

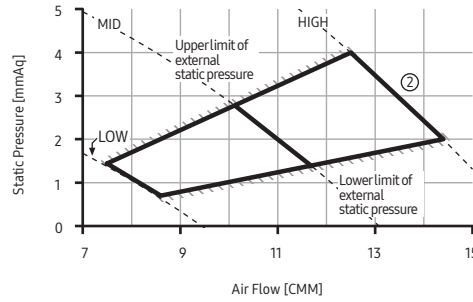

### AM056DNLDKG/EU

External Static Pressure(mmAq)	Option Code	Air Flow [CMM]		
		High	Mid	Low
0	010454-1C54FC-203838-301110	9.5	12.5	15.5

External Static Pressure(mmAq)	Option Code
0 < P ≤ 2	010454-1C5950-203838-301110

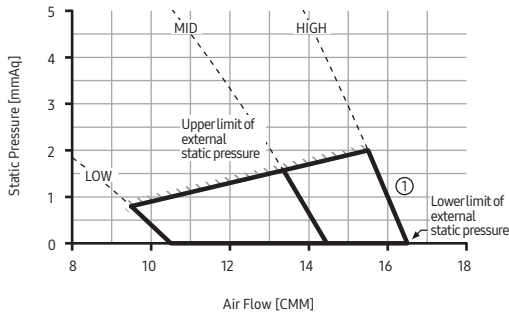

External Static Pressure(mmAq)	Option Code
2 < P ≤ 4	010454-1C59C4-203838-301110

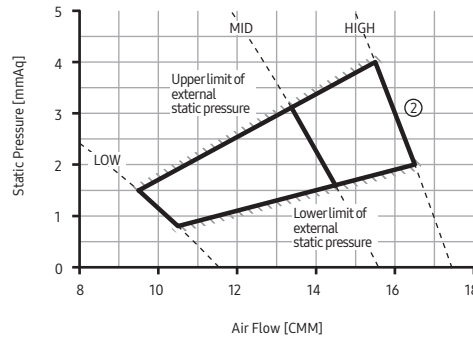

### AM071DNLDKG/EU

External Static Pressure(mmAq)	Option Code	Air Flow [CMM]		
		High	Mid	Low
0	010454-1C54D9-204747-301110	11.0	14.5	18.0

External Static Pressure(mmAq)	Option Code
0 < P ≤ 2	010454-1C584E-204747-301110

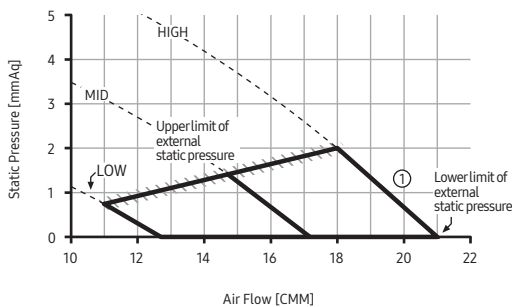

External Static Pressure(mmAq)	Option Code
2 < P ≤ 4	010454-1C59B2-204747-301110

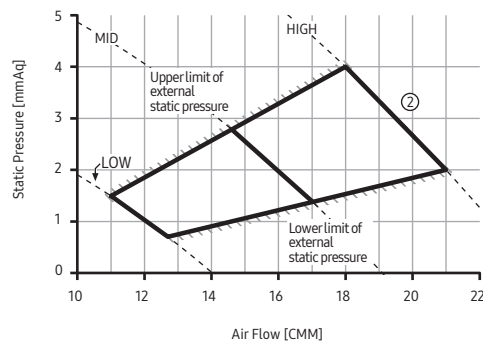

# 9. Piping Diagram

## LSP Duct

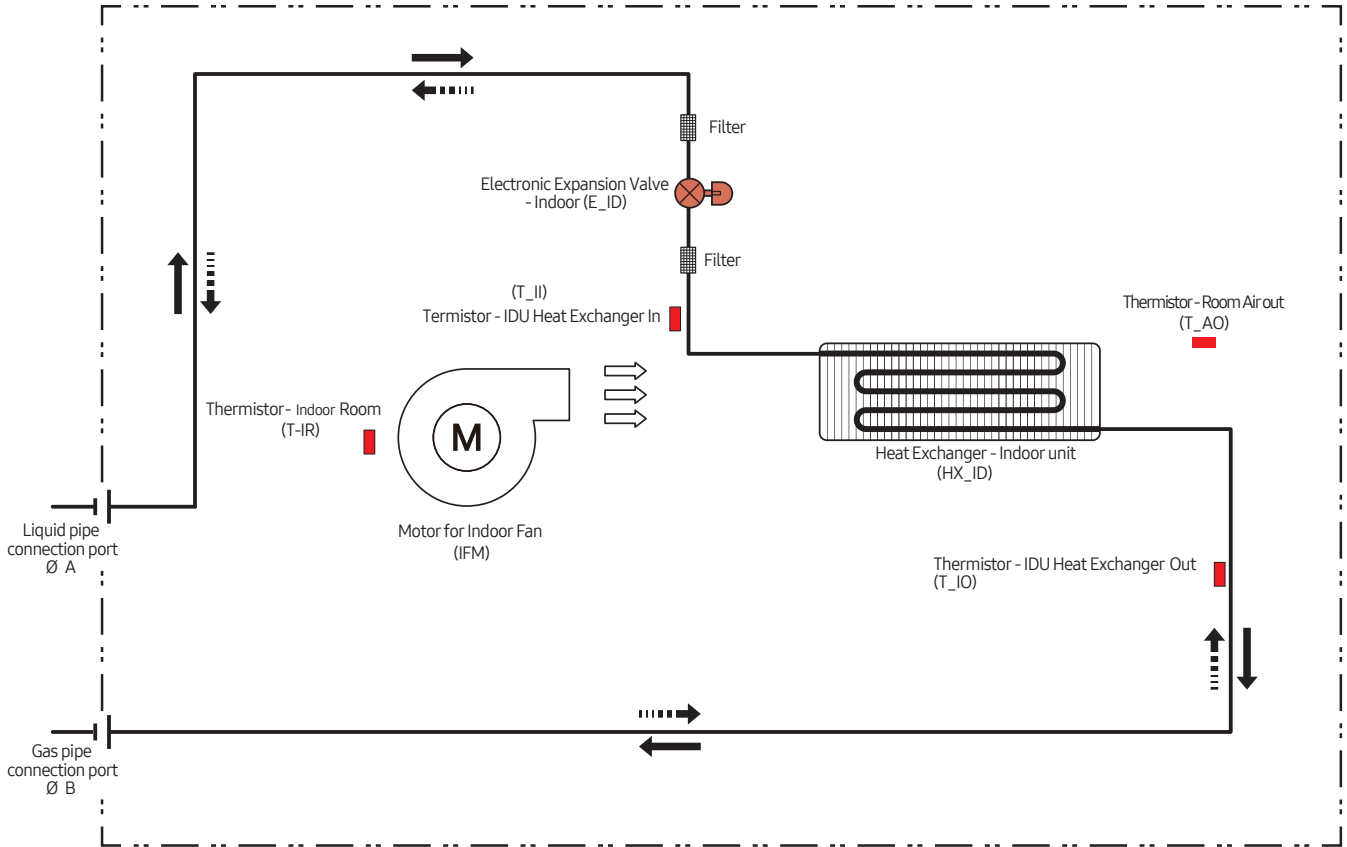

Refrigerant flow	
Cooling	Heating

# MSP Duct

---



<b>1. Specification</b>	<b>153</b>
<b>2. Summary Table</b>	<b>159</b>
<b>3. Capacity Table</b>	<b>161</b>
<b>4. Dimensional Drawing</b>	<b>163</b>
<b>5. Center of Gravity</b>	<b>166</b>
<b>6. Electrical Wiring Diagram</b>	<b>167</b>
<b>7. Sound Data</b>	<b>168</b>
<b>8. Fan Characteristics</b>	<b>178</b>
<b>9. Piping Diagram</b>	<b>195</b>

---



# Line-up

## MSP Duct

### Deluxe

Capacity (kW)											
2.2	2.8	3.6	4.5	5.6	7.1	9.0		11.2	12.8	14.0	16.0
											

### Flagship

Capacity (kW)						
2.2	2.8	3.6	4.5	5.6	7.1	
						

# 1. Specification

## MSP Duct

Model Name			AM022DNMDKG/EU	AM028DNMDKG/EU	AM036DNMDKG/EU	
Power Supply			Φ, #, V, Hz	1,2,220~240,50/60	1,2,220~240,50/60	1,2,220~240,50/60
Performance	Capacity	Cooling	kW	2.2	2.8	3.6
			Btu/h	7,500	9,600	12,300
		Heating	kW	2.5	3.2	4.0
			Btu/h	8,500	10,900	13,600
Power	Power Input	Cooling	W	42.0	42.0	45.0
		Heating		42.0	42.0	45.0
	Current Input	Cooling	A	0.4	0.4	0.4
		Heating		0.4	0.4	0.4
	Current	MCA	A	0.67	0.67	0.81
		MFA		15	15	15
Heat exchanger	Type		-	Fin & Tube	Fin & Tube	Fin & Tube
	Material	Fin	-	Al	Al	Al
		Tube	-	Cu	Cu	Cu
	Fin Treatment		-	hydrophilic	hydrophilic	hydrophilic
Fan	Type		-	Sirocco Fan	Sirocco Fan	Sirocco Fan
	Quantity		EA	2	2	2
	Air Flow Rate	H/M/L	m <sup>3</sup> /min	10.5 / 9 / 7	10.5 / 9 / 7	12 / 9.5 / 7.5
			l/s	175 / 150 / 117	175 / 150 / 117	208 / 158 / 125
	External Pressure	Min/Std/Max	mmAq	0 / 2.5 / 15	0 / 2.5 / 15	0 / 2.5 / 15
			Pa	0 / 24.52 / 147.1	0 / 24.52 / 147.1	0 / 24.52 / 147.1
Fan Motor	Type		-	BLDC	BLDC	BLDC
	Output x n		W	153	153	153
Piping Connections	Liquid Pipe		Type	Flare connection	Flare connection	Flare connection
			Φ, mm (inch)	6.35 (1/4)	6.35 (1/4)	6.35 (1/4)
	Gas Pipe		Type	Flare connection	Flare connection	Flare connection
			Φ, mm (inch)	12.7 (1/2)	12.7 (1/2)	12.7 (1/2)
Drain Pipe		Φ,inch	VP25 (OD 32,ID 25)	VP25 (OD 32,ID 25)	VP25 (OD 32,ID 25)	
Wiring connections	Communication (Min.)		mm <sup>2</sup>	0.75	0.75	0.75
			-	F1, F2	F1, F2	F1, F2
Refrigerant	Type		-	R32	R32	R32
	Control Method		-	EEV	EEV	EEV
Sound	Sound Pressure Level	H/M/L	dB(A)	28 / 26 / 24	28 / 26 / 24	30 / 27 / 24
	Sound Power Level	Cooling		50	51	53
External Dimension	Net Weight		kg	27.0	27.0	27.0
	Shipping Weight		kg	30.5	30.5	30.5
	Net Dimensions (W×H×D)		mm	850 x 250 x 700	850 x 250 x 700	850 x 250 x 700
	Shipping Dimensions (W×H×D)		mm	1,064 x 320 x 784	1,064 x 320 x 784	1,064 x 320 x 784
Casing	Material		-	Steel	Steel	Steel
Additional Accessories	Drain pump	External Model	-	-	-	-
		Internal Model	-	Built in	Built in	Built in
		Max. lifting	mm / Liter/h	750 / 24	750 / 24	750 / 24
	Air Filter		-	-	-	-

### NOTE

- Specification may be subject to change without prior notice.
  - 1) Capacities are based on (Equivalent refrigerant piping 7.5m, Level differences 0m);
    - Cooling : Indoor temperature 27°C DB, 19°C WB / Outdoor temperature 35°C DB, 24°C WB
    - Heating : Indoor temperature 20°C DB, 15°C WB / Outdoor temperature 7°C DB, 6°C WB
  - 2) Sound level was acquired in an anechoic room. Thus actual noise level may be different depending on the installation conditions.
  - 3) These products contain R32 (GWP=675) which is fluorinated greenhouse gas.
  - 4) Select wire size based on the value of MCA

# 1. Specification

## MSP Duct

Model Name				AM045DNMDKG/EU	AM056DNMDKG/EU	AM071DNMDKG/EU
Power Supply			Φ, #, V, Hz	1,2,220~240,50/60	1,2,220~240,50/60	1,2,220~240,50/60
Performance	Capacity	Cooling	kW	4.5	5.6	7.1
			Btu/h	15,400	19,100	24,200
		Heating	kW	5.0	6.3	8.0
			Btu/h	17,100	21,500	27,300
Power	Power Input	Cooling	W	55.0	70.0	110.0
		Heating		55.0	70.0	110.0
	Current Input	Cooling	A	0.5	0.6	1.0
		Heating		0.5	0.6	1.0
	Current	MCA	A	0.89	1.08	1.48
		MFA		15	15	15
Heat exchanger	Type		-	Fin & Tube	Fin & Tube	Fin & Tube
	Material	Fin	-	Al	Al	Al
		Tube	-	Cu	Cu	Cu
	Fin Treatment		-	hydrophilic	hydrophilic	hydrophilic
Fan	Type		-	Sirocco Fan	Sirocco Fan	Sirocco Fan
	Quantity		EA	2	2	2
	Air Flow Rate	H/M/L	m <sup>3</sup> /min	14 / 11 / 8	16 / 13.5 / 9	21 / 18 / 13
			l/s	233 / 183 / 133	267 / 225 / 150	350 / 300 / 217
	External Pressure	Min/Std/Max	mmAq	0 / 3 / 15	0 / 3 / 15	0 / 3 / 15
			Pa	0 / 29.42 / 147.1	0 / 29.42 / 147.1	0 / 29.42 / 147.1
Fan Motor	Type		-	BLDC	BLDC	BLDC
	Output x n		W	153	153	153
Piping Connections	Liquid Pipe		Type	Flare connection	Flare connection	Flare connection
			Φ, mm (inch)	6.35 (1/4)	6.35 (1/4)	9.52 (3/8)
	Gas Pipe		Type	Flare connection	Flare connection	Flare connection
			Φ, mm (inch)	12.7 (1/2)	12.7 (1/2)	15.88 (5/8)
Drain Pipe		Φ, inch	VP25 (OD 32, ID 25)	VP25 (OD 32, ID 25)	VP25 (OD 32, ID 25)	
Wiring connections	Communication (Min.)		mm <sup>2</sup>	0.75	0.75	0.75
			-	F1, F2	F1, F2	F1, F2
Refrigerant	Type		-	R32	R32	R32
	Control Method		-	EEV	EEV	EEV
Sound	Sound Pressure Level	H/M/L	dB(A)	31 / 28 / 25	32 / 29 / 25	36 / 32 / 27
	Sound Power Level	Cooling		54	57	60
External Dimension	Net Weight		kg	27.0	27.0	27.0
	Shipping Weight		kg	30.5	30.5	30.5
	Net Dimensions (W×H×D)		mm	850 x 250 x 700	850 x 250 x 700	850 x 250 x 700
	Shipping Dimensions (W×H×D)		mm	1,064 x 320 x 784	1,064 x 320 x 784	1,064 x 320 x 784
Casing	Material		-	Steel	Steel	Steel
Additional Accessories	Drain pump	External Model	-	-	-	-
		Internal Model	-	Built in	Built in	Built in
		Max. lifting	mm / Liter/h	750 / 24	750 / 24	750 / 24
	Air Filter		-	-	-	-

### NOTE

- Specification may be subject to change without prior notice.
  - 1) Capacities are based on (Equivalent refrigerant piping 7.5m, Level differences 0m);
    - Cooling : Indoor temperature 27°C DB, 19°C WB / Outdoor temperature 35°C DB, 24°C WB
    - Heating : Indoor temperature 20°C DB, 15°C WB / Outdoor temperature 7°C DB, 6°C WB
  - 2) Sound level was acquired in an anechoic room. Thus actual noise level may be different depending on the installation conditions.
  - 3) These products contain R32 (GWP=675) which is fluorinated greenhouse gas.
  - 4) Select wire size based on the value of MCA

# 1. Specification

## MSP Duct

Model Name			AM090DNMDKG/EU	AM112DNMDKG/EU	AM128DNMDKG/EU
Power Supply			Φ, #, V, Hz	1,2,220~240,50/60	1,2,220~240,50/60
Performance	Capacity	Cooling	kW	9.0	11.2
			Btu/h	30,700	38,200
		Heating	kW	10.0	12.5
			Btu/h	34,100	42,700
Power	Power Input	Cooling	W	135.0	130.0
		Heating		135.0	130.0
	Current Input	Cooling	A	1.2	1.2
		Heating		1.2	1.2
	Current	MCA	A	1.78	1.97
		MFA		15	15
Heat exchanger	Type		-	Fin & Tube	Fin & Tube
	Material	Fin	-	Al	Al
		Tube	-	Cu	Cu
	Fin Treatment		-	hydrophilic	hydrophilic
Fan	Type		-	Sirocco Fan	Sirocco Fan
	Quantity		EA	3	3
	Air Flow Rate	H/M/L	m <sup>3</sup> /min	27 / 22 / 16	30 / 25 / 18
			l/s	450 / 367 / 267	500 / 417 / 300
	External Pressure	Min/Std/Max	mmAq	0 / 4 / 15	0 / 5.2 / 15
			Pa	0 / 39.23 / 147.1	0 / 50.99 / 147.1
Fan Motor	Type		-	BLDC	BLDC
	Output x n		W	153	244
Piping Connections	Liquid Pipe		Type	Flare connection	Flare connection
			Φ, mm (inch)	9.52 (3/8)	9.52 (3/8)
	Gas Pipe		Type	Flare connection	Flare connection
			Φ, mm (inch)	15.88 (5/8)	15.88 (5/8)
Drain Pipe		Φ,inch	VP25 (OD 32,ID 25)	VP25 (OD 32,ID 25)	
Wiring connections	Communication (Min.)		mm <sup>2</sup>	0.75	0.75
			-	F1, F2	F1, F2
Refrigerant	Type		-	R32	R32
	Control Method		-	EEV	EEV
Sound	Sound Pressure Level	H/M/L	dB(A)	37 / 33 / 29	36 / 33 / 30
	Sound Power Level	Cooling		61	61
External Dimension	Net Weight		kg	34.2	39.4
	Shipping Weight		kg	38.9	45.8
	Net Dimensions (W×H×D)		mm	1,200 x 250 x 700	1,300 x 300 x 700
	Shipping Dimensions (W×H×D)		mm	1,429 x 320 x 779	1,529 x 370 x 779
Casing	Material		-	Steel	Steel
Additional Accessories	Drain pump	External Model	-	-	-
		Internal Model	-	Built in	Built in
		Max. lifting	mm / Liter/h	750 / 24	750 / 24
	Air Filter		-	-	-

### NOTE

- Specification may be subject to change without prior notice.
  - 1) Capacities are based on (Equivalent refrigerant piping 7.5m, Level differences 0m);
    - Cooling : Indoor temperature 27°C DB, 19°C WB / Outdoor temperature 35°C DB, 24°C WB
    - Heating : Indoor temperature 20°C DB, 15°C WB / Outdoor temperature 7°C DB, 6°C WB
  - 2) Sound level was acquired in an anechoic room. Thus actual noise level may be different depending on the installation conditions.
  - 3) These products contain R32 (GWP=675) which is fluorinated greenhouse gas.
  - 4) Select wire size based on the value of MCA

# 1. Specification

## MSP Duct

Model Name				AM140DNMDKG/EU	AM160DNMDKG/EU
Power Supply			Φ, #, V, Hz	1,2,220~240,50/60	1,2,220~240,50/60
Performance	Capacity	Cooling	kW	14.0	16.0
			Btu/h	47,800	54,600
		Heating	kW	16.0	18.0
			Btu/h	54,600	61,400
Power	Power Input	Cooling	W	210.0	300.0
		Heating		210.0	300.0
	Current Input	Cooling	A	1.70	2.45
		Heating		1.70	2.45
	Current	MCA	A	2.38	3.60
		MFA		15	15
Heat exchanger	Type		-	Fin & Tube	Fin & Tube
	Material	Fin	-	Al	Al
		Tube	-	Cu	Cu
	Fin Treatment		-	hydrophilic	hydrophilic
Fan	Type		-	Sirocco Fan	Sirocco Fan
	Quantity		EA	3	3
	Air Flow Rate	H/M/L	m <sup>3</sup> /min	40 / 34 / 24	45 / 35 / 25
			l/s	667 / 567 / 400	750 / 583 / 417
	External Pressure	Min/Std/Max	mmAq	0 / 5.2 / 15	0 / 5.2 / 15
			Pa	0 / 50.99 / 147.1	0 / 50.99 / 147.1
Fan Motor	Type		-	BLDC	BLDC
	Output x n		W	244 x 1	350 x 1
Piping Connections	Liquid Pipe		Type	Flare connection	Flare connection
			Φ, mm (inch)	9.52 (3/8)	9.52 (3/8)
	Gas Pipe		Type	Flare connection	Flare connection
			Φ, mm (inch)	15.88 (5/8)	15.88 (5/8)
Drain Pipe		Φ,inch	VP25 (OD 32,ID 25)	VP25 (OD 32,ID 25)	
Wiring connections	Communication (Min.)		mm <sup>2</sup>	0.75	0.75
			-	F1, F2	F1, F2
Refrigerant	Type		-	R32	R32
	Control Method		-	EEV	EEV
Sound	Sound Pressure Level	H/M/L	dB(A)	39 / 36 / 33	43 / 39 / 35
	Sound Power Level	Cooling		64	65
External Dimension	Net Weight		kg	39.4	44.5
	Shipping Weight		kg	45.8	51.1
	Net Dimensions (W×H×D)		mm	1,300 x 300 x 700	1,300 x 300 x 700
	Shipping Dimensions (W×H×D)		mm	1,529 x 370 x 779	1,529 x 370 x 779
Casing	Material		-	Steel	Steel
Additional Accessories	Drain pump	External Model	-	-	-
		Internal Model	-	Built in	Built in
		Max. lifting	mm / Liter/h	750 / 24	750 / 24
	Air Filter		-	-	-

### NOTE

- Specification may be subject to change without prior notice.
  - 1) Capacities are based on (Equivalent refrigerant piping 7.5m, Level differences 0m);
    - Cooling : Indoor temperature 27°C DB, 19°C WB / Outdoor temperature 35°C DB, 24°C WB
    - Heating : Indoor temperature 20°C DB, 15°C WB / Outdoor temperature 7°C DB, 6°C WB
  - 2) Sound level was acquired in an anechoic room. Thus actual noise level may be different depending on the installation conditions.
  - 3) These products contain R32 (GWP=675) which is fluorinated greenhouse gas.
  - 4) Select wire size based on the value of MCA

# 1. Specification

## MSP Duct

Model Name				AM022DNMFKG/EU	AM028DNMFKG/EU	AM036DNMFKG/EU
Power Supply			Φ, #, V, Hz	1,2,220~240,50/60	1,2,220~240,50/60	1,2,220~240,50/60
Performance	Capacity	Cooling	kW	2.2	2.8	3.6
			Btu/h	7,500	9,600	12,300
		Heating	kW	2.5	3.2	4.0
			Btu/h	8,500	10,900	13,600
Power	Power Input	Cooling	W	25.0	30.0	40.0
		Heating		25.0	30.0	40.0
	Current Input	Cooling	A	0.19	0.22	0.29
		Heating		0.19	0.22	0.29
	Current	MCA	A	0.78	0.91	1.04
		MFA		15	15	15
Heat exchanger	Type		-	Fin & Tube	Fin & Tube	Fin & Tube
	Material	Fin	-	Al	Al	Al
		Tube	-	Cu	Cu	Cu
	Fin Treatment		-	hydrophilic	hydrophilic	hydrophilic
Fan	Type		-	Sirocco Fan	Sirocco Fan	Sirocco Fan
	Quantity		EA	3	3	3
	Air Flow Rate	H/M/L	m <sup>3</sup> /min	10 / 9.5 / 9	12.5 / 11 / 10.5	15 / 13 / 12
			l/s	167 / 158 / 150	208 / 183 / 175	250 / 217 / 200
	External Pressure	Min/Std/Max	mmAq	0 / 3 / 15	0 / 3 / 15	0 / 3 / 15
			Pa	0 / 29.42 / 147.1	0 / 29.42 / 147.1	0 / 29.42 / 147.1
Fan Motor	Type		-	BLDC	BLDC	BLDC
	Output x n		W	153	153	153
Piping Connections	Liquid Pipe		Type	Flare connection	Flare connection	Flare connection
			Φ, mm (inch)	6.35 (1/4)	6.35 (1/4)	6.35 (1/4)
	Gas Pipe		Type	Flare connection	Flare connection	Flare connection
			Φ, mm (inch)	12.7 (1/2)	12.7 (1/2)	12.7 (1/2)
Drain Pipe		Φ,inch	VP25 (OD 32,ID 25)	VP25 (OD 32,ID 25)	VP25 (OD 32,ID 25)	
Wiring connections	Communication (Min.)		mm <sup>2</sup>	0.75	0.75	0.75
			-	F1, F2	F1, F2	F1, F2
Refrigerant	Type		-	R32	R32	R32
	Control Method		-	EEV	EEV	EEV
Sound	Sound Pressure Level	H/M/L	dB(A)	33 / 31 / 29	33 / 31 / 29	34 / 31 / 28
	Sound Power Level	Cooling		55	56	57
External Dimension	Net Weight		kg	34.2	34.2	34.2
	Shipping Weight		kg	38.9	38.9	38.9
	Net Dimensions (W×H×D)		mm	1,200 x 250 x 700	1,200 x 250 x 700	1,200 x 250 x 700
	Shipping Dimensions (W×H×D)		mm	1,429 x 320 x 779	1,429 x 320 x 779	1,429 x 320 x 779
Casing	Material		-	Steel	Steel	Steel
Additional Accessories	Drain pump	External Model	-	-	-	-
		Internal Model	-	Built in	Built in	Built in
		Max. lifting	mm / Liter/h	750 / 24	750 / 24	750 / 24
	Air Filter		-	-	-	-

### NOTE

- Specification may be subject to change without prior notice.
  - 1) Capacities are based on (Equivalent refrigerant piping 7.5m, Level differences 0m);
    - Cooling : Indoor temperature 27°C DB, 19°C WB / Outdoor temperature 35°C DB, 24°C WB
    - Heating : Indoor temperature 20°C DB, 15°C WB / Outdoor temperature 7°C DB, 6°C WB
  - 2) Sound level was acquired in an anechoic room. Thus actual noise level may be different depending on the installation conditions.
  - 3) These products contain R32 (GWP=675) which is fluorinated greenhouse gas.
  - 4) Select wire size based on the value of MCA

# 1. Specification

## MSP Duct

Model Name				AM045DNMFKG/EU	AM056DNMFKG/EU	AM071DNMFKG/EU
Power Supply			Φ, #, V, Hz	1,2,220~240,50/60	1,2,220~240,50/60	1,2,220~240,50/60
Performance	Capacity	Cooling	kW	4.5	5.6	7.1
			Btu/h	15,400	19,100	24,200
		Heating	kW	5.0	6.3	8.0
			Btu/h	17,100	21,500	27,300
Power	Power Input	Cooling	W	50.0	90.0	135.0
		Heating		50.0	90.0	135.0
	Current Input	Cooling	A	0.37	0.66	0.98
		Heating		0.37	0.66	0.98
	Current	MCA	A	1.22	1.45	2.17
		MFA		15	15	15
Heat exchanger	Type		-	Fin & Tube	Fin & Tube	Fin & Tube
	Material	Fin	-	Al	Al	Al
		Tube	-	Cu	Cu	Cu
	Fin Treatment		-	hydrophilic	hydrophilic	hydrophilic
Fan	Type		-	Sirocco Fan	Sirocco Fan	Sirocco Fan
	Quantity		EA	3	3	3
	Air Flow Rate	H/M/L	m <sup>3</sup> /min	18.5 / 16 / 13.5	24 / 21.5 / 18.5	32 / 28.5 / 24.5
			l/s	308 / 267 / 225	400 / 358 / 308	533 / 475 / 408
	External Pressure	Min/Std/Max	mmAq	0 / 3 / 15	0 / 5.2 / 15	0 / 5.2 / 15
			Pa	0 / 29.42 / 147.1	0 / 51.0 / 147.1	0 / 51.0 / 147.1
Fan Motor	Type		-	BLDC	BLDC	BLDC
	Output x n		W	153	244	244
Piping Connections	Liquid Pipe		Type	Flare connection	Flare connection	Flare connection
			Φ, mm (inch)	6.35 (1/4)	6.35 (1/4)	9.52 (3/8)
	Gas Pipe		Type	Flare connection	Flare connection	Flare connection
			Φ, mm (inch)	12.7 (1/2)	12.7 (1/2)	15.88 (5/8)
Drain Pipe		Φ, inch	VP25 (OD 32, ID 25)	VP25 (OD 32, ID 25)	VP25 (OD 32, ID 25)	
Wiring connections	Communication (Min.)		mm <sup>2</sup>	0.75	0.75	0.75
			-	F1, F2	F1, F2	F1, F2
Refrigerant	Type		-	R32	R32	R32
	Control Method		-	EEV	EEV	EEV
Sound	Sound Pressure Level	H/M/L	dB(A)	34 / 31 / 28	38 / 35 / 31	39 / 35 / 30
	Sound Power Level	Cooling		57	63	63
External Dimension	Net Weight		kg	34.2	39.4	39.4
	Shipping Weight		kg	38.9	45.8	45.8
	Net Dimensions (W×H×D)		mm	1,200 x 250 x 700	1,300 x 300 x 700	1,300 x 300 x 700
	Shipping Dimensions (W×H×D)		mm	1,429 x 320 x 779	1,529 x 370 x 779	1,529 x 370 x 779
Casing	Material		-	Steel	Steel	Steel
Additional Accessories	Drain pump	External Model	-	-	-	-
		Internal Model	-	Built in	Built in	Built in
		Max. lifting	mm / Liter/h	750 / 24	750 / 24	750 / 24
	Air Filter		-	-	-	-

### NOTE

- Specification may be subject to change without prior notice.
  - 1) Capacities are based on (Equivalent refrigerant piping 7.5m, Level differences 0m);
    - Cooling : Indoor temperature 27°C DB, 19°C WB / Outdoor temperature 35°C DB, 24°C WB
    - Heating : Indoor temperature 20°C DB, 15°C WB / Outdoor temperature 7°C DB, 6°C WB
  - 2) Sound level was acquired in an anechoic room. Thus actual noise level may be different depending on the installation conditions.
  - 3) These products contain R32 (GWP=675) which is fluorinated greenhouse gas.
  - 4) Select wire size based on the value of MCA

## 2. Summary Table

### MSP Duct

#### Performance Characteristics

Model Code	Fan Speed	Nominal Capacity [kW]			Airflow [CMM]	Sound Pressure [dBA]	Sound Power [dBA]	Static Pressure (Min/Std/Max) [mmAq]
		Cooling	Sensible	Heating				
AM022DNMDKG/EU	High	2.2	1.5	2.5	10.5	28	50	0 / 2.5 / 15
	Mid	1.9	1.3	2.3	9	26	-	
	Low	1.5	1.0	2.0	7	24	-	
AM028DNMDKG/EU	High	2.8	1.9	3.2	10.5	28	51	0 / 2.5 / 15
	Mid	2.4	1.6	3.0	9	26	-	
	Low	1.9	1.3	2.6	7	24	-	
AM036DNMDKG/EU	High	3.6	2.6	4.0	12	30	53	0 / 2.5 / 15
	Mid	2.9	2.1	3.6	9.5	27	-	
	Low	2.3	1.7	3.2	7.5	24	-	
AM045DNMDKG/EU	High	4.5	3.3	5.0	14	31	54	0 / 3 / 15
	Mid	3.6	2.6	4.4	11	28	-	
	Low	2.6	1.9	3.8	8	25	-	
AM056DNMDKG/EU	High	5.6	4.2	6.3	16	32	57	0 / 3 / 15
	Mid	4.8	3.6	5.8	13.5	29	-	
	Low	3.2	2.4	4.7	9	25	-	
AM071DNMDKG/EU	High	7.1	5.4	8.0	21	36	60	0 / 3 / 15
	Mid	6.2	4.7	7.4	18	32	-	
	Low	4.5	3.4	6.3	13	27	-	
AM090DNMDKG/EU	High	9.0	7.1	10.0	27	37	61	0 / 4 / 15
	Mid	7.5	5.9	9.0	22	33	-	
	Low	5.5	4.3	7.7	16	29	-	
AM112DNMDKG/EU	High	11.2	8.6	12.5	30	36	61	0 / 5.2 / 15
	Mid	9.5	7.3	11.4	25	33	-	
	Low	6.9	5.3	9.7	18	30	-	
AM128DNMDKG/EU	High	12.8	9.9	13.8	36	37	62	0 / 5.2 / 15
	Mid	10.9	8.4	12.6	30	34	-	
	Low	8.4	6.5	11.0	23	31	-	
AM140DNMDKG/EU	High	14.0	10.8	16.0	40	39	64	0 / 5.2 / 15
	Mid	12.1	9.3	14.8	34	36	-	
	Low	8.6	6.6	12.4	24	33	-	
AM160DNMDKG/EU	High	16.0	12.1	18.0	45	43	65	0 / 5.2 / 15
	Mid	12.8	9.7	15.9	35	39	-	
	Low	9.1	6.9	13.4	25	35	-	

## 2. Summary Table

### MSP Duct

#### Performance Characteristics

Model Code	Fan Speed	Nominal Capacity [kW]			Airflow [CMM]	Sound Pressure [dBA]	Sound Power [dBA]	Static Pressure (Min/Std/Max) [mmAq]
		Cooling	Sensible	Heating				
AM022DNMFKG/EU	High	2.2	2.1	2.5	10.0	33	55	0 / 3 / 15
	Mid	2.1	2.0	2.4	9.5	31	-	
	Low	2.0	1.9	2.4	9.0	29	-	
AM028DNMFKG/EU	High	2.8	2.7	3.2	12.5	33	56	0 / 3 / 15
	Mid	2.5	2.4	3.0	11.0	31	-	
	Low	2.4	2.3	2.9	10.5	29	-	
AM036DNMFKG/EU	High	3.6	3.4	4.0	15.0	34	57	0 / 3 / 15
	Mid	3.2	3.0	3.7	13.0	31	-	
	Low	3.0	2.8	3.6	12.0	28	-	
AM045DNMFKG/EU	High	4.5	4.2	5.0	18.5	34	57	0 / 3 / 15
	Mid	4.0	3.7	4.6	16.0	31	-	
	Low	3.4	3.2	4.3	13.5	28	-	
AM056DNMFKG/EU	High	5.6	5.3	6.3	24.0	38	63	0 / 5.2 / 15
	Mid	5.1	4.8	6.0	21.5	35	-	
	Low	4.4	4.2	5.5	18.5	31	-	
AM071DNMFKG/EU	High	7.1	6.7	8.0	32.0	39	63	0 / 5.2 / 15
	Mid	6.4	6.0	7.5	28.5	35	-	
	Low	5.6	5.3	7.0	24.5	30	-	

#### NOTE

- Sound data is based on cooling operation.

#### Electric Characteristics

Model Code	Power Supply (Φ, #, V, Hz)	Power Input (W)	Current Input (A)	MCA (A)	MFA (A)	FLA (A)
AM022DNMDKG/EU	1,2,220~240,50/60	42	0.4	0.67	15	0.54
AM028DNMDKG/EU		42	0.4	0.67	15	0.54
AM036DNMDKG/EU		45	0.4	0.81	15	0.64
AM045DNMDKG/EU		55	0.5	0.89	15	0.71
AM056DNMDKG/EU		70	0.6	1.08	15	0.86
AM071DNMDKG/EU		110	1.0	1.48	15	1.19
AM090DNMDKG/EU		135	1.2	1.78	15	1.42
AM112DNMDKG/EU		130	1.2	1.97	15	1.57
AM128DNMDKG/EU		160	1.4	2.17	15	1.74
AM140DNMDKG/EU		210	1.7	2.38	15	1.90
AM160DNMDKG/EU		300	2.45	3.60	15	2.88
AM022DNMFKG/EU		25	0.19	0.78	15	0.62
AM028DNMFKG/EU		30	0.22	0.91	15	0.73
AM036DNMFKG/EU		40	0.29	1.04	15	0.83
AM045DNMFKG/EU		50	0.37	1.22	15	0.98
AM056DNMFKG/EU		90	0.66	1.45	15	1.16
AM071DNMFKG/EU		135	0.98	2.17	15	1.74

#### NOTE

- MCA : Minimum circuit amperes
- MFA : Maximum fuse amperes
- Select wire size based on the value of MCA

# 3. Capacity Table

## MSP Duct

### DELUXE

#### Cooling

TC : Total Capacity, SHC : Sensible Heat Capacity

Capacity Index	Outdoor Air Temp. (°C, DB)	Indoor temperature													
		20(°C, DB)		23(°C, DB)		26(°C, DB)		27(°C, DB)		28(°C, DB)		30(°C, DB)		32(°C, DB)	
		14(°C, WB)		16(°C, WB)		18(°C, WB)		19(°C, WB)		20(°C, WB)		22(°C, WB)		24(°C, WB)	
		TC	SHC	TC	SHC	TC	SHC	TC	SHC	TC	SHC	TC	SHC	TC	SHC
022	35	1.5	1.2	1.8	1.4	2.1	1.6	2.2	1.6	2.3	1.6	2.4	1.6	2.6	1.5
028	35	1.9	1.6	2.3	1.8	2.6	1.9	2.8	2.0	2.9	2.0	3.1	2.0	3.3	1.9
036	35	2.5	2.0	2.9	2.3	3.4	2.5	3.6	2.6	3.7	2.6	4.0	2.6	4.2	2.4
045	35	3.1	2.7	3.7	3.1	4.2	3.2	4.5	3.3	4.7	3.3	5.0	3.3	5.3	3.1
056	35	3.9	3.3	4.6	3.8	5.3	4.0	5.6	4.2	5.8	4.2	6.2	4.2	6.6	4.0
071	35	4.9	4.3	5.8	5.0	6.7	5.2	7.1	5.4	7.4	5.6	7.9	5.6	8.4	5.3
090	35	6.2	5.7	7.3	6.5	8.4	6.9	9.0	7.1	9.3	7.2	10.0	7.2	10.6	7.0
112	35	7.7	6.8	9.1	7.7	10.5	8.2	11.2	8.6	11.6	8.8	12.4	8.7	13.2	8.5
128	35	8.8	7.8	10.4	8.9	12.0	9.5	12.8	9.9	13.3	9.9	14.2	9.9	15.1	9.7
140	35	9.7	8.6	11.4	9.7	13.1	10.5	14.0	10.8	14.5	10.8	15.5	10.8	16.5	10.6
160	35	11.1	9.6	13.0	10.9	15.0	11.8	16.0	12.1	16.6	12.1	17.7	12.1	18.9	11.9

#### Heating

TC : Total Capacity (kW)

Capacity Index	Outdoor Air Temp. (°C)		Indoor temperature (°C, DB)						
			14(°C, DB)	16(°C, DB)	18(°C, DB)	20(°C, DB)	22(°C, DB)	24(°C, DB)	27(°C, DB)
			TC	TC	TC	TC	TC	TC	TC
	DB	WB	kW	kW	kW	kW	kW	kW	kW
022	7.0	6.0	2.8	2.7	2.5	2.3	2.2	2.2	2.2
028	7.0	6.0	3.3	3.2	3.2	3.0	2.7	2.7	2.6
036	7.0	6.0	4.3	4.1	4.1	4.0	3.7	3.4	3.2
045	7.0	6.0	5.4	5.1	5.1	5.0	4.6	4.2	3.9
056	7.0	6.0	6.9	6.5	6.4	6.3	5.8	5.3	4.9
071	7.0	6.0	8.6	8.2	8.1	8.0	7.4	6.8	6.4
090	7.0	6.0	10.9	10.3	10.1	10.0	9.2	8.4	7.8
112	7.0	6.0	13.6	12.9	12.7	12.5	11.5	10.6	9.9
128	7.0	6.0	15.0	14.2	14.0	13.8	12.7	11.7	10.9
140	7.0	6.0	17.4	16.5	16.2	16.0	14.8	13.5	12.6
160	7.0	6.0	18.8	18.6	18.2	18.0	16.7	15.2	14.5

#### NOTE

- The performance table shows the average value of each conditions.

# 3. Capacity Table

## MSP Duct

### FLAGSHIP

#### Cooling

TC : Total Capacity, SHC : Sensible Heat Capacity

Capacity Index	Outdoor Air Temp. (°C, DB)	Indoor temperature													
		20(°C,DB)		23(°C,DB)		26(°C,DB)		27(°C,DB)		28(°C,DB)		30(°C,DB)		32(°C,DB)	
		14(°C,WB)		16(°C,WB)		18(°C,WB)		19(°C,WB)		20(°C,WB)		22(°C,WB)		24(°C,WB)	
		TC	SHC	TC	SHC	TC	SHC	TC	SHC	TC	SHC	TC	SHC	TC	SHC
022	35	1.1	1.1	1.5	1.5	2.0	2.0	2.2	2.1	2.3	2.1	2.6	2.3	2.9	2.4
028	35	1.4	1.4	2.0	2.0	2.5	2.5	2.8	2.7	3.0	2.8	3.3	2.9	3.6	3.0
036	35	1.8	1.8	2.5	2.5	3.2	3.1	3.6	3.4	3.8	3.5	4.2	3.6	4.7	3.8
045	35	2.3	2.3	3.2	3.2	4.1	3.9	4.5	4.2	4.8	4.3	5.3	4.5	5.9	4.7
056	35	2.8	2.8	3.9	3.9	5.0	4.9	5.6	5.3	5.9	5.4	6.6	5.7	7.3	5.9
071	35	3.6	3.6	5.0	5.0	6.4	6.2	7.1	6.7	7.5	6.9	8.4	7.2	9.2	7.4

#### Heating

TC : Total Capacity (kW)

Capacity Index	Outdoor Air Temp. (°C)		Indoor temperature (°C, DB)						
			14(°C,DB)	16(°C,DB)	18(°C,DB)	20(°C,DB)	22(°C,DB)	24(°C,DB)	27(°C,DB)
			TC	TC	TC	TC	TC	TC	TC
	DB	WB	kW	kW	kW	kW	kW	kW	kW
022	7.0	6.0	3.0	2.8	2.7	2.5	2.3	2.0	1.6
028	7.0	6.0	3.8	3.6	3.4	3.2	2.9	2.6	2.1
036	7.0	6.0	4.7	4.5	4.2	4.0	3.6	3.2	2.6
045	7.0	6.0	5.9	5.6	5.3	5.0	4.5	4.0	3.3
056	7.0	6.0	7.4	7.1	6.7	6.3	5.7	5.0	4.1
071	7.0	6.0	9.4	9.0	8.5	8.0	7.2	6.4	5.2

#### NOTE

- The performance table shows the average value of each conditions.

# 4. Dimensional Drawing

## MSP Duct

AM022DNMDKG/EU, AM028DNMDKG/EU, AM036DNMDKG/EU, AM045DNMDKG/EU  
 AM056DNMDKG/EU, AM071DNMDKG/EU

Units : mm [inches]

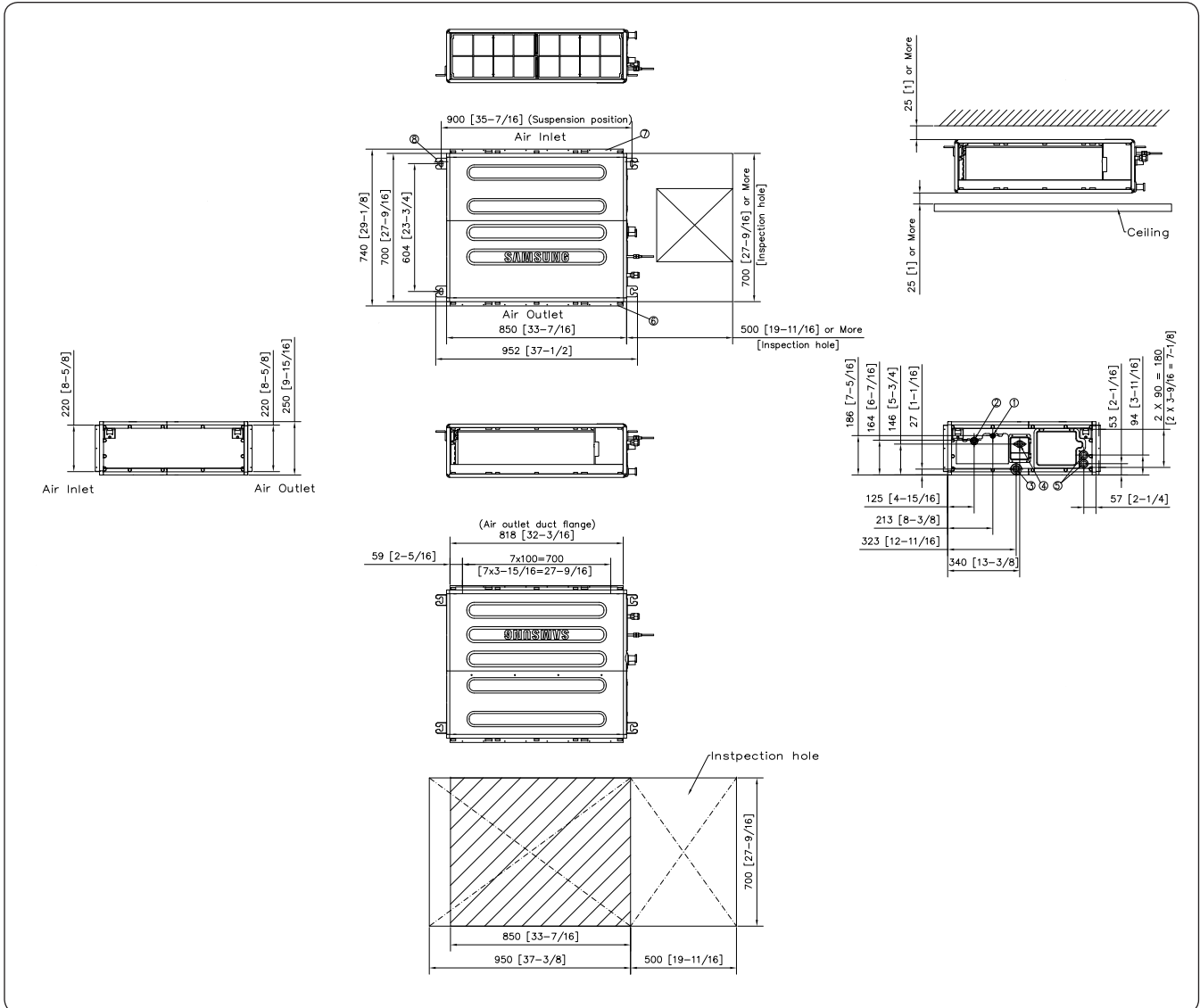

No.	Name	Description	
		AM022DNMDKG/EU, AM028DNMDKG/EU, AM036DNMDKG/EU, AM045DNMDKG/EU, AM056DNMDKG/EU	AM071DNMDKG/EU
①	Liquid pipe connection	Ø6.35 (1/4)	Ø9.52 (3/8)
②	Gas pipe connection	Ø12.70 (1/2)	Ø15.88 (5/8)
③	Drain pipe connection (Without drain pump)	VP25 (OD 32, ID 25)	
④	Drain pipe connection (With drain pump)	-	
⑤	Power & Communication Conduits	-	
⑥	Air discharge grille flange	-	
⑦	Return Air Side	-	
⑧	Hook	Ø9.52 or M10	

# 4. Dimensional Drawing

## MSP Duct

AM090DNMDKG/EU, AM022DNMFKG/EU, AM028DNMFKG/EU, AM036DNMFKG/EU  
AM045DNMFKG/EU

Units : mm [inches]

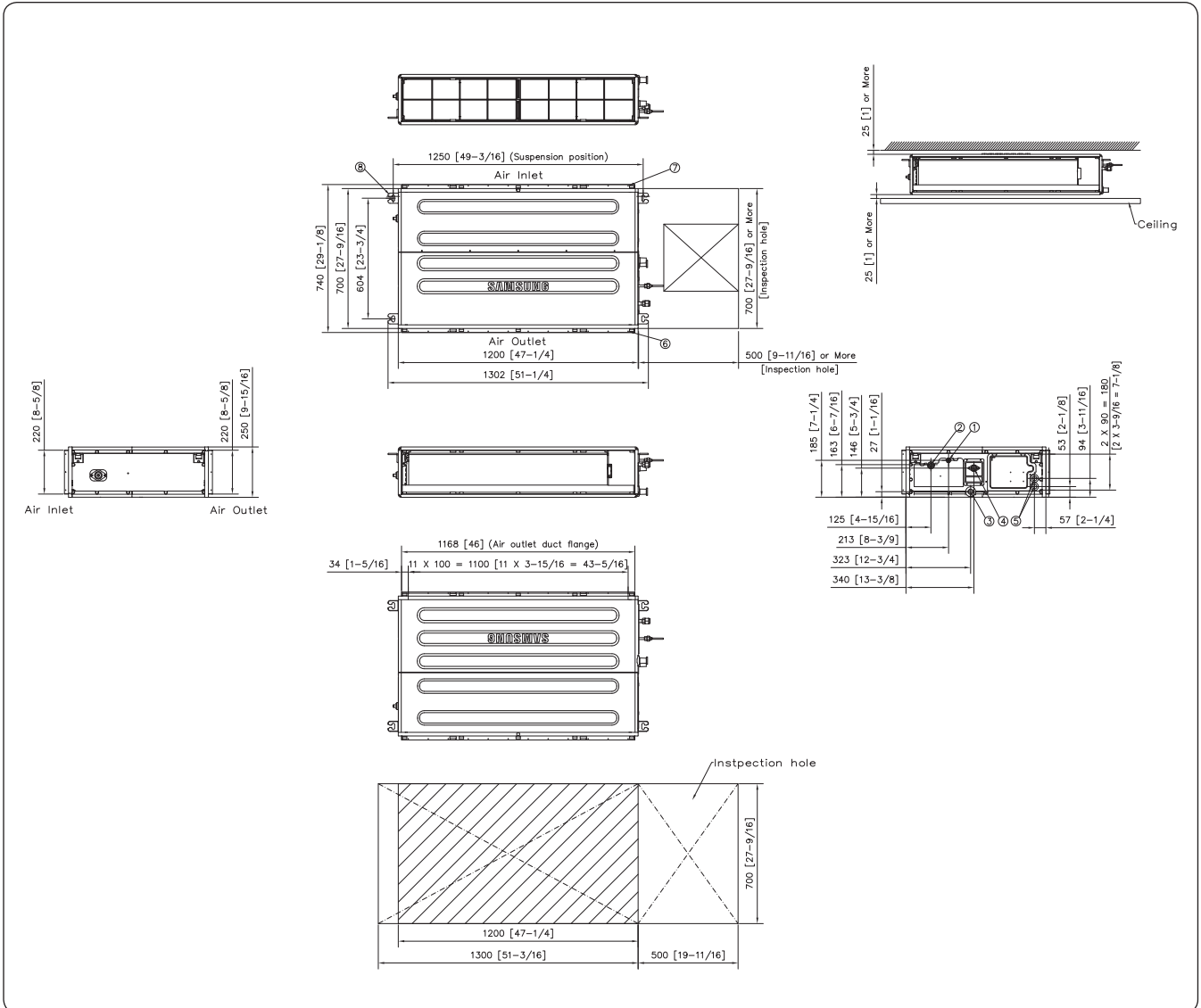

No.	Name	Description	
		AM022DNMFKG/EU, AM028DNMFKG/EU, AM036DNMFKG/EU, AM045DNMFKG/EU	AM090DNMDKG/EU
①	Liquid pipe connection	Ø6.35 (1/4)	Ø9.52 (3/8)
②	Gas pipe connection	Ø12.70 (1/2)	Ø15.88 (5/8)
③	Drain pipe connection (Without drain pump)	VP25 (OD 32, ID 25)	
④	Drain pipe connection (With drain pump)	-	
⑤	Power & Communication Conduits	-	
⑥	Air discharge grille flange	-	
⑦	Return Air Side	-	
⑧	Hook	Ø9.52 or M10	

# 4. Dimensional Drawing

## MSP Duct

AM112DNMDKG/EU, AM128DNMDKG/EU, AM140DNMDKG/EU, AM160DNMDKG/EU  
 AM056DNMFKG/EU, AM071DNMFKG/EU

Units : mm [inches]

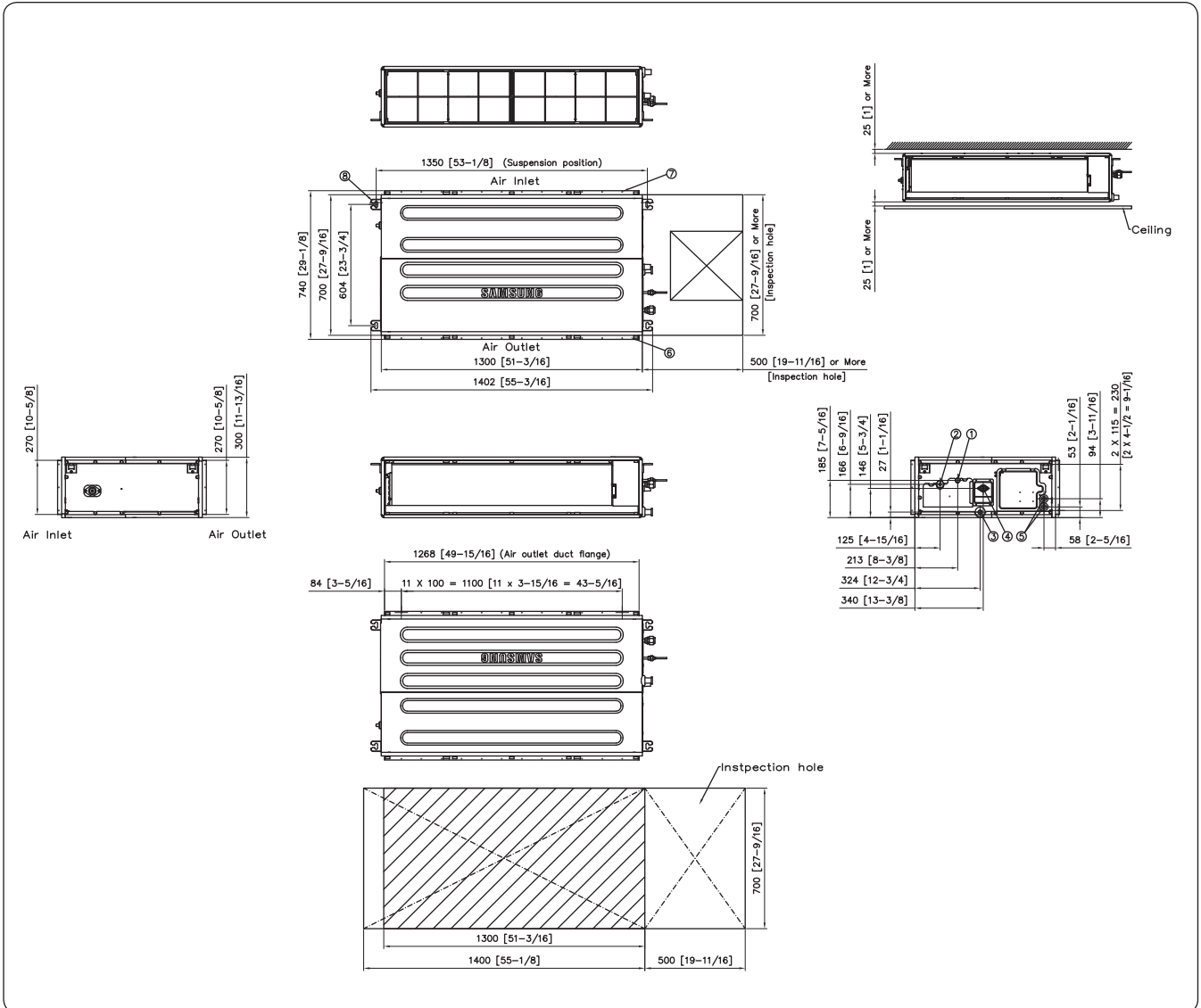

No.	Name	Description	
		AM056DNMFKG/EU	AM112DNMDKG/EU, AM128DNMDKG/EU, AM140DNMDKG/EU, AM160DNMDKG/EU, AM071DNMFKG/EU
①	Liquid pipe connection	Ø6.35 (1/4)	Ø9.52 (3/8)
②	Gas pipe connection	Ø12.70 (1/2)	Ø15.88 (5/8)
③	Drain pipe connection (Without drain pump)		VP25 (OD 32, ID 25)
④	Drain pipe connection (With drain pump)		-
⑤	Power & Communication Conduits		-
⑥	Air discharge grille flange		-
⑦	Return Air Side		-
⑧	Hook		Ø9.52 or M10

# 5. Center of Gravity

## MSP Duct

Units : mm [inches]

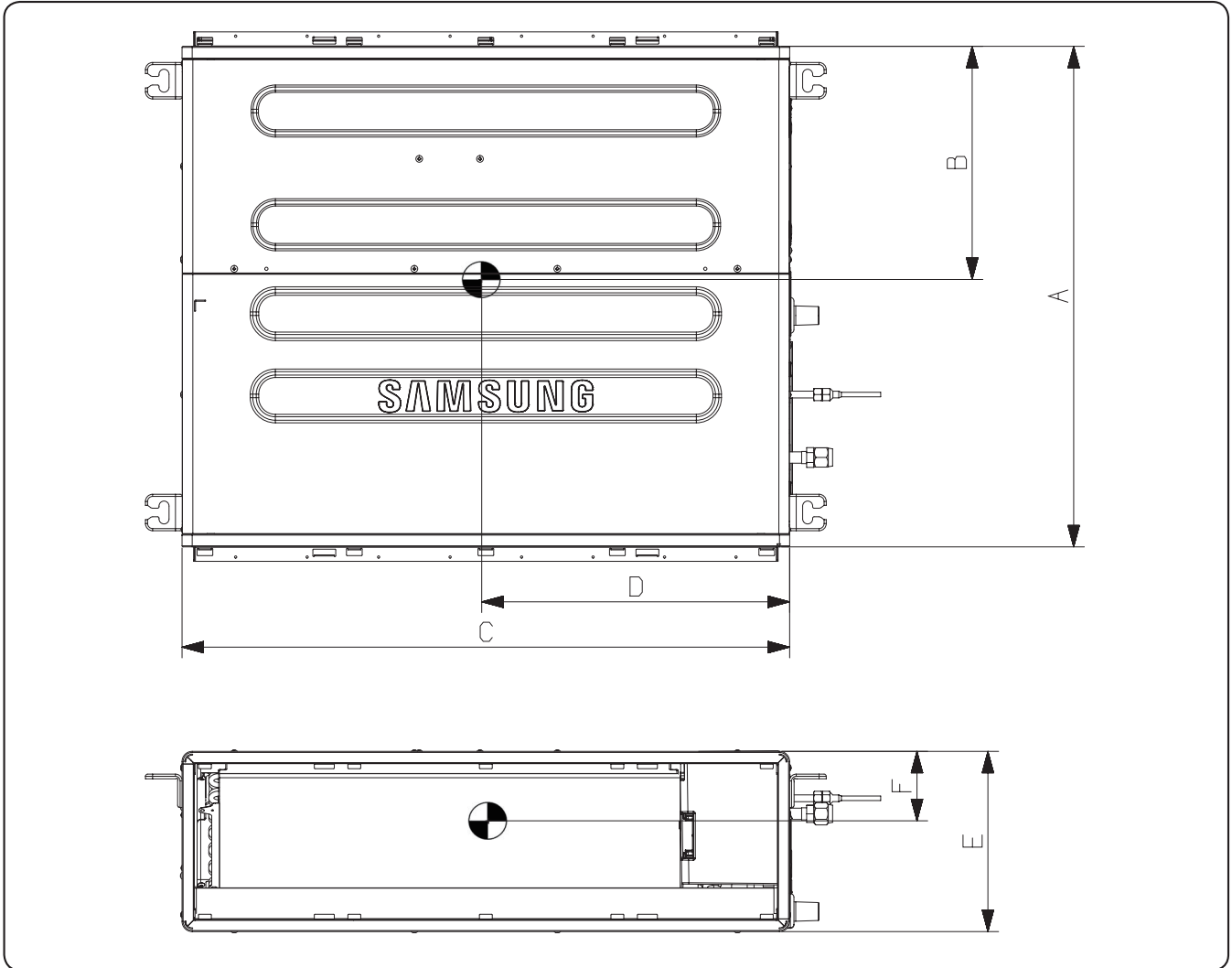

Model	A	B	C	D	E	F
AM022DNMDKG/EU, AM028DNMDKG/EU AM036DNMDKG/EU, AM045DNMDKG/EU AM056DNMDKG/EU, AM071DNMDKG/EU	700 [27-9/16]	335 [14]	900 [35-7/16]	405 [15-15/16]	250 [9-13/16]	125 [4-15/16]
AM090DNMDKG/EU, AM022DNMFKG/EU AM028DNMFKG/EU, AM036DNMFKG/EU AM045DNMFKG/EU	700 [27-9/16]	265 [10-7/16]	1200 [47-1/4]	540 [21-17/64]	250 [9-13/16]	125 [4-15/16]
AM112DNMDKG/EU, AM128DNMDKG/EU AM140DNMDKG/EU, AM160DNMDKG/EU AM056DNMFKG/EU, AM071DNMFKG/EU	700 [27-9/16]	265 [10-7/16]	1300 [51-3/16]	625 [24-39/64]	300 [11-13/16]	150 [5-15/16]

# 6. Electrical Wiring Diagram

## MSP Duct

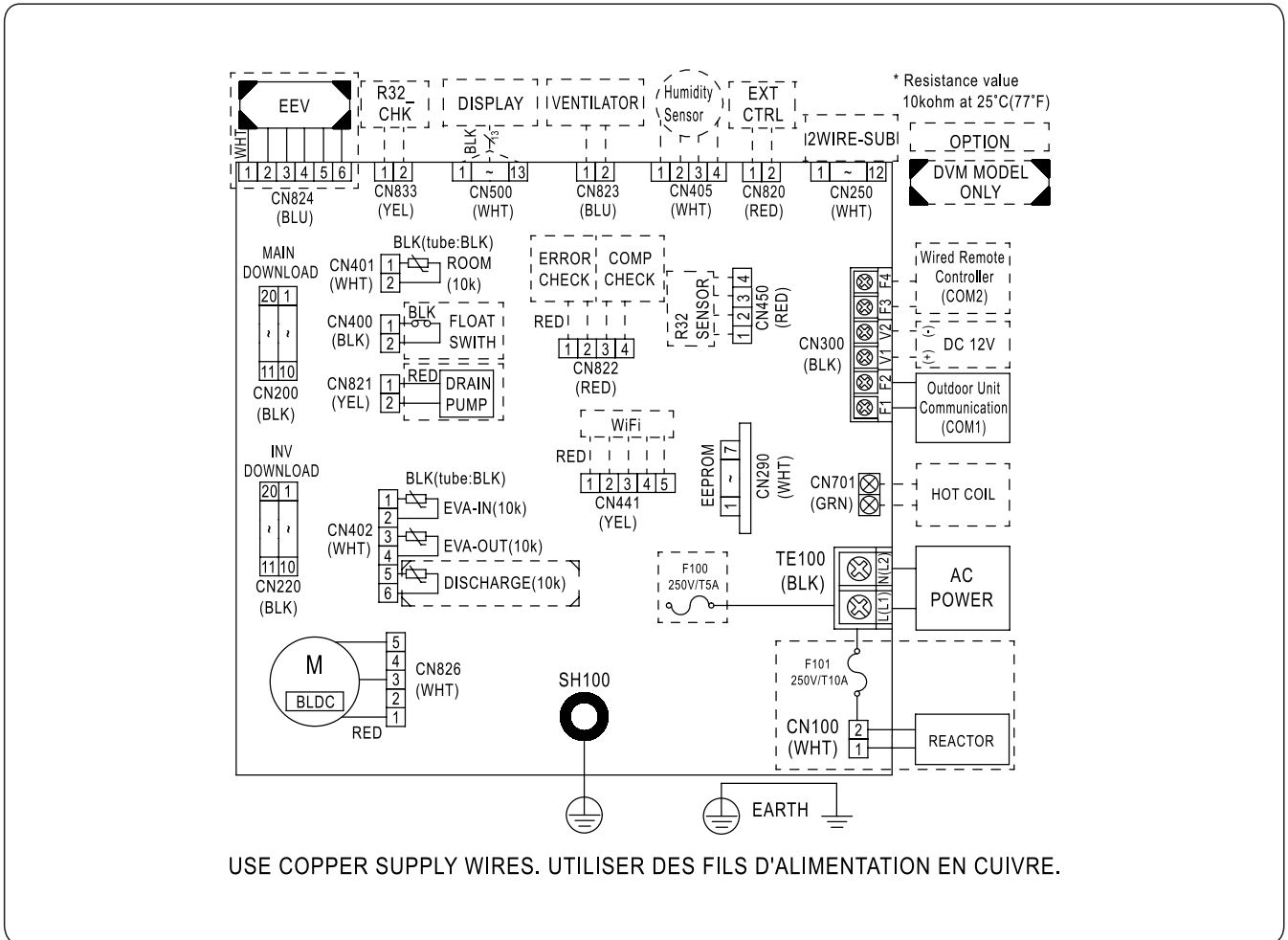

EEV	Electronic Expansion Valve	EVA-IN(10K)	Thermistor - IDU heat exchanger In	DISCHARGE(10K)	Thermistor - Indoor Discharge Air
M-BLDC	Motor for Indoor Fan	EVA-OUT(10K)	Thermistor - IDU heat exchanger Out	EXT CTRL	External Control
ROOM(10K)	Thermistor - Indoor Room				

### NOTE

- This wiring diagram applies only to the Indoor unit.
- Symbols show as follow :  
blk: black, red: red, blu: blue, wht: white, yel: yellow, brn: brown, sky: skyblue: grn: green
- For connection wiring indoor-outdoor transmission F1-F2, indoor-wired remote controller transmission F3-F4.
- Protective earth(screw), : connector, : The wire quantity

# 7. Sound Data

## MSP Duct

### Sound pressure level

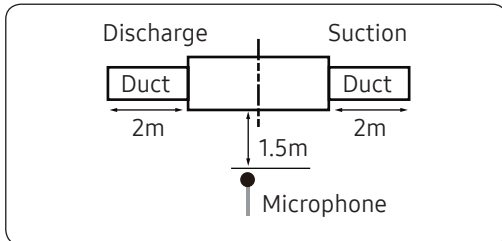

Unit: dB(A)

MODEL	High	Mid	Low
AM022DNMDKG/EU	28	26	24
AM028DNMDKG/EU	28	26	24
AM036DNMDKG/EU	30	27	24
AM045DNMDKG/EU	31	28	25

• NR Curve

1) AM022DNMDKG/EU

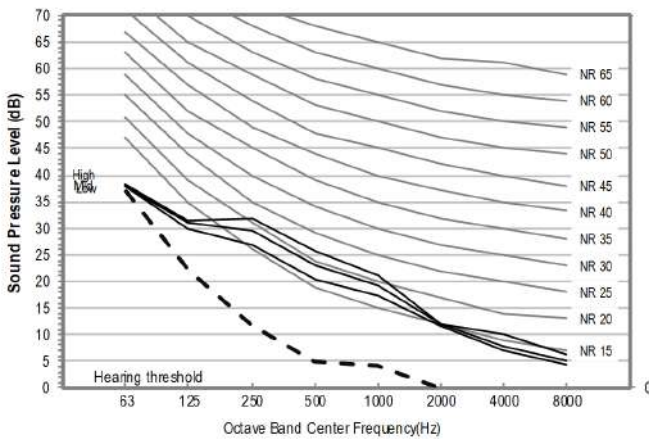

2) AM028DNMDKG/EU

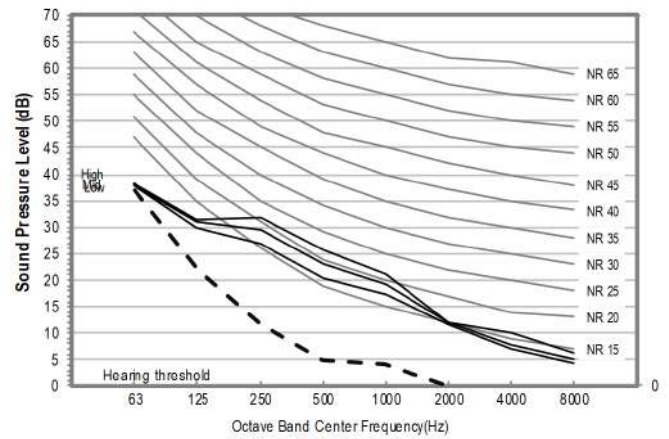

3) AM036DNMDKG/EU

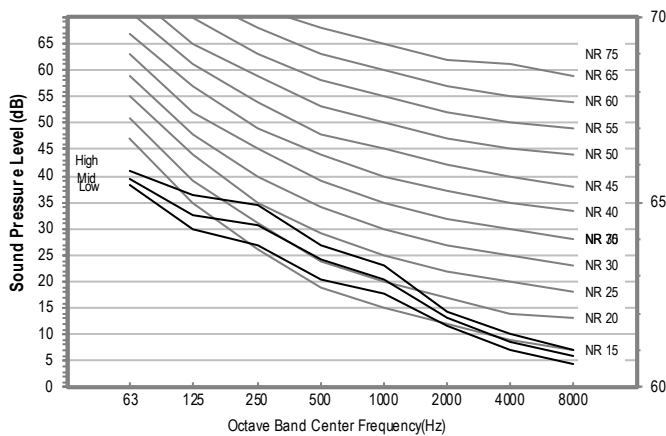

4) AM045DNMDKG/EU

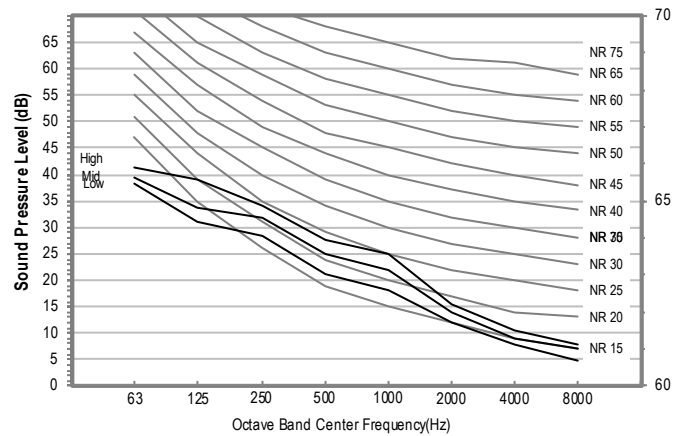

**NOTE**

- Specifications may be subject to change without prior notice.
  - Sound pressure level is obtained in an anechoic room.
  - Sound pressure level is a relative value, depending on the distance and acoustic environment.
  - Sound pressure level may differ depending on operation condition.
  - dBA = A weighted sound pressure level
  - Reference acoustic pressure 0 dB = 20μPa

# 7. Sound Data

## MSP Duct

### Sound pressure level

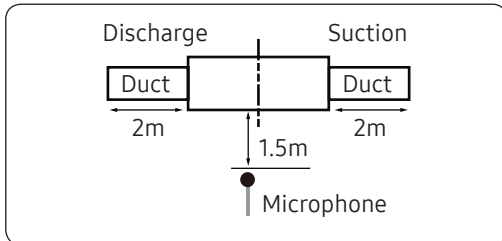

Unit: dB(A)

MODEL	High	Mid	Low
AM056DNMDKG/EU	32	29	25
AM071DNMDKG/EU	36	32	27
AM090DNMDKG/EU	37	33	29
AM112DNMDKG/EU	36	33	30

- NR Curve

1) AM056DNMDKG/EU

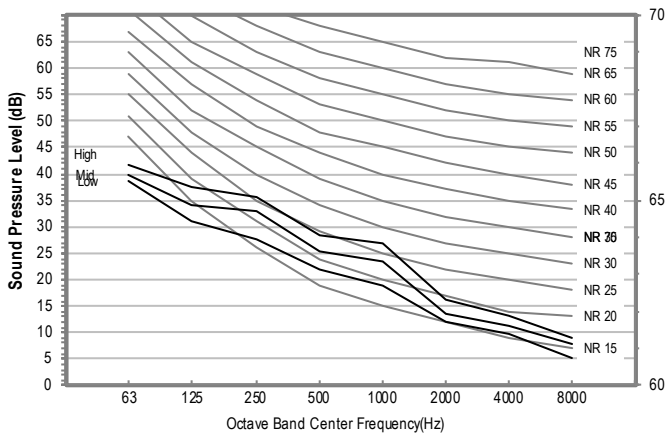

2) AM071DNMDKG/EU

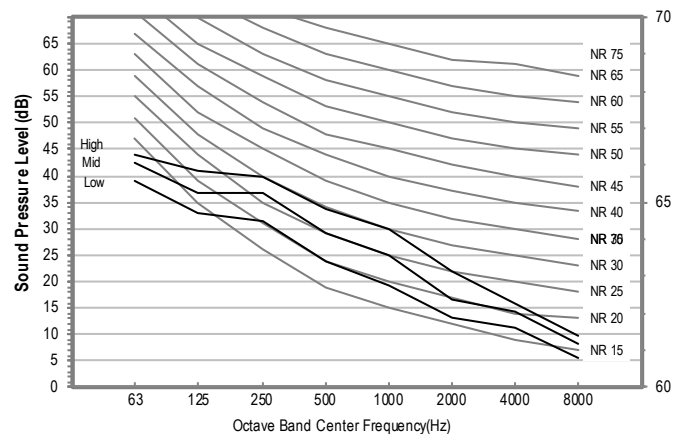

3) AM090DNMDKG/EU

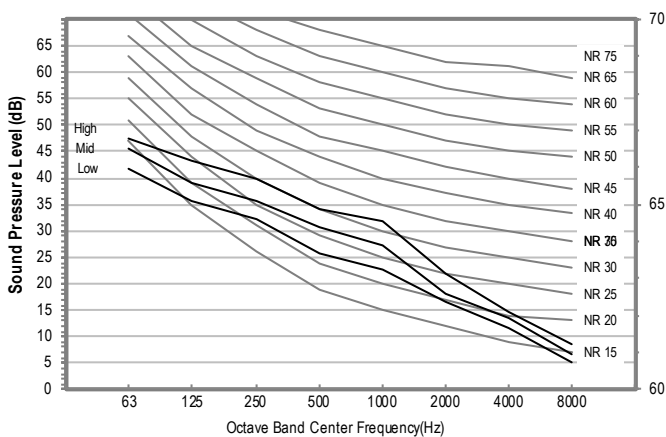

4) AM112DNMDKG/EU

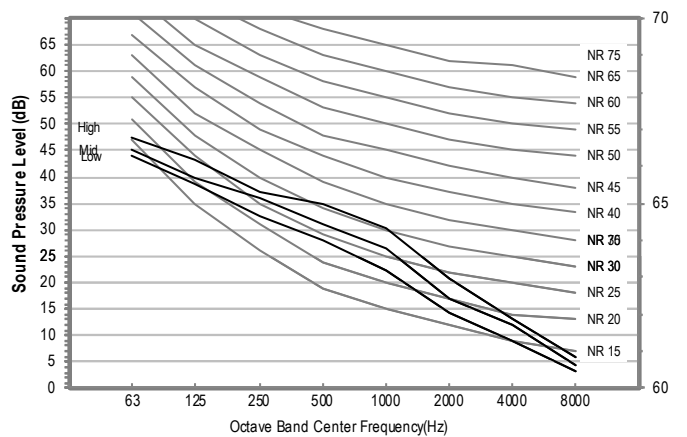

### NOTE

- Specifications may be subject to change without prior notice.
  - Sound pressure level is obtained in an anechoic room.
  - Sound pressure level is a relative value, depending on the distance and acoustic environment.
  - Sound pressure level may differ depending on operation condition.
  - dB(A) = A weighted sound pressure level
  - Reference acoustic pressure 0 dB = 20μPa

# 7. Sound Data

## MSP Duct

### Sound pressure level

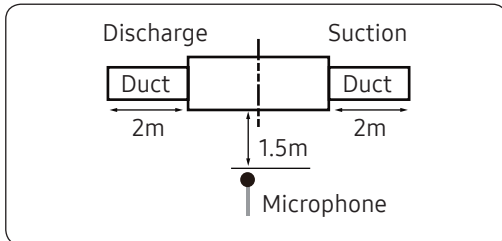

Unit: dB(A)

MODEL	High	Mid	Low
AM128DNMDKG/EU	37	34	31
AM140DNMDKG/EU	39	36	33
AM160DNMDKG/EU	43	39	35

- NR Curve

1) AM128DNMDKG/EU

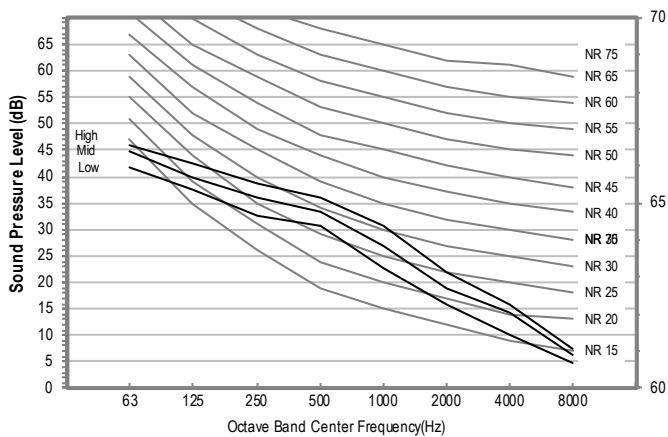

2) AM140DNMDKG/EU

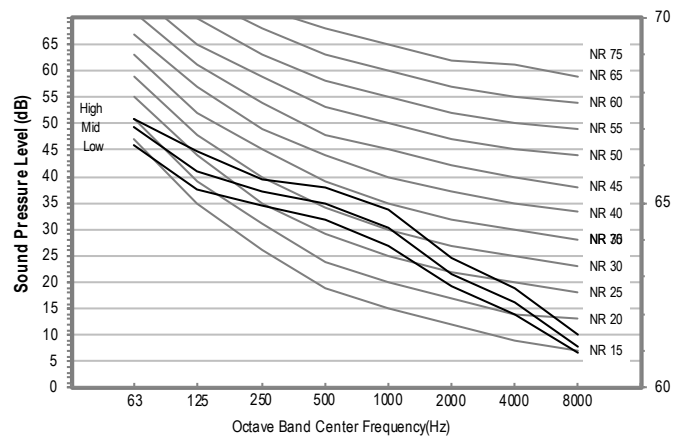

3) AM160DNMDKG/EU

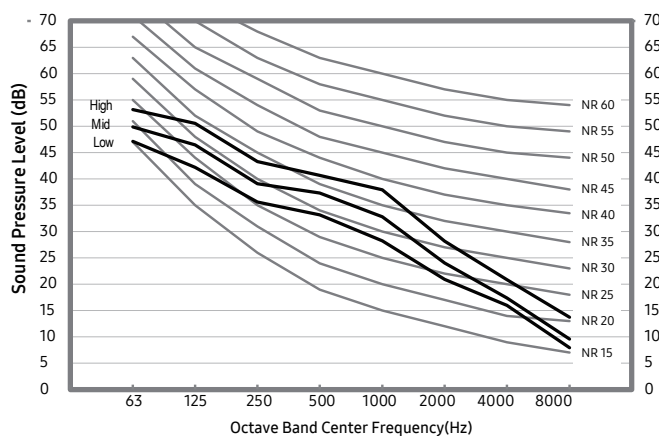

### NOTE

- Specifications may be subject to change without prior notice.
  - Sound pressure level is obtained in an anechoic room.
  - Sound pressure level is a relative value, depending on the distance and acoustic environment.
  - Sound pressure level may differ depending on operation condition.
  - dB(A) = A weighted sound pressure level
  - Reference acoustic pressure 0 dB = 20μPa

# 7. Sound Data

## MSP Duct

### Sound pressure level

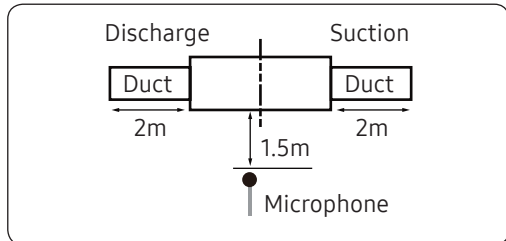

Unit: dB(A)

MODEL	High	Mid	Low
AM022DNMFKG/EU	33	31	29
AM028DNMFKG/EU	33	31	29
AM036DNMFKG/EU	34	31	28
AM045DNMFKG/EU	34	31	28

- NR Curve

1) AM022DNMFKG/EU

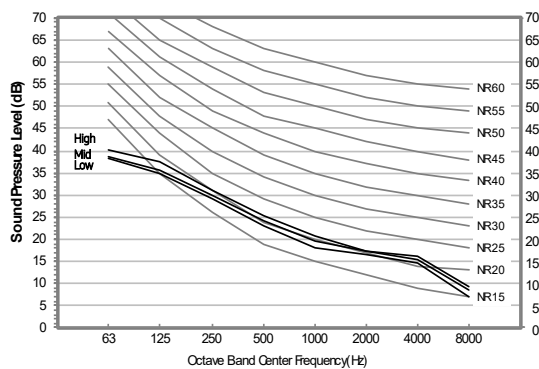

2) AM028DNMFKG/EU

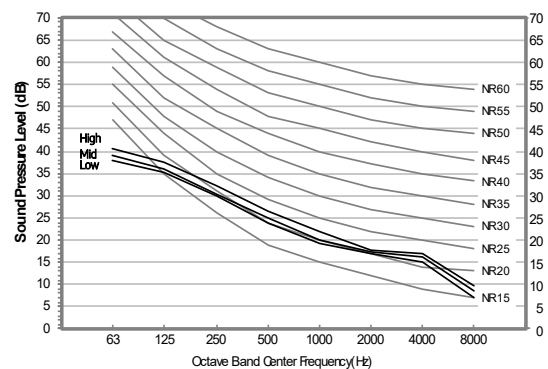

3) AM036DNMFKG/EU

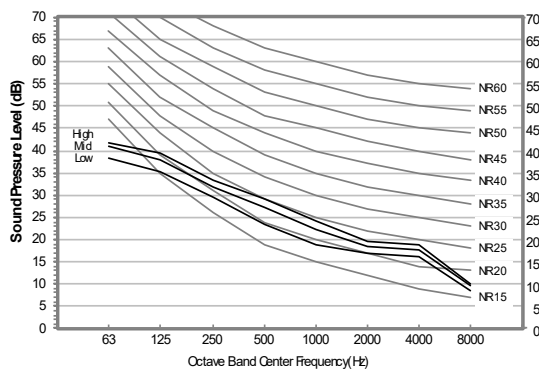

4) AM045DNMFKG/EU

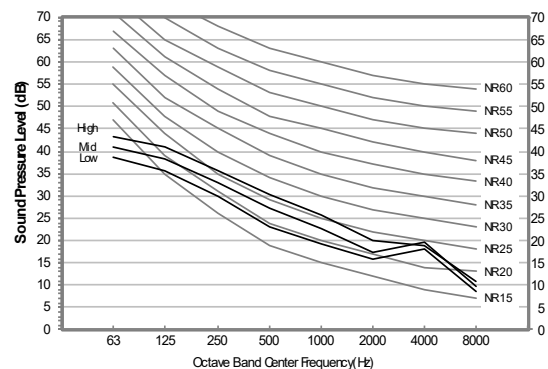

### NOTE

- Specifications may be subject to change without prior notice.
  - Sound pressure level is obtained in an anechoic room.
  - Sound pressure level is a relative value, depending on the distance and acoustic environment.
  - Sound pressure level may differ depending on operation condition.
  - dB(A) = A weighted sound pressure level
  - Reference acoustic pressure 0 dB = 20μPa

# 7. Sound Data

## MSP Duct

### Sound pressure level

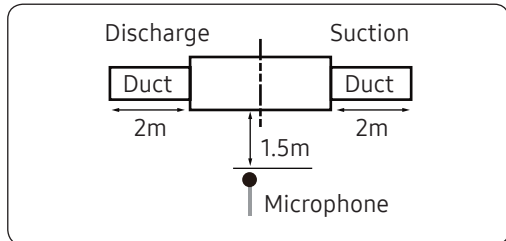

Unit: dB(A)

MODEL	High	Mid	Low
AM056DNMFKG/EU	38	35	31
AM071DNMFKG/EU	39	35	30

- NR Curve

1) AM056DNMFKG/EU

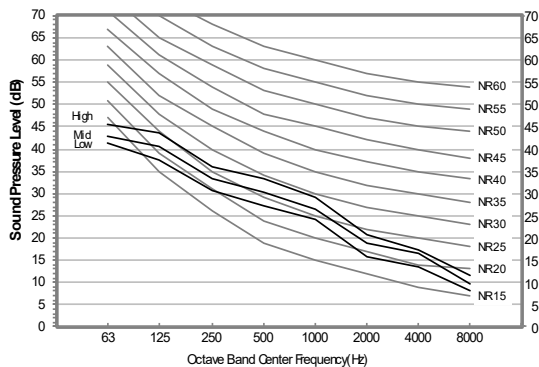

2) AM071DNMFKG/EU

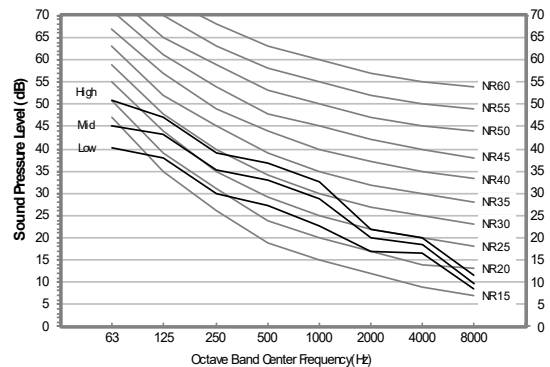

### NOTE

- Specifications may be subject to change without prior notice.
  - Sound pressure level is obtained in an anechoic room.
  - Sound pressure level is a relative value, depending on the distance and acoustic environment.
  - Sound pressure level may differ depending on operation condition.
  - dB(A) = A weighted sound pressure level
  - Reference acoustic pressure 0 dB = 20μPa

# 7. Sound Data

## MSP Duct

### Sound Power level

#### NOTE

- Specifications may be subject to change without prior notice
  - Sound power level is an absolute value that a sound source generates.
  - dBA = A-weighted sound power level.
  - Reference power : 1pW.
  - Measured according to ISO 3741.

Unit: dB(A)

Model	Power
AM022DNMDKG/EU	50
AM028DNMDKG/EU	51
AM036DNMDKG/EU	53
AM045DNMDKG/EU	54

#### • NR Curve

1) AM022DNMDKG/EU

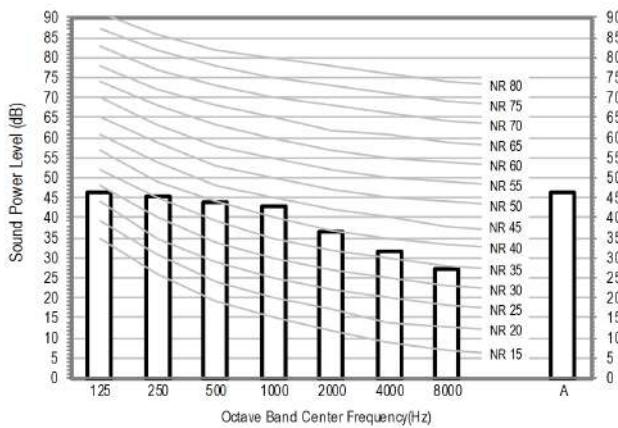

2) AM028DNMDKG/EU

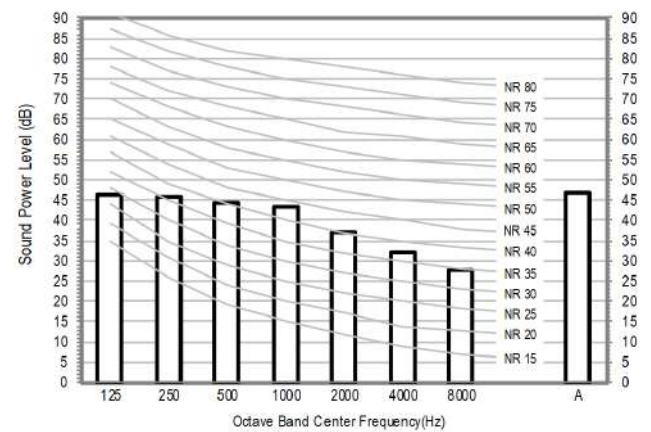

3) AM036DNMDKG/EU

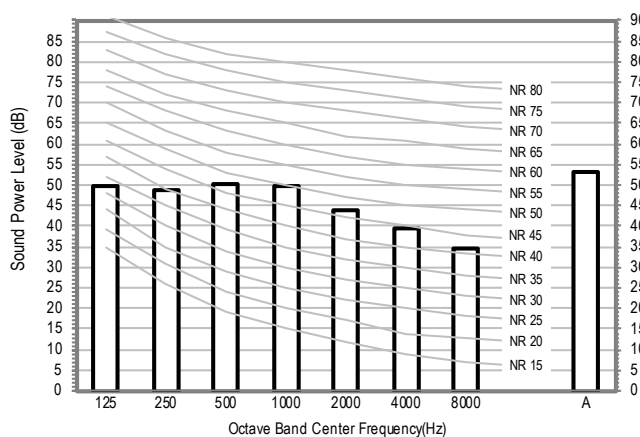

4) AM045DNMDKG/EU

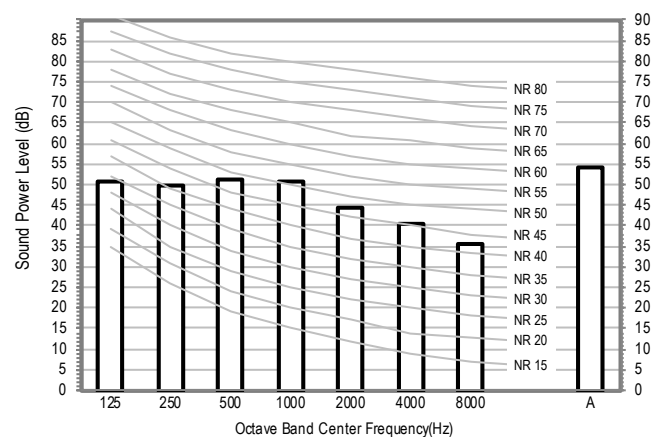

# 7. Sound Data

## MSP Duct

### Sound Power level

#### NOTE

- Specifications may be subject to change without prior notice
  - Sound power level is an absolute value that a sound source generates.
  - dBA = A-weighted sound power level.
  - Reference power : 1pW.
  - Measured according to ISO 3741.

Unit: dB(A)

Model	Power
AM056DNMDKG/EU	57
AM071DNMDKG/EU	60
AM090DNMDKG/EU	61
AM112DNMDKG/EU	61

#### • NR Curve

1) AM056DNMDKG/EU

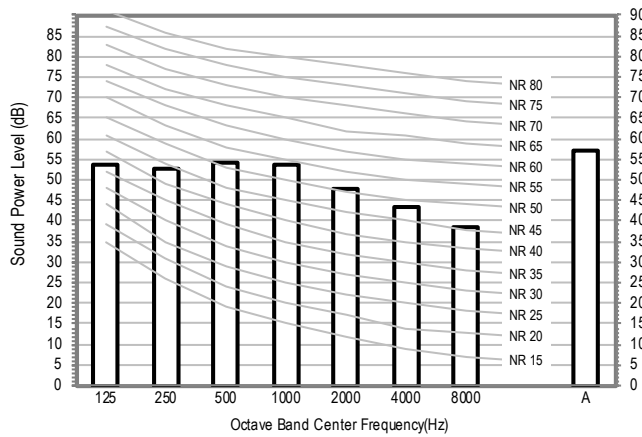

2) AM071DNMDKG/EU

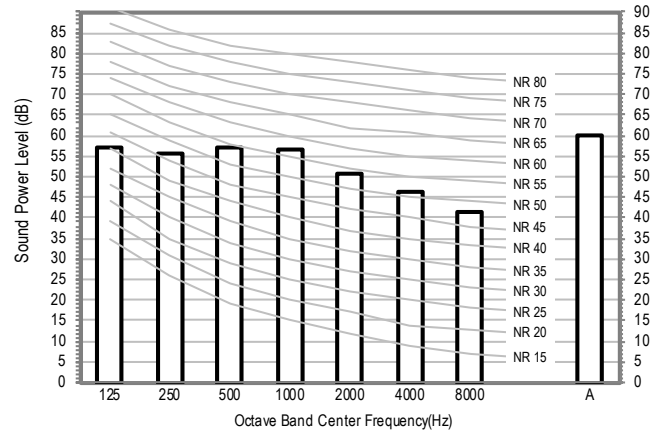

3) AM090DNMDKG/EU

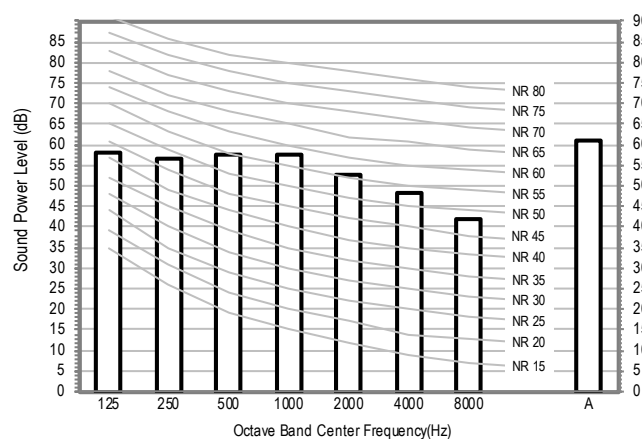

4) AM112DNMDKG/EU

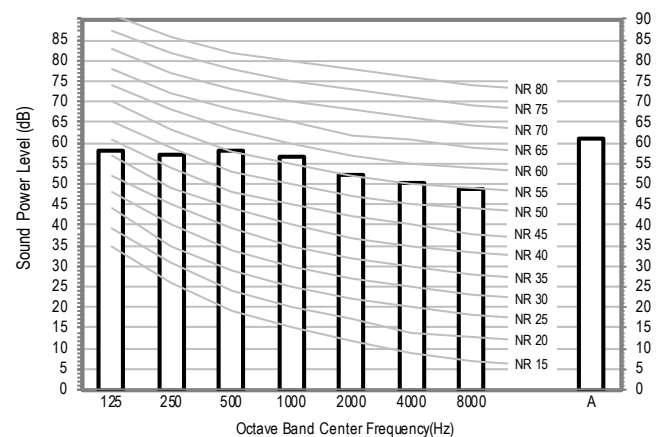

# 7. Sound Data

## MSP Duct

### Sound Power level

#### NOTE

- Specifications may be subject to change without prior notice
  - Sound power level is an absolute value that a sound source generates.
  - dBA = A-weighted sound power level.
  - Reference power : 1pW.
  - Measured according to ISO 3741.

Unit: dB(A)

Model	Power
AM128DNMDKG/EU	62
AM140DNMDKG/EU	64
AM160DNMDKG/EU	65

#### • NR Curve

1) AM128DNMDKG/EU

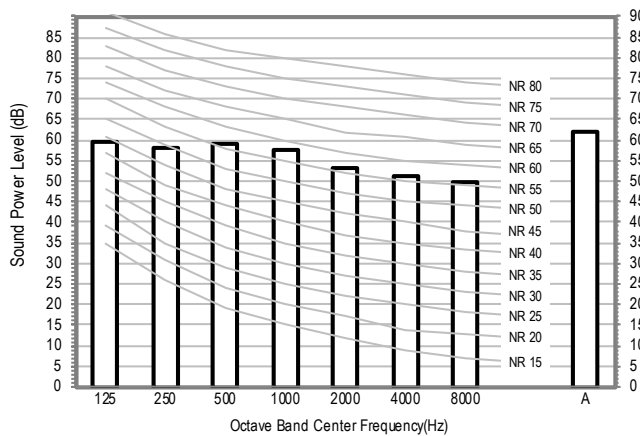

2) AM140DNMDKG/EU

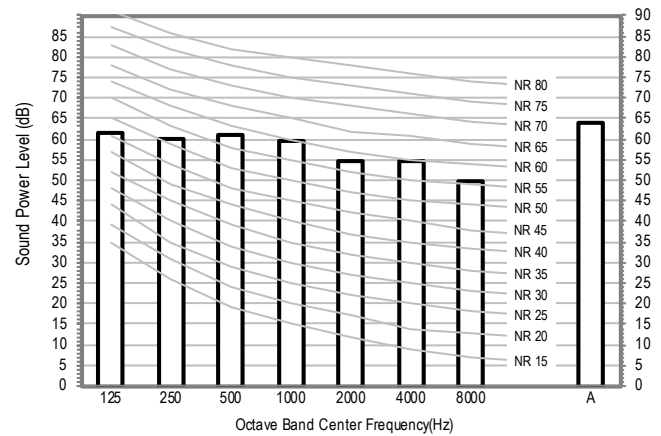

3) AM160DNMDKG/EU

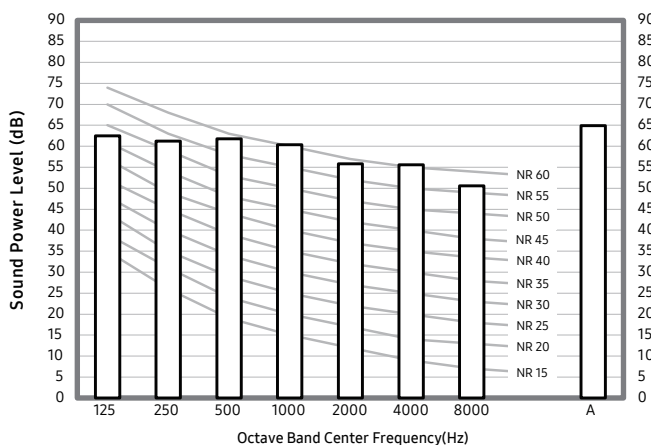

# 7. Sound Data

## MSP Duct

### Sound Power level

#### NOTE

- Specifications may be subject to change without prior notice
  - Sound power level is an absolute value that a sound source generates.
  - dBA = A-weighted sound power level.
  - Reference power : 1pW.
  - Measured according to ISO 3741.

Unit: dB(A)

Model	Power
AM022DNMFKG/EU	55
AM028DNMFKG/EU	56
AM036DNMFKG/EU	57
AM045DNMFKG/EU	57

#### NR Curve

1) AM022DNMFKG/EU

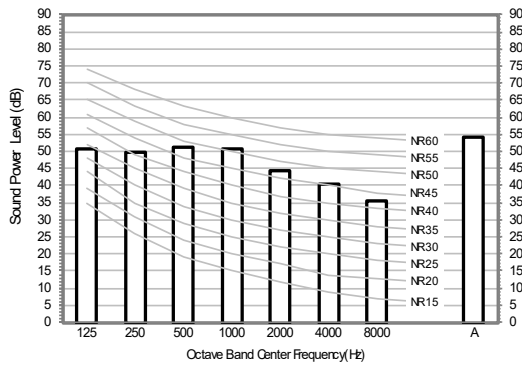

2) AM028DNMFKG/EU

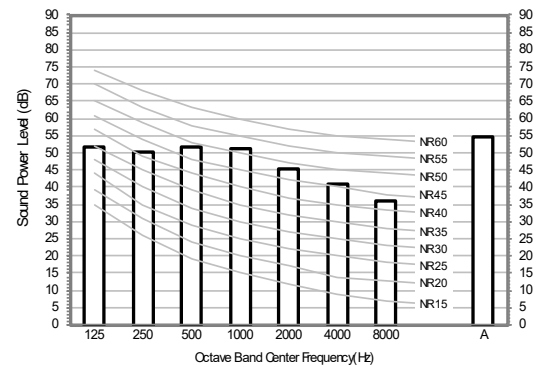

3) AM036DNMFKG/EU

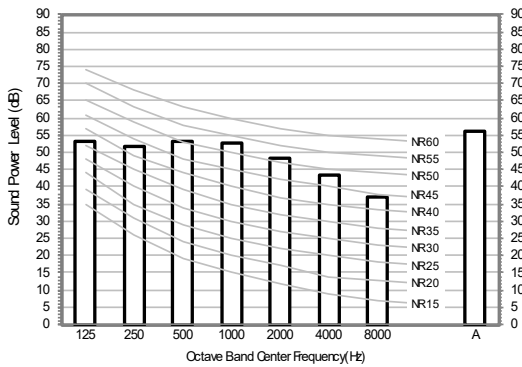

4) AM045DNMFKG/EU

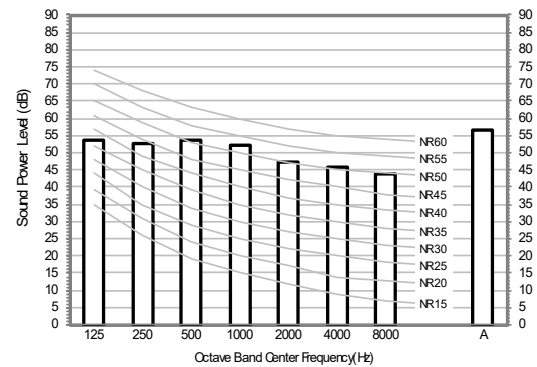

# 7. Sound Data

## MSP Duct

### Sound Power level

#### NOTE

- Specifications may be subject to change without prior notice
  - Sound power level is an absolute value that a sound source generates.
  - dBA = A-weighted sound power level.
  - Reference power : 1pW.
  - Measured according to ISO 3741.

Unit: dB(A)

Model	Power
AM056DNMFKG/EU	63
AM071DNMFKG/EU	63

- NR Curve

1) AM056DNMFKG/EU

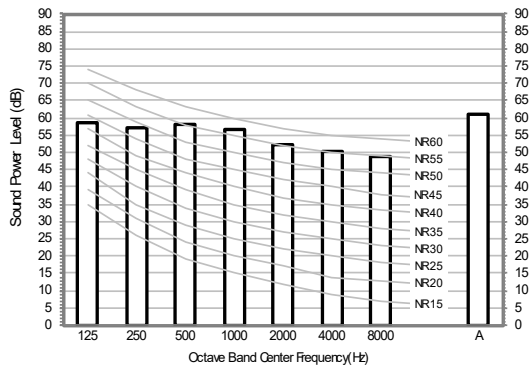

2) AM071DNMFKG/EU

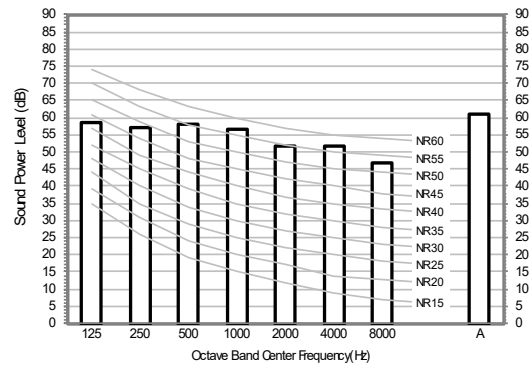

# 8. Fan Characteristics

## MSP Duct

### AM022DNMDKG/EU

①	External Static Pressure(mmAq)	Option Code
	$0 \leq SP \leq 2.5$ (Std.)	010054-1E50A2-201616-331100

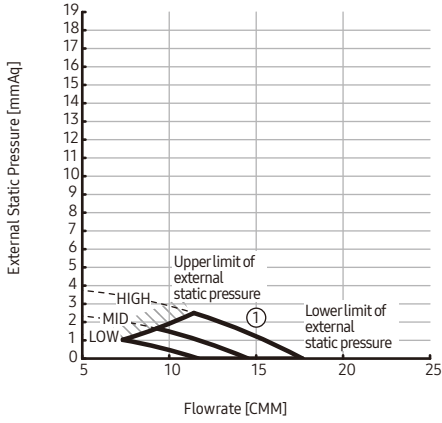

②	External Static Pressure(mmAq)	Option Code
	$2.5 < SP \leq 5$	010054-1E5417-201616-331100

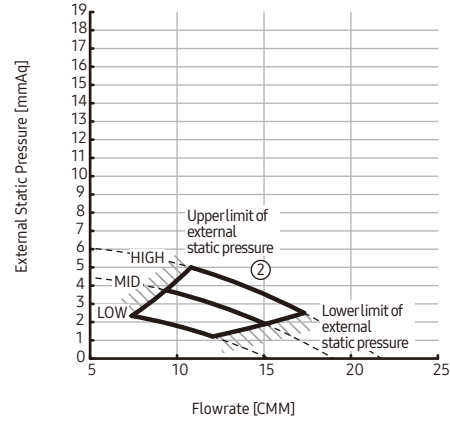

③	External Static Pressure(mmAq)	Option Code
	$5 < SP \leq 7.5$	010054-1E5489-201616-331100

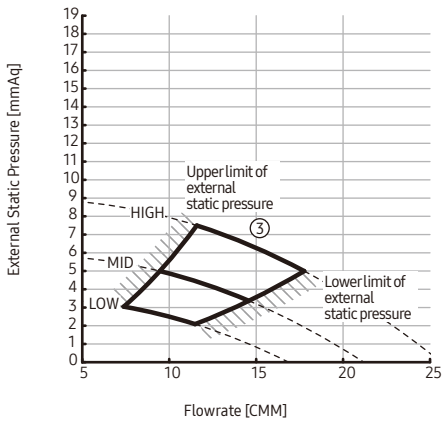

④	External Static Pressure(mmAq)	Option Code
	$7.5 < SP \leq 10$	010054-1E54DE-201616-331100

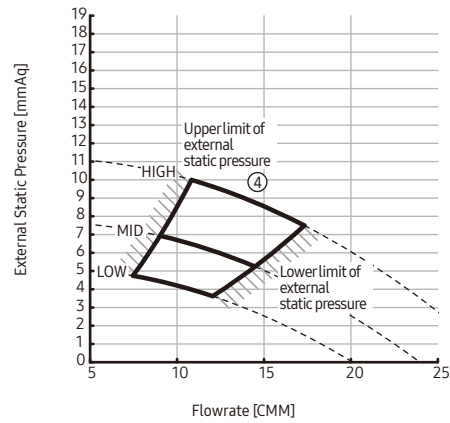

⑤	External Static Pressure(mmAq)	Option Code
	$10 < SP \leq 12.5$	010054-1E5921-201616-331100

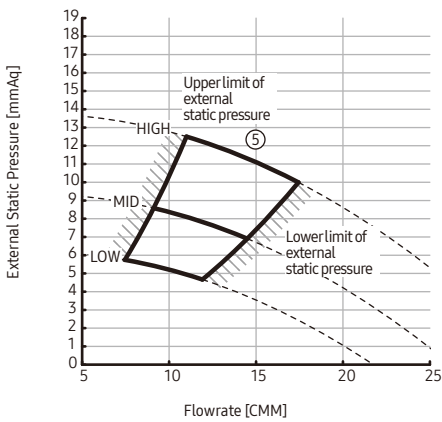

⑥	External Static Pressure(mmAq)	Option Code
	$12.5 < SP \leq 15$	010054-1E5971-201616-331100

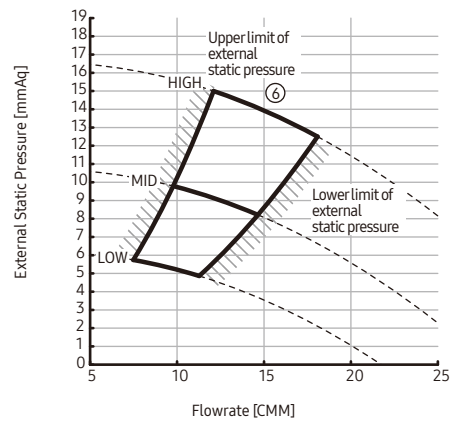

# 8. Fan Characteristics

## MSP Duct

### AM028DNMDKG/EU

①	External Static Pressure(mmAq)	Option Code
	0<SP≤2.5 (Std.)	010054-1E50A2-201C1C-331100

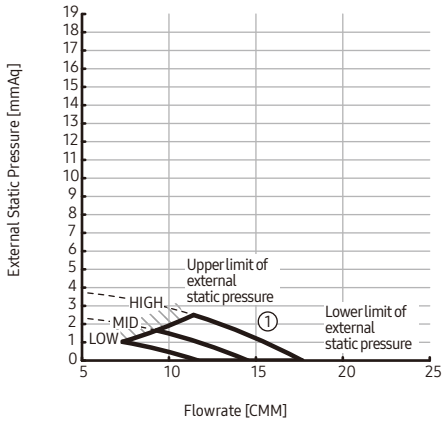

②	External Static Pressure(mmAq)	Option Code
	2.5<SP≤5	010054-1E5417-201C1C-331100

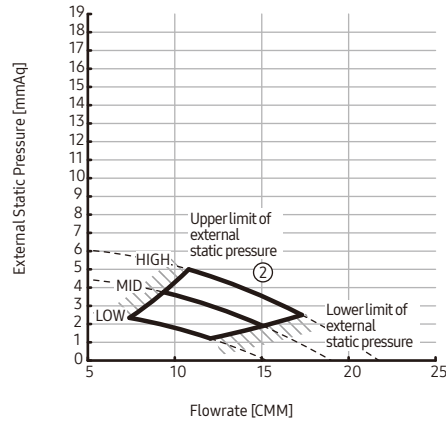

③	External Static Pressure(mmAq)	Option Code
	5<SP≤7.5	010054-1E5489-201C1C-331100

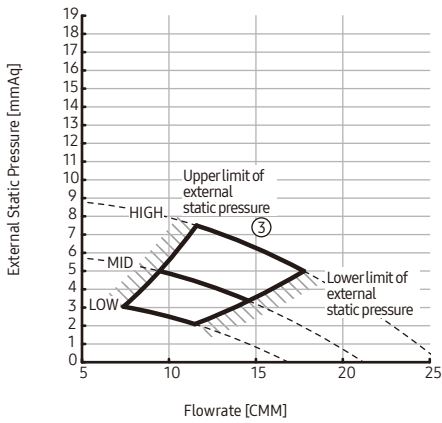

④	External Static Pressure(mmAq)	Option Code
	7.5<SP≤10	010054-1E54DE-201C1C-331100

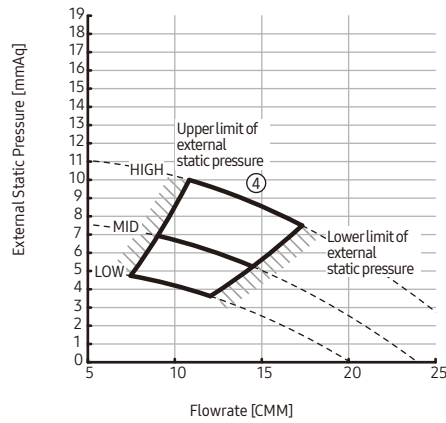

⑤	External Static Pressure(mmAq)	Option Code
	10<SP≤12.5	010054-1E5921-201C1C-331100

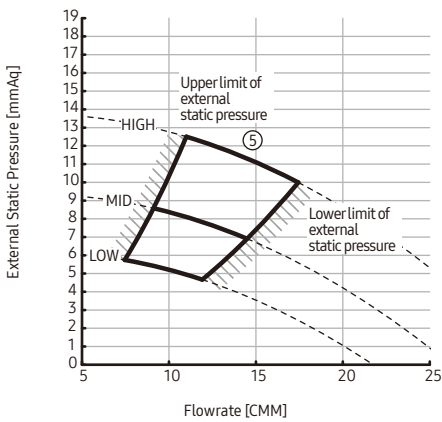

⑥	External Static Pressure(mmAq)	Option Code
	12.5<SP≤15	010054-1E5971-201C1C-331100

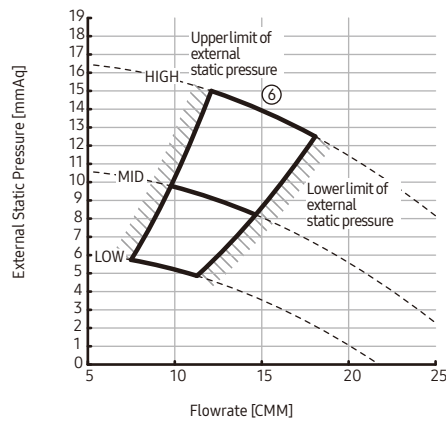

# 8. Fan Characteristics

## MSP Duct

### AM036DNMDKG/EU

①	External Static Pressure(mmAq)	Option Code
	0<SP≤2.5	010054-1E50B2-202424-331100

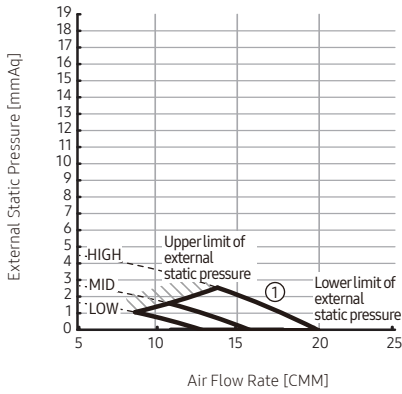

②	External Static Pressure(mmAq)	Option Code
	2.5<SP≤5	010054-1E5436-202424-331100

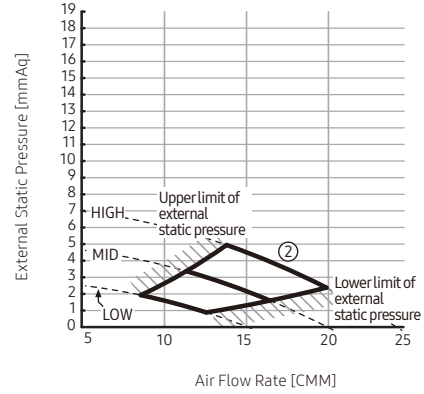

③	External Static Pressure(mmAq)	Option Code
	5<SP≤7.5	010054-1E5499-202424-331100

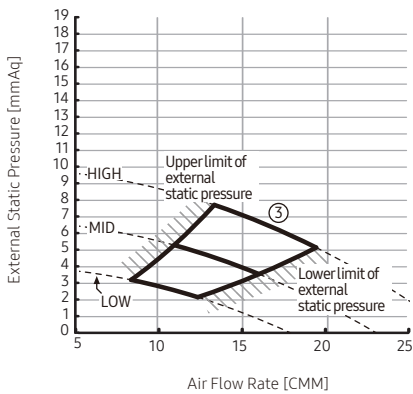

④	External Static Pressure(mmAq)	Option Code
	7.5<SP≤10	010054-1E54EB-202424-331100

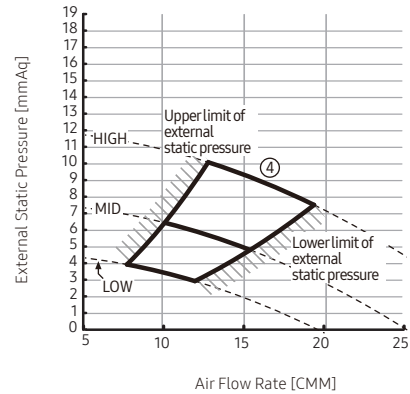

⑤	External Static Pressure(mmAq)	Option Code
	10<SP≤12.5	010054-1E583E-202424-331100

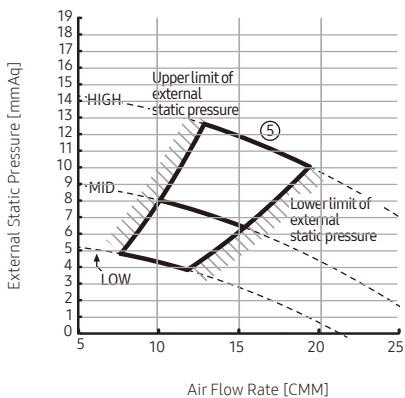

⑥	External Static Pressure(mmAq)	Option Code
	12.5<SP≤15	010054-1E5972-202424-331100

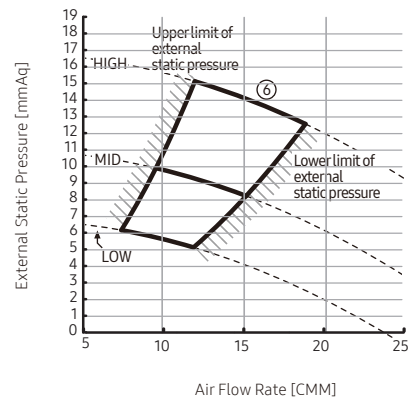

# 8. Fan Characteristics

## MSP Duct

### AM045DNMDKG/EU

①	External Static Pressure(mmAq)	Option Code
	0<SP≤3	010054-1E50E3-202D2D-331100

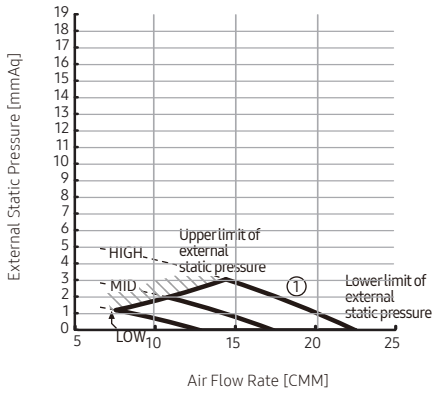

②	External Static Pressure(mmAq)	Option Code
	3<SP≤6	010054-1E5467-202D2D-331100

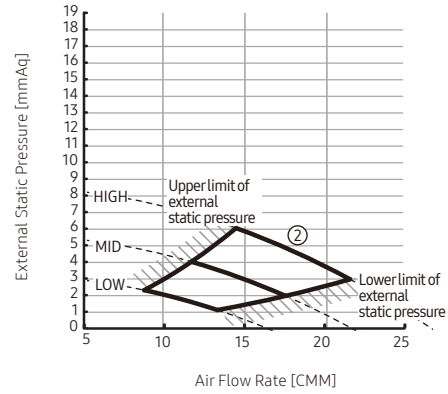

③	External Static Pressure(mmAq)	Option Code
	6<SP≤9	010054-1E54DA-202D2D-331100

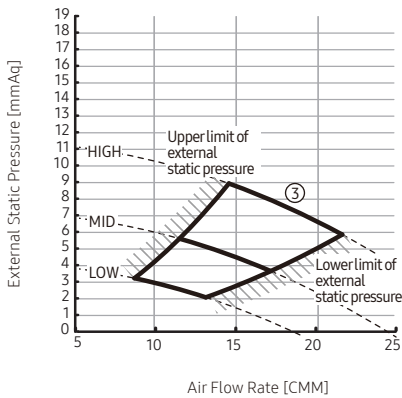

④	External Static Pressure(mmAq)	Option Code
	9<SP≤12	010054-1E582D-202D2D-331100

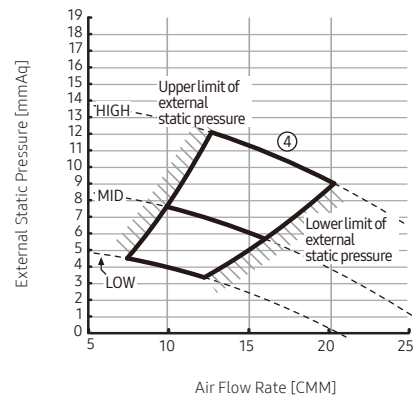

⑤	External Static Pressure(mmAq)	Option Code
	12<SP≤15	010054-1E5981-202D2D-331100

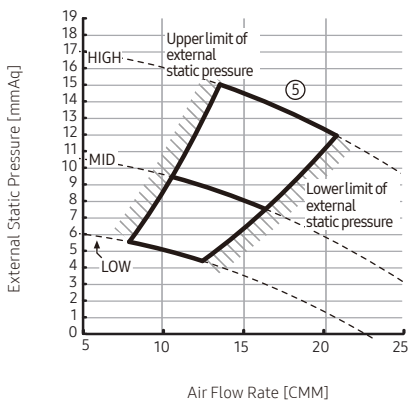

# 8. Fan Characteristics

## MSP Duct

### AM056DNMDKG/EU

①	External Static Pressure(mmAq)	Option Code
	0<SP≤3	010054-1E5413-203838-331100

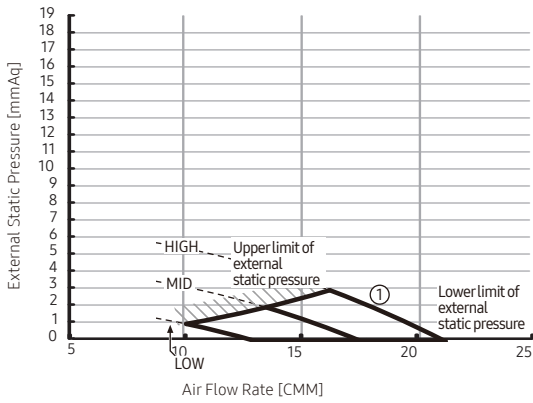

②	External Static Pressure(mmAq)	Option Code
	3<SP≤6	010054-1E5497-203838-331100

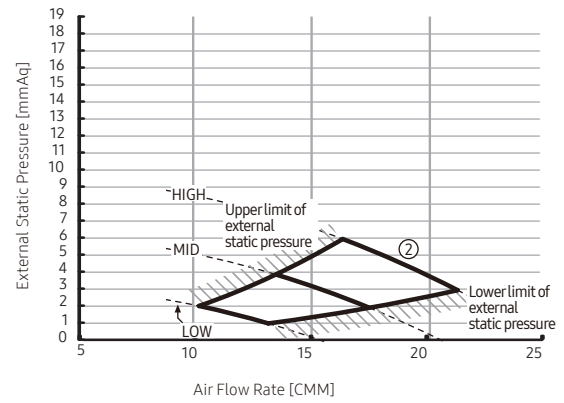

③	External Static Pressure(mmAq)	Option Code
	6<SP≤9	010054-1E54FA-203838-331100

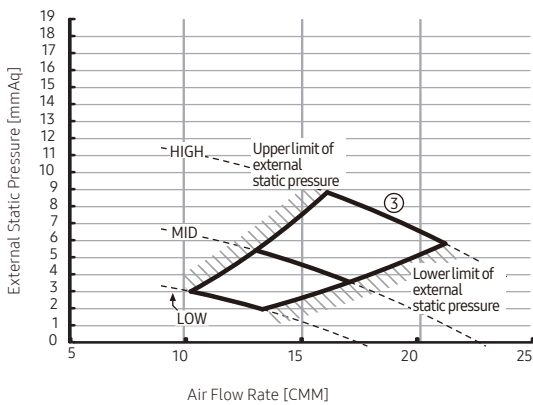

④	External Static Pressure(mmAq)	Option Code
	9<SP≤12	010054-1E585C-203838-331100

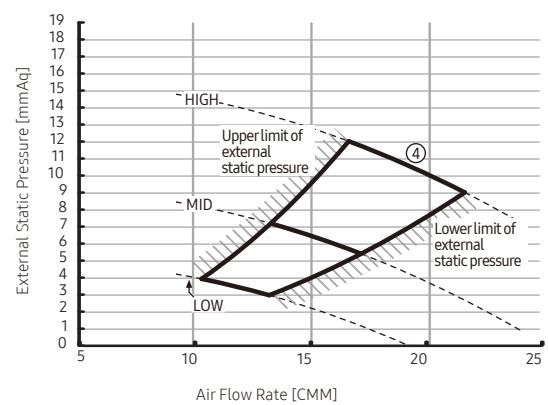

⑤	External Static Pressure(mmAq)	Option Code
	12<SP≤15	010054-1E58AE-203838-331100

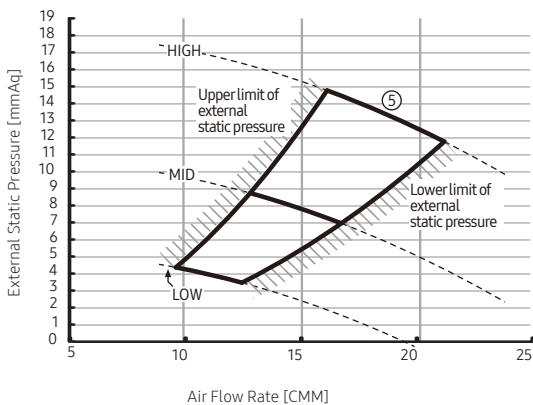

# 8. Fan Characteristics

## MSP Duct

### AM071DNMDKG/EU

①	External Static Pressure(mmAq)	Option Code
	0≤SP≤3	010054-1E5488-204747-331100

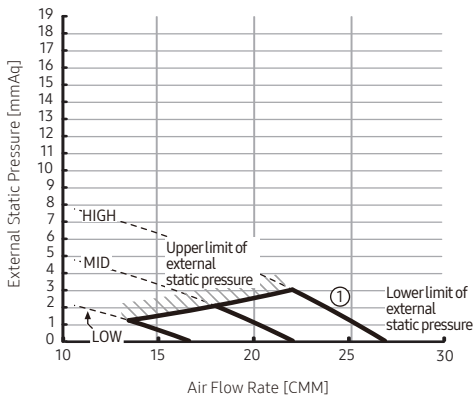

②	External Static Pressure(mmAq)	Option Code
	3<SP≤6	010054-1E54FB-204747-331100

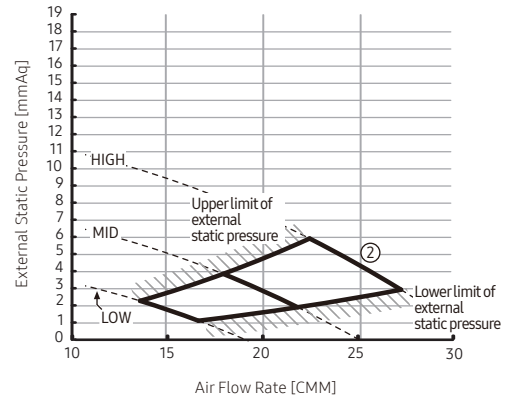

③	External Static Pressure(mmAq)	Option Code
	6<SP≤9	010054-1E584F-204747-331100

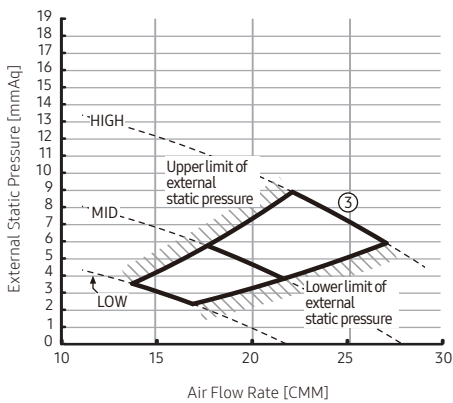

④	External Static Pressure(mmAq)	Option Code
	9<SP≤12	010054-1E59A2-204747-331100

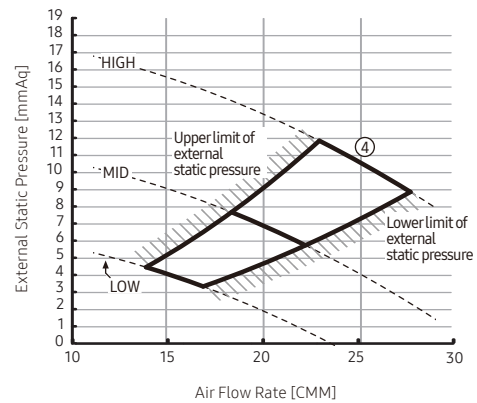

⑤	External Static Pressure(mmAq)	Option Code
	12<SP≤15	010054-1E59E5-204747-331100

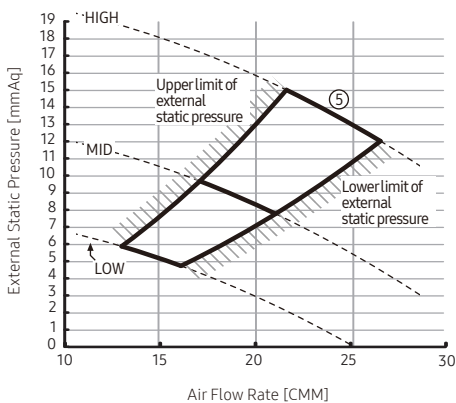

# 8. Fan Characteristics

## MSP Duct

### AM090DNMDKG/EU

①	External Static Pressure(mmAq)	Option Code
	0≤SP≤4	010054-1E5477-205A5A-331110

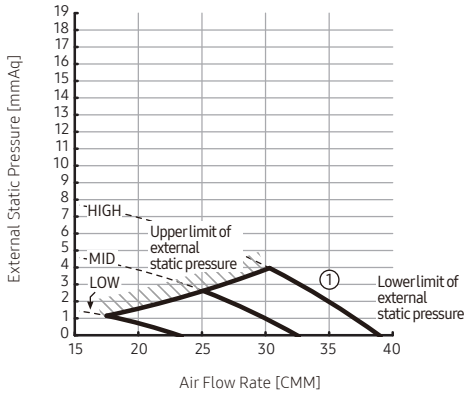

②	External Static Pressure(mmAq)	Option Code
	4<SP≤8	010054-1E580A-205A5A-331110

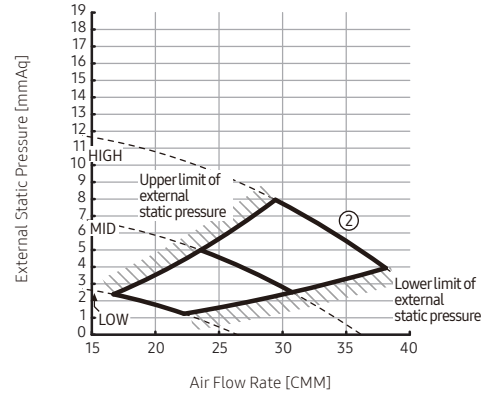

③	External Static Pressure(mmAq)	Option Code
	8<SP≤12	010054-1E588D-205A5A-331110

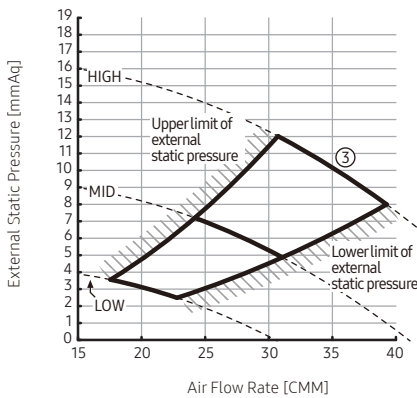

④	External Static Pressure(mmAq)	Option Code
	12<SP≤15	010054-1E59C2-205A5A-331110

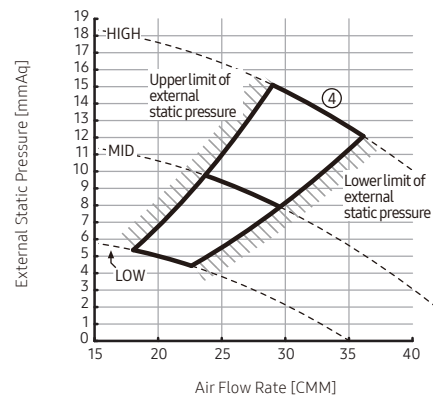

# 8. Fan Characteristics

## MSP Duct

### AM112DNMDKG/EU

①	External Static Pressure(mmAq)	Option Code
	0<SP≤5.2	010054-1E5405-207070-331120

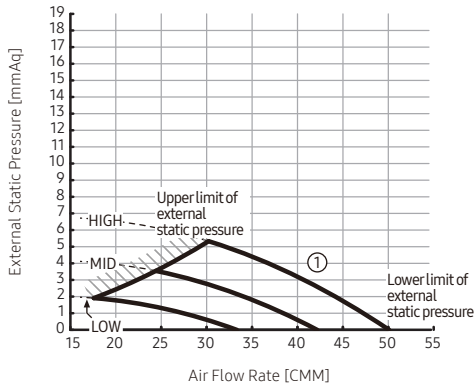

②	External Static Pressure(mmAq)	Option Code
	5.2<SP≤8	010054-1E5469-207070-331120

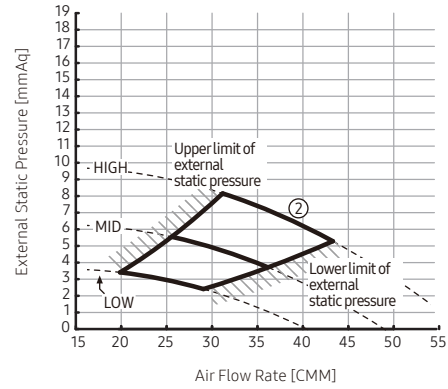

③	External Static Pressure(mmAq)	Option Code
	8<SP≤12	010054-1E54DA-207070-331120

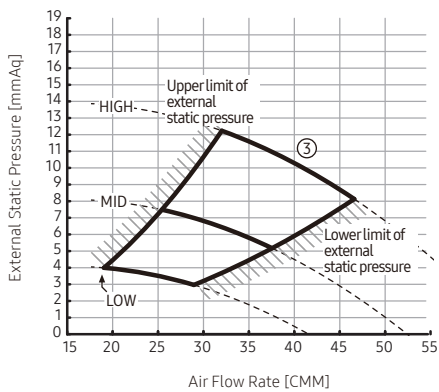

④	External Static Pressure(mmAq)	Option Code
	12<SP≤14	010054-1E580D-207070-331120

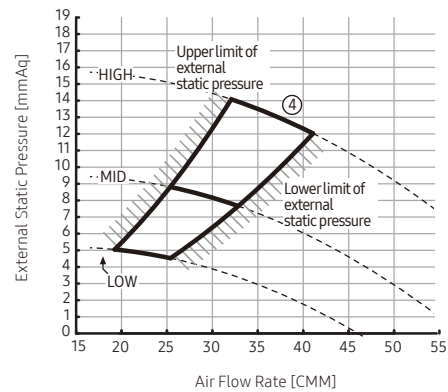

⑤	External Static Pressure(mmAq)	Option Code
	14<SP≤15	010054-1E582D-207070-331120

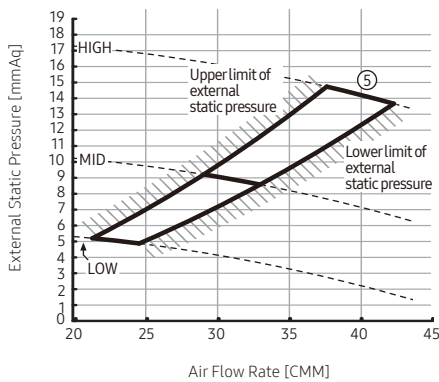

# 8. Fan Characteristics

## MSP Duct

### AM128DNMDKG/EU

①	External Static Pressure(mmAq)	Option Code
	0<SP≤5.2	010054-1E5437-208080-331120

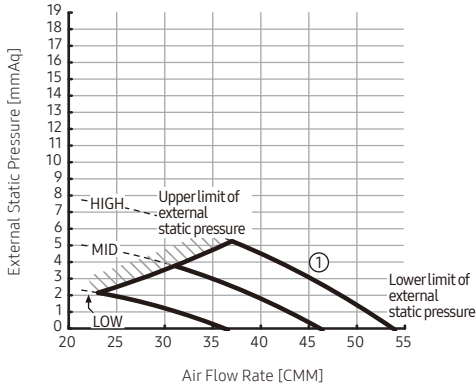

②	External Static Pressure(mmAq)	Option Code
	5.2<SP≤8	010054-1E5489-208080-331120

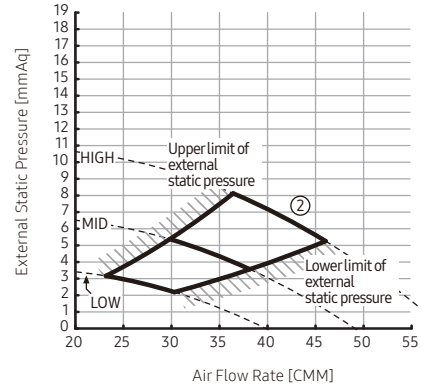

③	External Static Pressure(mmAq)	Option Code
	8<SP≤12	010054-1E54FD-208080-331120

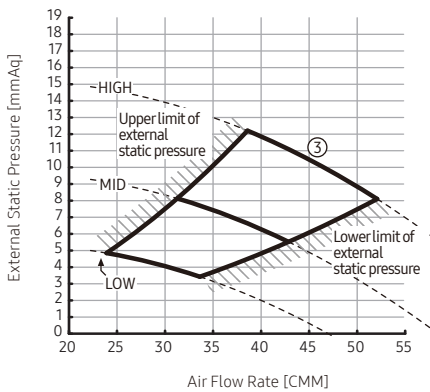

④	External Static Pressure(mmAq)	Option Code
	12<SP≤14	010054-1E581F-208080-331120

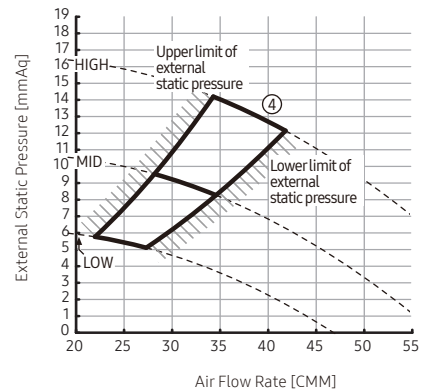

⑤	External Static Pressure(mmAq)	Option Code
	14<SP≤15	010054-1E583F-208080-331120

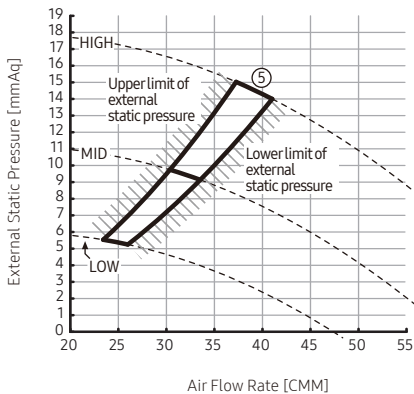

# 8. Fan Characteristics

## MSP Duct

### AM140DNMDKG/EU

①	External Static Pressure(mmAq)	Option Code
	0≤SP≤5.2	010054-1E5467-208C8C-331120

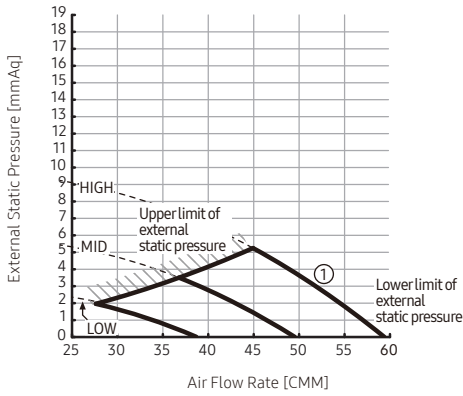

②	External Static Pressure(mmAq)	Option Code
	5.2<SP≤8	010054-1E54B9-208C8C-331120

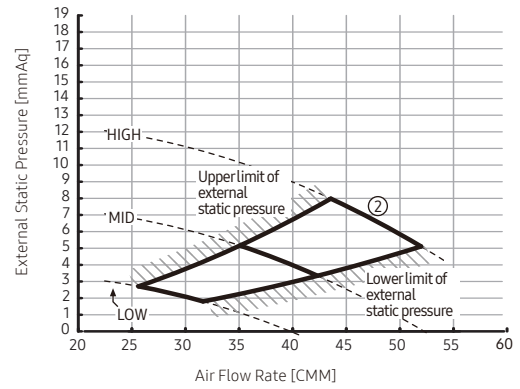

③	External Static Pressure(mmAq)	Option Code
	8<SP≤12	010054-1E581D-208C8C-331120

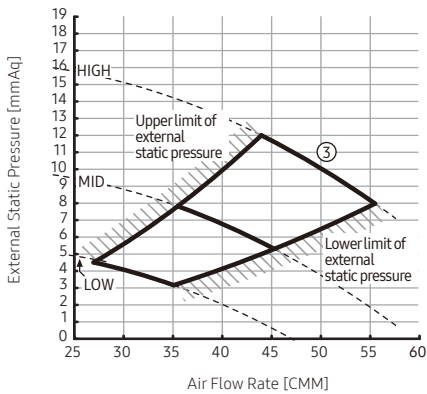

④	External Static Pressure(mmAq)	Option Code
	12<SP≤14	010054-1E582F-208C8C-331120

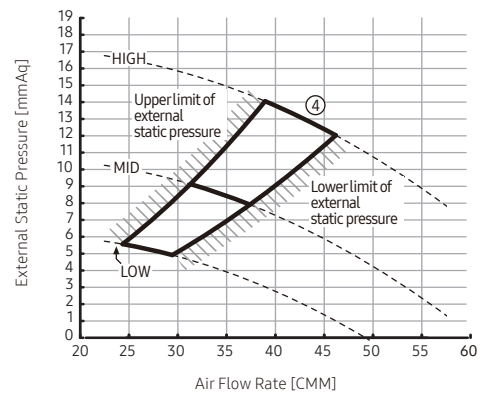

⑤	External Static Pressure(mmAq)	Option Code
	14<SP≤15	010054-1E5940-208C8C-331120

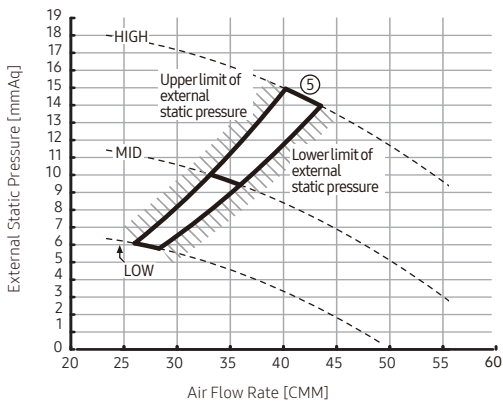

# 8. Fan Characteristics

## MSP Duct

### AM160DNMDKG/EU

①	External Static Pressure(mmAq)	Option Code
	$0 \leq SP \leq 5.2$	010054-1E54B9-20A0A0-331120

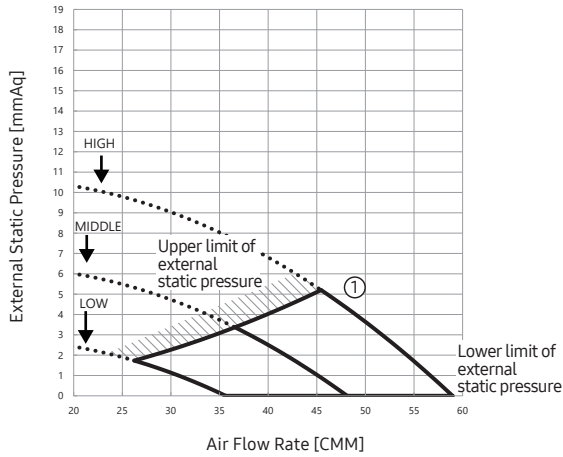

②	External Static Pressure(mmAq)	Option Code
	$5.2 < SP \leq 8$	010054-1E580A-20A0A0-331120

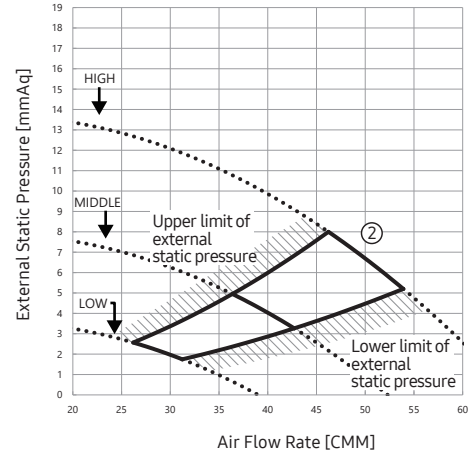

③	External Static Pressure(mmAq)	Option Code
	$8 < SP \leq 12$	010054-1E583C-20A0A0-331120

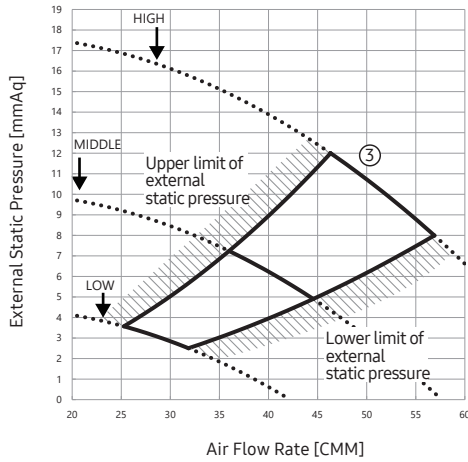

④	External Static Pressure(mmAq)	Option Code
	$12 < SP \leq 14$	010054-1E586D-20A0A0-331120

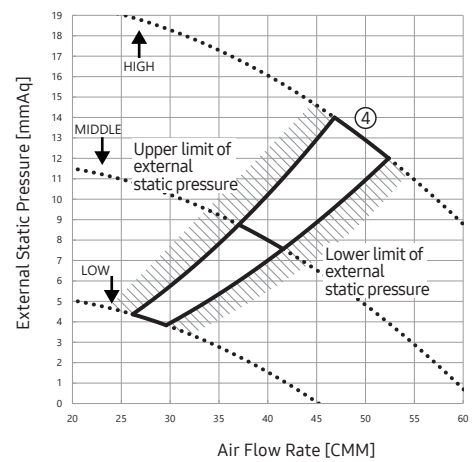

⑤	External Static Pressure(mmAq)	Option Code
	$14 < SP \leq 15$	010054-1E589E-20A0A0-331120

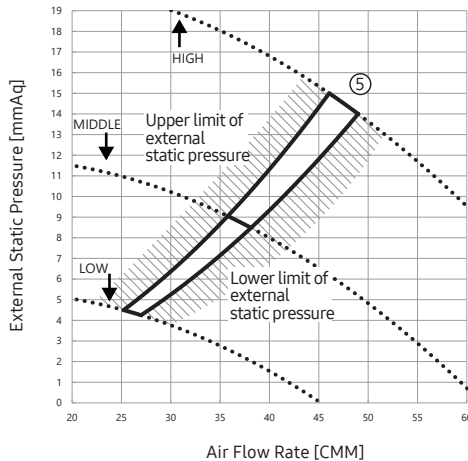

# 8. Fan Characteristics

## MSP Duct

### AM022DNMFKG/EU

①	External Static Pressure(mmAq)	Option Code
	0<SP≤3	010054-1E5086-201616-331110

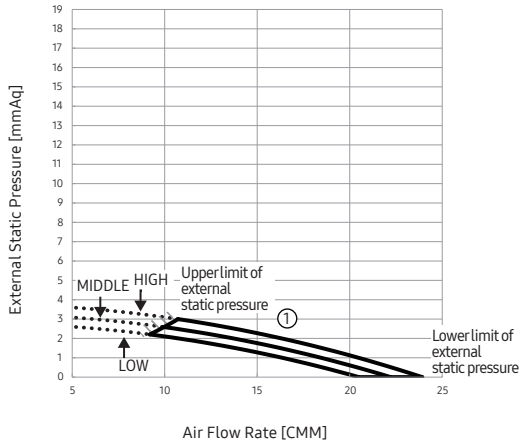

②	External Static Pressure(mmAq)	Option Code
	3<SP≤6	010054-1E540C-201616-331110

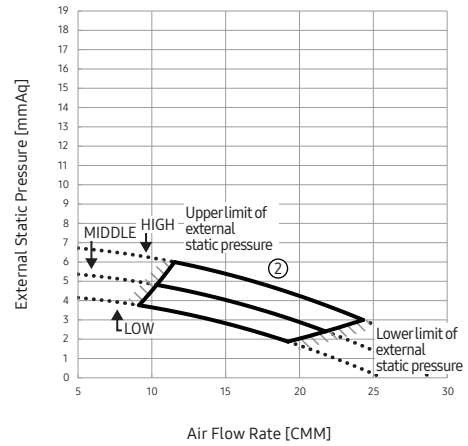

③	External Static Pressure(mmAq)	Option Code
	6<SP≤9	010054-1E5584-201616-331110

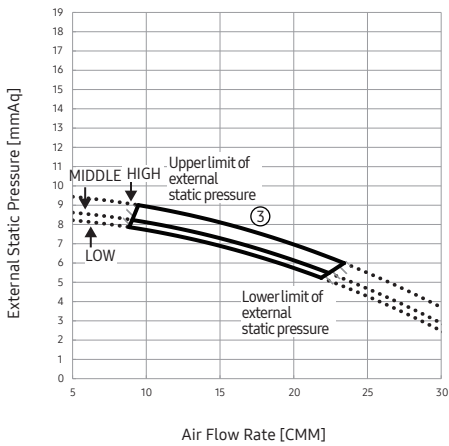

④	External Static Pressure(mmAq)	Option Code
	9<SP≤12	010054-1E55F9-201616-331110

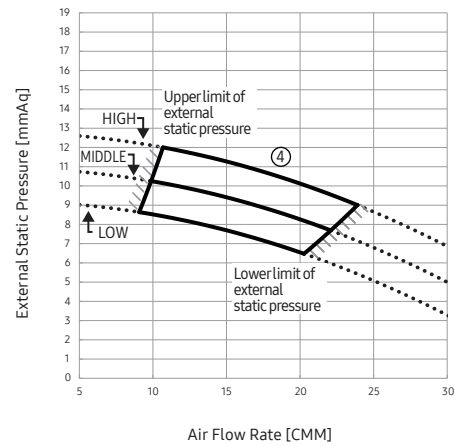

⑤	External Static Pressure(mmAq)	Option Code
	12<SP≤15	010054-1E5A51-201616-331110

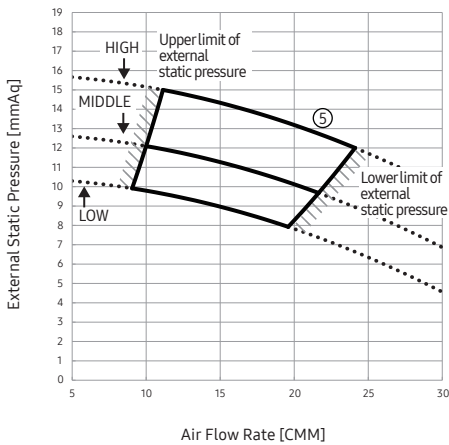

# 8. Fan Characteristics

## MSP Duct

### AM028DNMFKG/EU

①	External Static Pressure(mmAq)	Option Code
	0<SP≤3	010054-1E5096-201C1C-331110

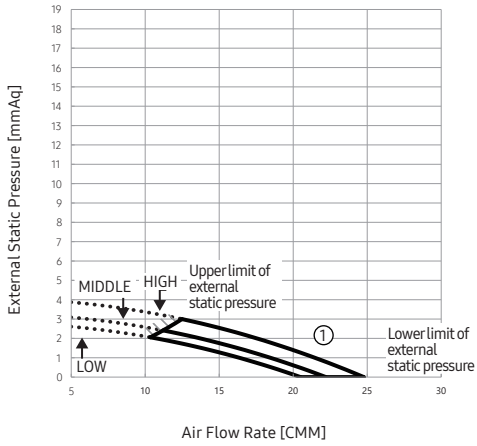

②	External Static Pressure(mmAq)	Option Code
	3<SP≤6	010054-1E541D-201C1C-331110

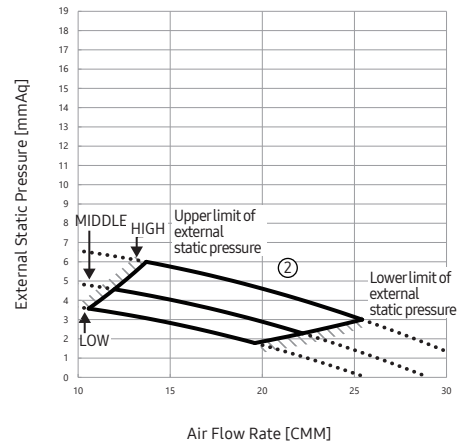

③	External Static Pressure(mmAq)	Option Code
	6<SP≤9	010054-1E5592-201C1C-331110

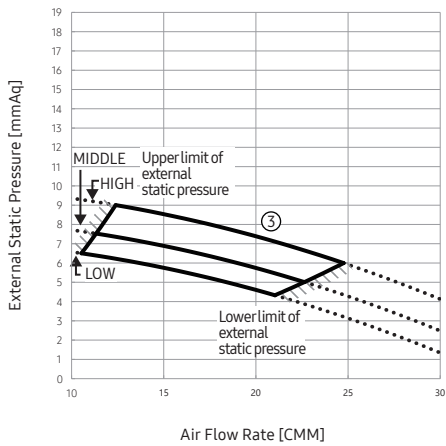

④	External Static Pressure(mmAq)	Option Code
	9<SP≤12	010054-1E5905-201C1C-331110

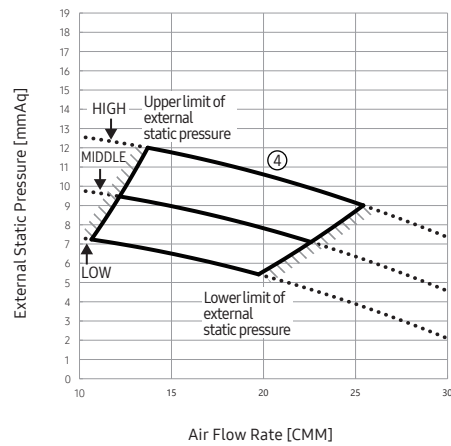

⑤	External Static Pressure(mmAq)	Option Code
	12<SP≤15	010054-1E596A-201C1C-331110

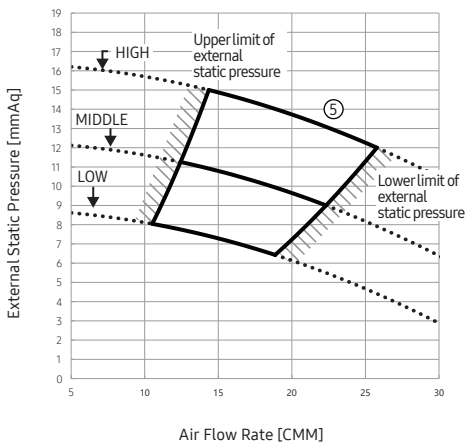

# 8. Fan Characteristics

## MSP Duct

### AM036DNMFKG/EU

①	External Static Pressure(mmAq)	Option Code
	0<SP≤3	010054-1E50A6-202424-331110

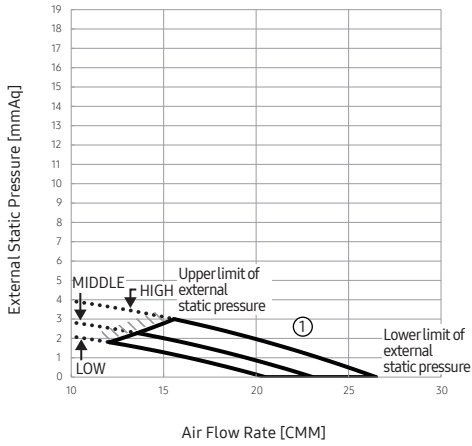

②	External Static Pressure(mmAq)	Option Code
	3<SP≤6	010054-1E543A-202424-331110

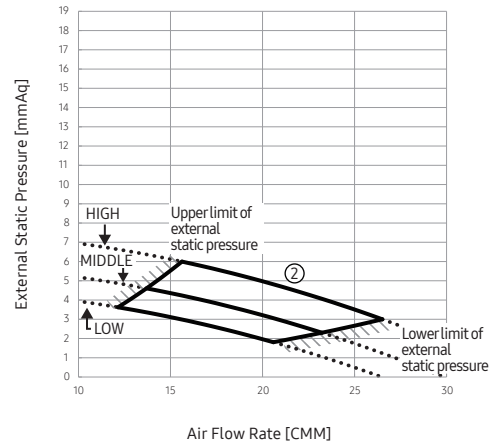

③	External Static Pressure(mmAq)	Option Code
	6<SP≤9	010054-1E55A2-202424-331110

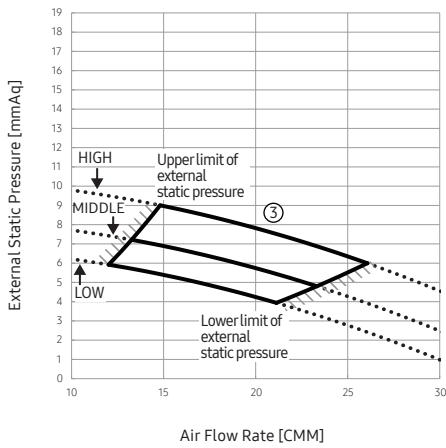

④	External Static Pressure(mmAq)	Option Code
	9<SP≤12	010054-1E5915-202424-331110

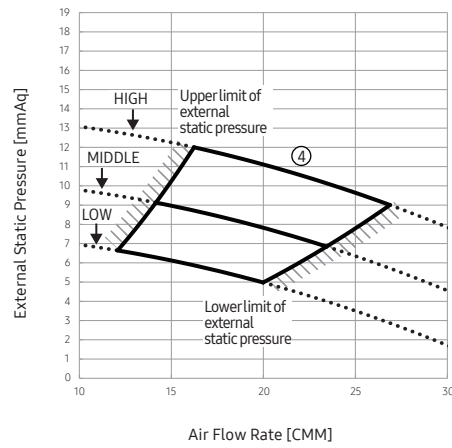

⑤	External Static Pressure(mmAq)	Option Code
	12<SP≤15	010054-1E597A-202424-331110

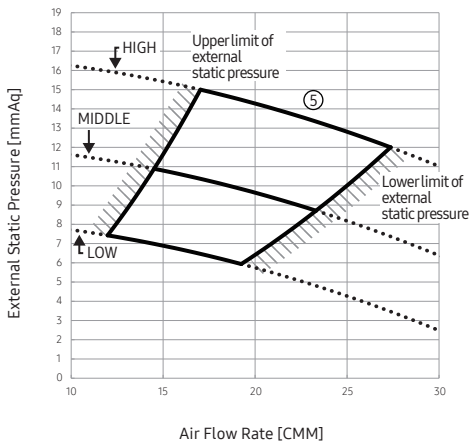

# 8. Fan Characteristics

## MSP Duct

### AM045DNMFKG/EU

①	External Static Pressure(mmAq)	Option Code
	0<SP≤3	010054-1E50C6-202D2D-331110

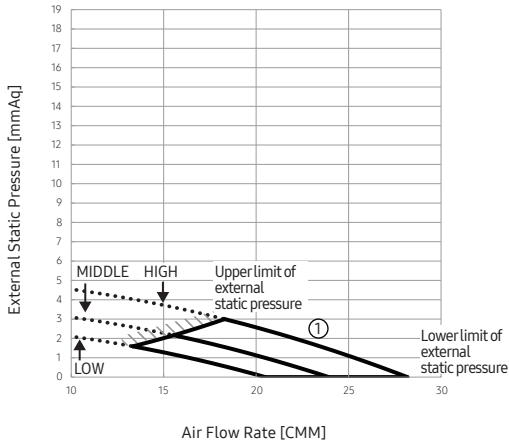

②	External Static Pressure(mmAq)	Option Code
	3<SP≤6	010054-1E545A-202D2D-331110

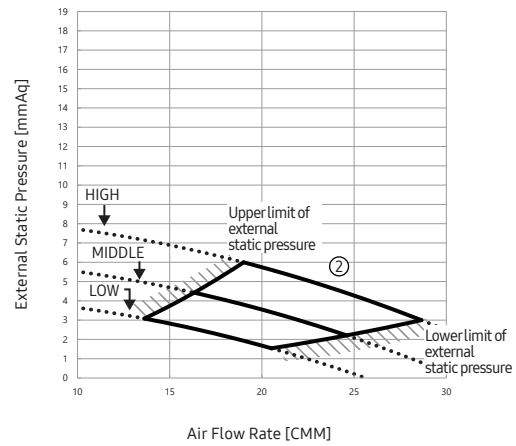

③	External Static Pressure(mmAq)	Option Code
	6<SP≤9	010054-1E55C0-202D2D-331110

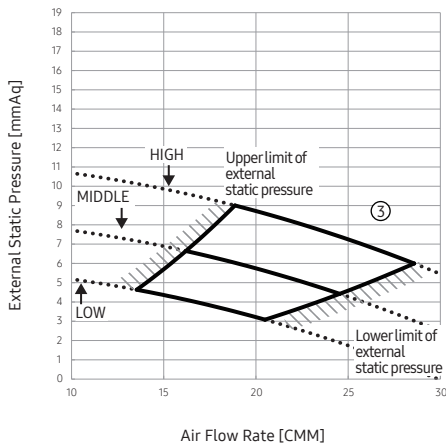

④	External Static Pressure(mmAq)	Option Code
	9<SP≤12	010054-1E5930-202D2D-331110

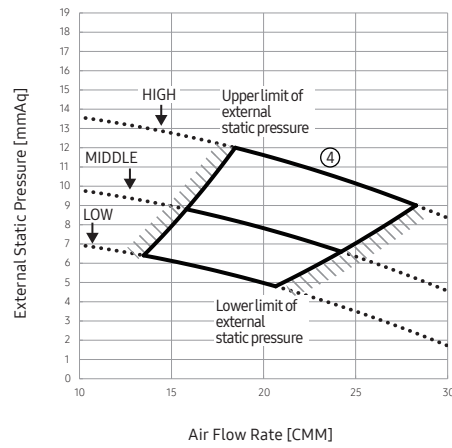

⑤	External Static Pressure(mmAq)	Option Code
	12<SP≤15	010054-1E598C-202D2D-331110

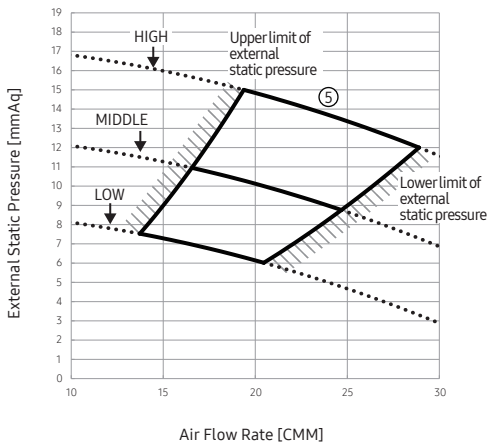

# 8. Fan Characteristics

## MSP Duct

### AM056DNMFKG/EU

①	External Static Pressure(mmAq)	Option Code
	0<SP≤5.2	010054-1E50D7-203838-331120

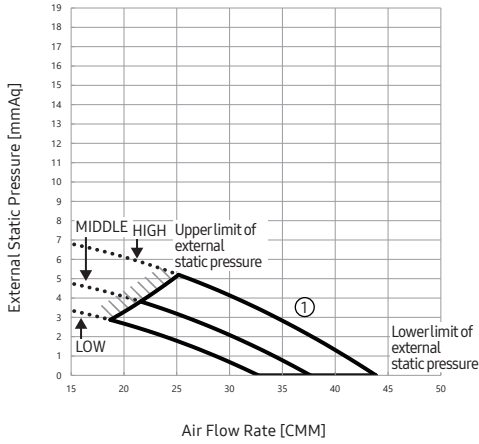

②	External Static Pressure(mmAq)	Option Code
	5.2<SP≤8	010054-1E543A-203838-331120

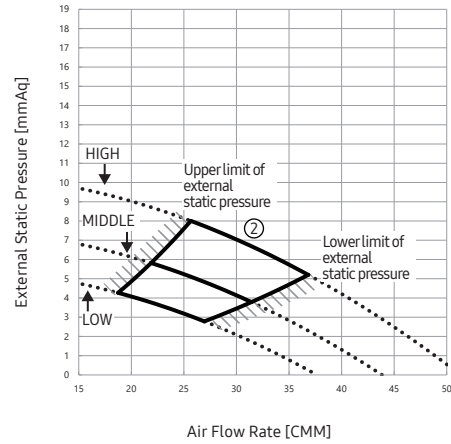

③	External Static Pressure(mmAq)	Option Code
	8<SP≤12	010054-1E54BF-203838-331120

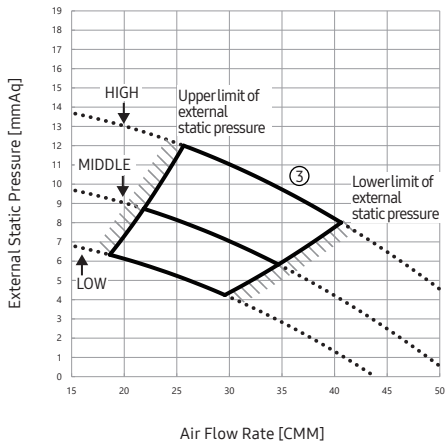

④	External Static Pressure(mmAq)	Option Code
	12<SP≤14	010054-1E54FF-203838-331120

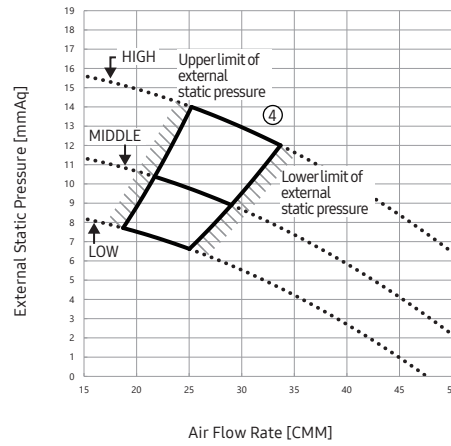

⑤	External Static Pressure(mmAq)	Option Code
	14<SP≤15	010054-1E5906-203838-331120

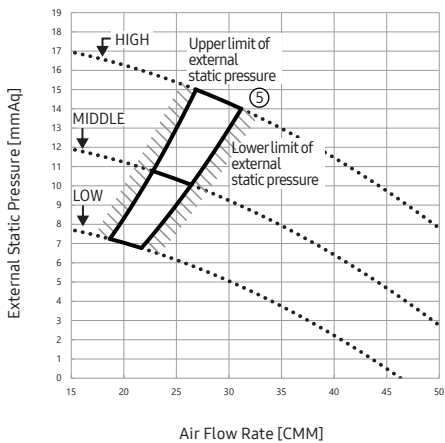

# 8. Fan Characteristics

## MSP Duct

### AM071DNMFKG/EU

①	External Static Pressure(mmAq)	Option Code
	0<SP≤5.2	010054-1E5419-204747-331120

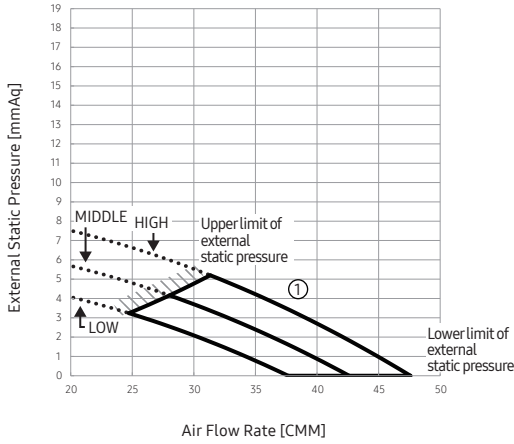

②	External Static Pressure(mmAq)	Option Code
	5.2<SP≤8	010054-1E547B-204747-331120

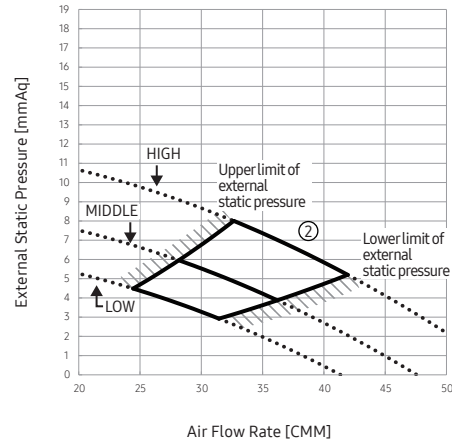

③	External Static Pressure(mmAq)	Option Code
	8<SP≤12	010054-1E59E1-204747-331120

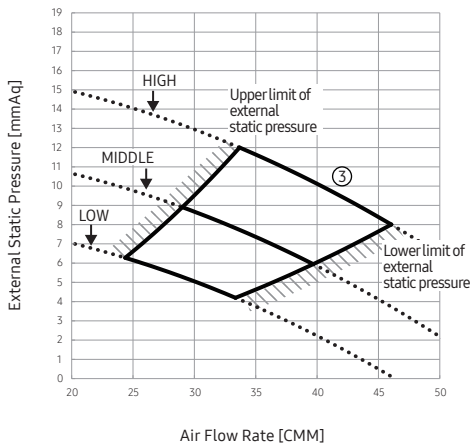

④	External Static Pressure(mmAq)	Option Code
	12<SP≤14	010054-1E5914-204747-331120

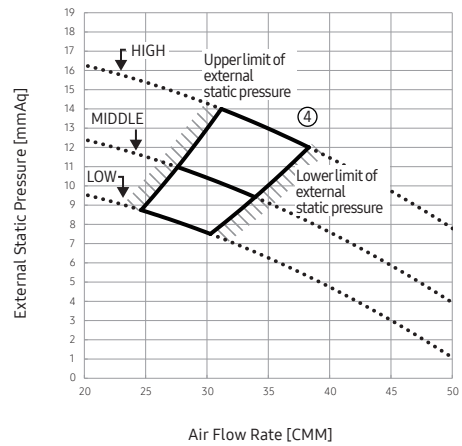

⑤	External Static Pressure(mmAq)	Option Code
	14<SP≤15	010054-1E5933-204747-331120

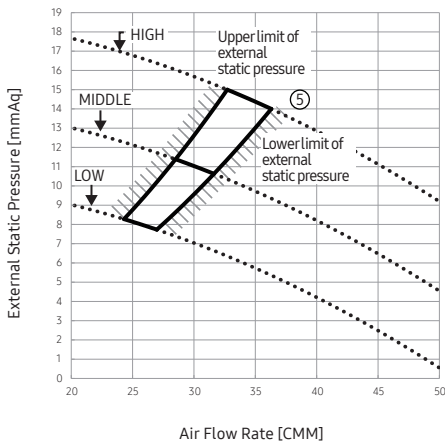

# 9. Piping Diagram

## MSP Duct

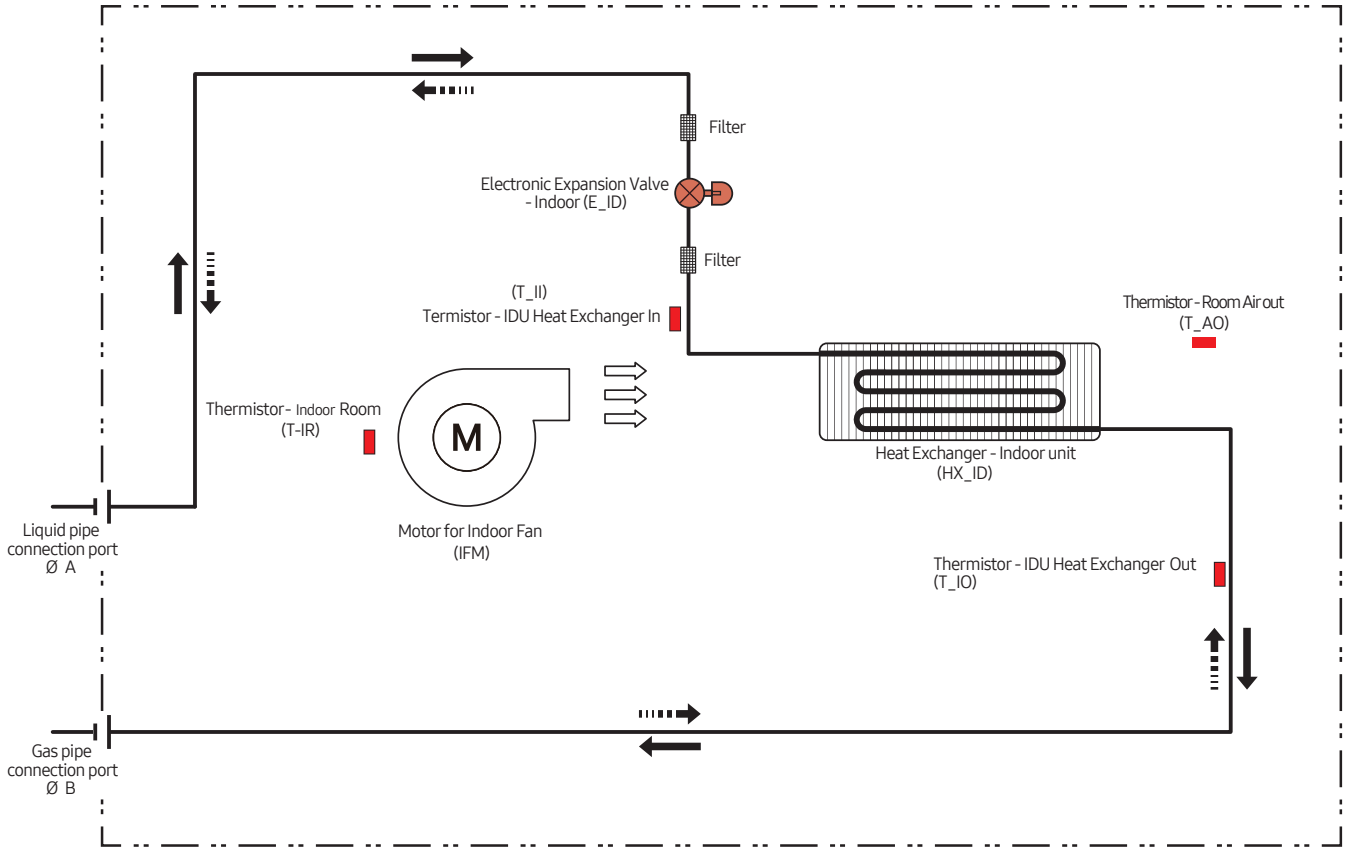

Refrigerant flow	
Cooling	Heating

# HSP Duct



---



<b>1. Specification</b>	<b>198</b>
<b>2. Summary Table</b>	<b>201</b>
<b>3. Capacity Table</b>	<b>203</b>
<b>4. Dimensional Drawing</b>	<b>205</b>
<b>5. Center of Gravity</b>	<b>209</b>
<b>6. Electrical Wiring Diagram</b>	<b>211</b>
<b>7. Sound Data</b>	<b>213</b>
<b>8. Fan Characteristics</b>	<b>217</b>
<b>9. Piping Diagram</b>	<b>228</b>

---

# Line-up

## HSP Duct

Capacity (kW)			
9.0	11.2	12.8	14.0
			

Capacity (kW)		
18.0	22.4	28.0
		

# 1. Specification

## HSP Duct

Model Name			AM090DNHDKG/EU	AM112DNHDKG/EU	
Power Supply			$\Phi$ , #, V, Hz	1,2,220~240,50/60	
Performance	Capacity	Cooling	kW	9.0	11.2
			Btu/h	30,700	38,200
		Heating	kW	10.0	12.5
			Btu/h	34,100	42,700
Power	Power Input	Cooling	W	145.0	130.0
		Heating	W	145.0	130.0
	Current Input	Cooling	A	1.2	1.2
		Heating	A	1.2	1.2
	Current	MCA	A	2.05	2.41
		MFA	A	15	15
Heat exchanger	Type		-	Fin & Tube	Fin & Tube
	Material	Fin	-	Al	Al
		Tube	-	Cu	Cu
	Fin Treatment		-	hydrophilic	hydrophilic
Fan	Type		-	Sirocco Fan	Sirocco Fan
	Quantity		EA	3	3
	Air Flow Rate	H/M/L	m <sup>3</sup> /min	29 / 25 / 22	32 / 26 / 20
			l/s	483 / 417 / 367	533 / 433 / 333
	External Pressure	Min/Std/Max	mmAq	0 / 3 / 20	3 / 6.2 / 20
			Pa	0 / 29.42 / 196.13	29.42 / 60.8 / 196.13
Fan Motor	Type		-	BLDC	BLDC
	Output x n		W	153	350
Piping Connections	Liquid Pipe		Type	Flare connection	Flare connection
			$\Phi$ , mm (inch)	9.52 (3/8)	9.52 (3/8)
	Gas Pipe		Type	Flare connection	Flare connection
			$\Phi$ , mm (inch)	15.88 (5/8)	15.88 (5/8)
Drain Pipe		$\Phi$ ,inch	VP25 (OD 32,ID 25)	VP25 (OD 32,ID 25)	
Wiring connections	Communication (Min.)		mm <sup>2</sup>	0.75	0.75
			-	F1, F2	F1, F2
Refrigerant	Type		-	R32	R32
	Control Method		-	EEV	EEV
Sound	Sound Pressure Level	H/M/L	dB(A)	34 / 31 / 28	
	Sound Power Level	Cooling		60	61
External Dimension	Net Weight		kg	34.2	44.5
	Shipping Weight		kg	38.9	51.1
	Net Dimensions (W×H×D)		mm	1,200 x 250 x 700	1,300 x 300 x 700
	Shipping Dimensions (W×H×D)		mm	1,429 x 320 x 779	1,529 x 370 x 779
Casing	Material		-	Steel	Steel
Additional Accessories	Drain pump	External Model	-	-	-
		Internal Model	-	Built in	Built in
		Max. lifting	mm / Liter/h	750 / 24	750 / 24
	Air Filter		-	-	-

### NOTE

- Specification may be subject to change without prior notice.
  - 1) Capacities are based on (Equivalent refrigerant piping 7.5m, Level differences 0m);
    - Cooling : Indoor temperature 27°C DB, 19°C WB / Outdoor temperature 35°C DB, 24°C WB
    - Heating : Indoor temperature 20°C DB, 15°C WB / Outdoor temperature 7°C DB, 6°C WB
  - 2) Sound level was acquired in an anechoic room. Thus actual noise level may be different depending on the installation conditions.
  - 3) These products contain R32 (GWP=675) which is fluorinated greenhouse gas.
  - 4) Select wire size based on the value of MCA

# 1. Specification

## HSP Duct

Model Name				AM128DNHDKG/EU	AM140DNHDKG/EU
Power Supply			Φ, #, V, Hz	1,2,220~240,50/60	1,2,220~240,50/60
Performance	Capacity	Cooling	kW	12.8	14.0
			Btu/h	43,700	47,800
		Heating	kW	13.8	16.0
			Btu/h	47,100	54,600
Power	Power Input	Cooling	W	185.0	220.0
		Heating		185.0	220.0
	Current Input	Cooling	A	1.3	1.5
		Heating		1.3	1.5
	Current	MCA	A	2.96	3.23
		MFA		15	15
Heat exchanger	Type		-	Fin & Tube	Fin & Tube
	Material	Fin	-	Al	Al
		Tube	-	Cu	Cu
	Fin Treatment		-	hydrophilic	hydrophilic
Fan	Type		-	Sirocco Fan	Sirocco Fan
	Quantity		EA	3	3
	Air Flow Rate	H/M/L	m <sup>3</sup> /min	37 / 30 / 22	41 / 34 / 25
			l/s	617 / 500 / 367	683 / 567 / 417
	External Pressure	Min/Std/Max	mmAq	3 / 6.2 / 20	3 / 6.2 / 20
			Pa	29.42 / 60.8 / 196.13	29.42 / 60.8 / 196.13
Fan Motor	Type		-	BLDC	BLDC
	Output x n		W	350	350
Piping Connections	Liquid Pipe		Type	Flare connection	Flare connection
			Φ, mm (inch)	9.52 (3/8)	9.52 (3/8)
	Gas Pipe		Type	Flare connection	Flare connection
			Φ, mm (inch)	15.88 (5/8)	15.88 (5/8)
Drain Pipe		Φ,inch	VP25 (OD 32,ID 25)	VP25 (OD 32,ID 25)	
Wiring connections	Communication (Min.)		mm <sup>2</sup>	0.75	0.75
			-	F1, F2	F1, F2
Refrigerant	Type		-	R32	R32
	Control Method		-	EEV	EEV
Sound	Sound Pressure Level	H/M/L	dB(A)	39 / 36 / 33	42 / 38 / 34
	Sound Power Level	Cooling		64	65
External Dimension	Net Weight		kg	44.5	44.5
	Shipping Weight		kg	51.1	51.1
	Net Dimensions (W×H×D)		mm	1,300 x 300 x 700	1,300 x 300 x 700
	Shipping Dimensions (W×H×D)		mm	1,529 x 370 x 779	1,529 x 370 x 779
Casing	Material		-	Steel	Steel
Additional Accessories	Drain pump	External Model	-	-	-
		Internal Model	-	Built in	Built in
		Max. lifting	mm / Liter/h	750 / 24	750 / 24
	Air Filter		-	-	-

### NOTE

- Specification may be subject to change without prior notice.
  - 1) Capacities are based on (Equivalent refrigerant piping 7.5m, Level differences 0m);
    - Cooling : Indoor temperature 27°C DB, 19°C WB / Outdoor temperature 35°C DB, 24°C WB
    - Heating : Indoor temperature 20°C DB, 15°C WB / Outdoor temperature 7°C DB, 6°C WB
  - 2) Sound level was acquired in an anechoic room. Thus actual noise level may be different depending on the installation conditions.
  - 3) These products contain R32 (GWP=675) which is fluorinated greenhouse gas.
  - 4) Select wire size based on the value of MCA

# 1. Specification

## HSP Duct

Model Name			AM180HEHDKG/EU	AM220HEHDKG/EU	AM280HEHDKG/EU	
Power Supply			Φ, #, V, Hz	1,2,220-240,50/60	1,2,220-240,50/60	1,2,220-240,50/60
Performance	Capacity	Cooling	kW	18.0	22.4	28.0
			Btu/h	61,400	76,400	95,500
		Heating	kW	20.0	25.0	31.5
			Btu/h	68,200	85,300	107,500
Power	Power Input	Cooling	W	340.0	530.0	790.0
		Heating		340.0	530.0	790.0
	Current Input	Cooling	A	1.90	3.80	5.90
		Heating		1.90	3.80	5.90
	Current	MCA	A	5.72	5.80	8.64
		MFA		15.00	15.00	15.00
Heat exchanger	Type		-	Fin & Tube	Fin & Tube	Fin & Tube
	Material	Fin	-	Al	Al	Al
		Tube	-	Cu	Cu	Cu
	Fin Treatment		-	hydrophilic	hydrophilic	hydrophilic
Fan	Type	Type	-	Sirocco Fan	Sirocco Fan	Sirocco Fan
	Quantity		ea	2	2	2
	Air Flow Rate	H/M/L	CMM	58.0 / 50.0 / 43.0	58.0 / 52.0 / 47.0	72.0 / 65.0 / 58.0
			l/s	966.67 / 833.33 / 716.67	966.67 / 866.67 / 783.33	1200.00 / 1083.33 / 966.67
	External Pressure	Min/Std/Max	mmAq	5.00 / 7.34 / 20.00	5.00 / 15.00 / 25.00	5.00 / 15.00 / 28.00
			Pa	49.00 / 71.93 / 196.00	49.03 / 147.10 / 245.17	49.03 / 147.10 / 274.59
Fan Motor	Model		-	BLDC	BLDC	BLDC
	Output x n		W	630	400	400
Piping Connections	Liquid Pipe	Type	-	Flare connection	Flare connection	Flare connection
		Φ, mm (inch)	-	9.52 (3/8)	9.52 (3/8)	9.52 (3/8)
	Gas Pipe	Type	-	Flare connection	Flare connection	Flare connection
		Φ, mm (inch)	-	19.05 (3/4)	19.05 (3/4)	22.22 (7/8)
	Heat insulation		-	Both liquid & gas pipes	Both liquid & gas pipes	Both liquid & gas pipes
Drain Pipe		Φ,mm	VP25 (OD 32, ID 25)	VP25 (OD 32, ID 25)	VP25 (OD 32, ID 25)	
Wiring connections	Communication	Min.	mm <sup>2</sup>	0.75	0.75	0.75
		Remark	-	F1, F2	F1, F2	F1, F2
Refrigerant	Type		-	R32	R32	R32
	Electronic Expansion Valve		-	EEV INCLUDED	EEV INCLUDED	EEV INCLUDED
Sound Level	Sound Pressure Level	H/M/L	dB(A)	43 / 39 / 35	45 / 43 / 41	48 / 46 / 43
	Sound Power Level	Cooling		80	82	85
Dimensions	Net Weight		kg	82.5	89.0	89.0
	Shipping Weight		kg	92.0	99.0	99.0
	Net Dimensions (W×H×D)		mm	1,350 x 450 x 850	1,240 x 470 x 1,040	1,240 x 470 x 1,040
	Shipping Dimensions (W×H×D)		mm	1,612 x 519 x 984	1,507 x 558 x 1,155	1,507 x 558 x 1,155
Casing	Material		-	Steel	Steel	Steel
Additional Accessories	Drain Pump		-	MDP-G075SP MDP-G075SQ	MDP-N047SNC1D	MDP-N047SNC1D
	Max. lifting Height / Displacement		mm / Liter/h	750 / 24	750 / 24	750 / 24
	Air Filter		-	-	-	-

### NOTE

- Specification may be subject to change without prior notice.
  - 1) Capacities are based on (Equivalent refrigerant piping 7.5m, Level differences 0m);
    - Cooling : Indoor temperature 27°C DB, 19°C WB / Outdoor temperature 35°C DB, 24°C WB
    - Heating : Indoor temperature 20°C DB, 15°C WB / Outdoor temperature 7°C DB, 6°C WB
  - 2) Sound level was acquired in an anechoic room. Thus actual noise level may be different depending on the installation conditions.
  - 3) These products contain R32 (GWP=675) which is fluorinated greenhouse gas.
  - 4) Select wire size based on the value of MCA

## 2. Summary Table

### HSP Duct

#### Performance Characteristics

Model Code	Fan Speed	Nominal Capacity [kW]			Airflow [CMM]	Sound Pressure [dBA]	Sound Power [dBA]	Static Pressure (Min/Std/Max) [mmAq]
		Cooling	Sensible	Heating				
AM090DNHDKG/EU	High	9.0	7.1	10.0	29	34	60	0 / 3 / 20
	Mid	7.9	6.2	9.3	25	31	-	
	Low	7.0	5.5	8.7	22	28	-	
AM112DNHDKG/EU	High	11.2	8.6	12.5	32	36	61	3 / 6.2 / 20
	Mid	9.3	7.1	11.3	26	33	-	
	Low	7.2	5.5	9.9	20	30	-	
AM128DNHDKG/EU	High	12.8	9.9	13.8	37	39	64	3 / 6.2 / 20
	Mid	10.6	8.2	12.4	30	36	-	
	Low	7.8	6.0	10.6	22	33	-	
AM140DNHDKG/EU	High	14.0	10.8	16.0	41	42	65	3 / 6.2 / 20
	Mid	11.9	9.2	14.6	34	38	-	
	Low	8.8	6.8	12.5	25	34	-	

#### NOTE

- Sound data is based on cooling operation.

#### Electric Characteristics

Model Code	Power Supply (Φ, #, V, Hz)	Power Input (W)	Current Input (A)	MCA (A)	MFA (A)	FLA (A)
AM090DNHDKG/EU	1,2,220~240,50/60	145	1.2	2.05	15	1.64
AM112DNHDKG/EU		130	1.2	2.41	15	1.93
AM128DNHDKG/EU		185	1.3	2.96	15	2.37
AM140DNHDKG/EU		220	1.5	3.23	15	2.59

#### NOTE

- MCA : Minimum circuit amperes
- MFA : Maximum fuse amperes
- Select wire size based on the value of MCA

## 2. Summary Table

### HSP Duct

#### Performance Characteristics

Model Code	Fan Speed	Nominal Capacity [kW]			Airflow [CMM]	Sound Pressure [dBA]	Sound Power [dBA]	Static Pressure (Min/Std/Max) [mmAq]
		Cooling	Sensible	Heating				
AM180HEHDKG/EU	High	18.0	13.5	20.0	58	43	80	5 / 7 / 20
	Mid	15.8	11.9	18.6	50	39	-	
	Low	13.7	10.3	17.2	43	35	-	
AM220HEHDKG/EU	High	22.4	17.1	20.0	58	45	82	5 / 15 / 25
	Mid	20.4	15.6	18.9	52	43	-	
	Low	18.6	14.2	18.0	47	41	-	
AM280HEHDKG/EU	High	28.0	21.8	31.5	72	48	85	5 / 15 / 28
	Mid	25.6	19.9	29.9	65	46	-	
	Low	23.1	18.0	28.3	58	43	-	

#### NOTE

- Sound data is based on cooling operation.

#### Electric Characteristics

Model Code	Power Supply (Φ, #, V, Hz)	Power Input (W)	Current Input (A)	MCA (A)	MFA (A)	FLA (A)
AM180HEHDKG/EU	1,2,220~240,50/60	340	1.9	TBD	TBD	TBD
AM220HEHDKG/EU		530	3.8	TBD	TBD	TBD
AM280HEHDKG/EU		790	5.9	TBD	TBD	TBD

#### NOTE

- MCA : Minimum circuit amperes
- MFA : Maximum fuse amperes
- Select wire size based on the value of MCA

# 3. Capacity Table

## HSP Duct

### Cooling

TC : Total Capacity, SHC : Sensible Heat Capacity

Capacity Index	Outdoor Air Temp. ( °C,DB )	Indoor temperature													
		20(°C,DB)		23(°C,DB)		26(°C,DB)		27(°C,DB)		28(°C,DB)		30(°C,DB)		32(°C,DB)	
		14(°C,WB)		16(°C,WB)		18(°C,WB)		19(°C,WB)		20(°C,WB)		22(°C,WB)		24(°C,WB)	
		TC	SHC	TC	SHC	TC	SHC	TC	SHC	TC	SHC	TC	SHC	TC	SHC
090	35	6.2	5.7	7.3	6.5	8.4	6.9	9.0	7.1	9.3	7.2	10.0	7.2	10.6	7.0
112	35	7.7	6.8	9.1	7.7	10.5	8.2	11.2	8.6	11.6	8.8	12.4	8.7	13.2	8.5
128	35	8.8	7.8	10.4	8.9	12.0	9.5	12.8	9.9	13.3	9.9	14.2	9.9	15.1	9.7
140	35	9.7	8.6	11.4	9.7	13.1	10.5	14.0	10.8	14.5	10.8	15.5	10.8	16.5	10.6

### Heating

TC : Total Capacity (kW)

Capacity Index	Outdoor Air Temp. ( °C )		Indoor temperature ( °C,DB )						
			14(°C,DB)	16(°C,DB)	18(°C,DB)	20(°C,DB)	22(°C,DB)	24(°C,DB)	27(°C,DB)
			TC	TC	TC	TC	TC	TC	TC
	DB	WB	kW	kW	kW	kW	kW	kW	kW
090	7.0	6.0	10.9	10.3	10.1	10.0	9.2	8.4	7.8
112	7.0	6.0	13.6	12.9	12.7	12.5	11.5	10.6	9.9
128	7.0	6.0	15.0	14.2	14.0	13.8	12.7	11.7	10.9
140	7.0	6.0	17.4	16.5	16.2	16.0	14.8	13.5	12.6

### NOTE

- The performance table shows the average value of each conditions.

# 3. Capacity Table

## HSP Duct

### Cooling

TC : Total Capacity, SHC : Sensible Heat Capacity

Capacity Index	Outdoor Air Temp. ( °C,DB )	Indoor temperature													
		20(°C,DB)		23(°C,DB)		26(°C,DB)		27(°C,DB)		28(°C,DB)		30(°C,DB)		32(°C,DB)	
		14(°C,WB)		16(°C,WB)		18(°C,WB)		19(°C,WB)		20(°C,WB)		22(°C,WB)		24(°C,WB)	
		TC	SHC	TC	SHC	TC	SHC	TC	SHC	TC	SHC	TC	SHC	TC	SHC
180	35	12.7	10.8	15.0	12.2	17.0	13.1	18.0	13.5	19.1	13.8	21.1	14.0	21.6	13.9
220	35	15.8	13.8	18.7	15.4	21.2	16.6	22.4	17.1	23.9	17.7	26.4	18.5	27.0	18.0
280	35	19.7	17.6	23.3	19.6	26.5	21.2	28.0	21.8	29.9	22.6	32.7	23.5	33.7	23.0

### Heating

TC : Total Capacity (kW)

Capacity Index	Outdoor Air Temp. ( °C )		Indoor temperature ( °C,DB )						
			14(°C,DB)	16(°C,DB)	18(°C,DB)	20(°C,DB)	22(°C,DB)	24(°C,DB)	27(°C,DB)
			TC	TC	TC	TC	TC	TC	TC
	DB	WB	kW	kW	kW	kW	kW	kW	
180	7.0	6.0	23.8	22.6	21.4	20.0	19.4	18.8	18.2
220	7.0	6.0	30.6	28.8	27.0	25.0	24.4	23.6	22.8
280	7.0	6.0	37.7	35.7	33.7	31.5	30.4	29.5	28.6

### NOTE

- The performance table shows the average value of each conditions.

# 4. Dimensional Drawing

## HSP Duct

### AM090DNHDKG/EU

Units : mm [inches]

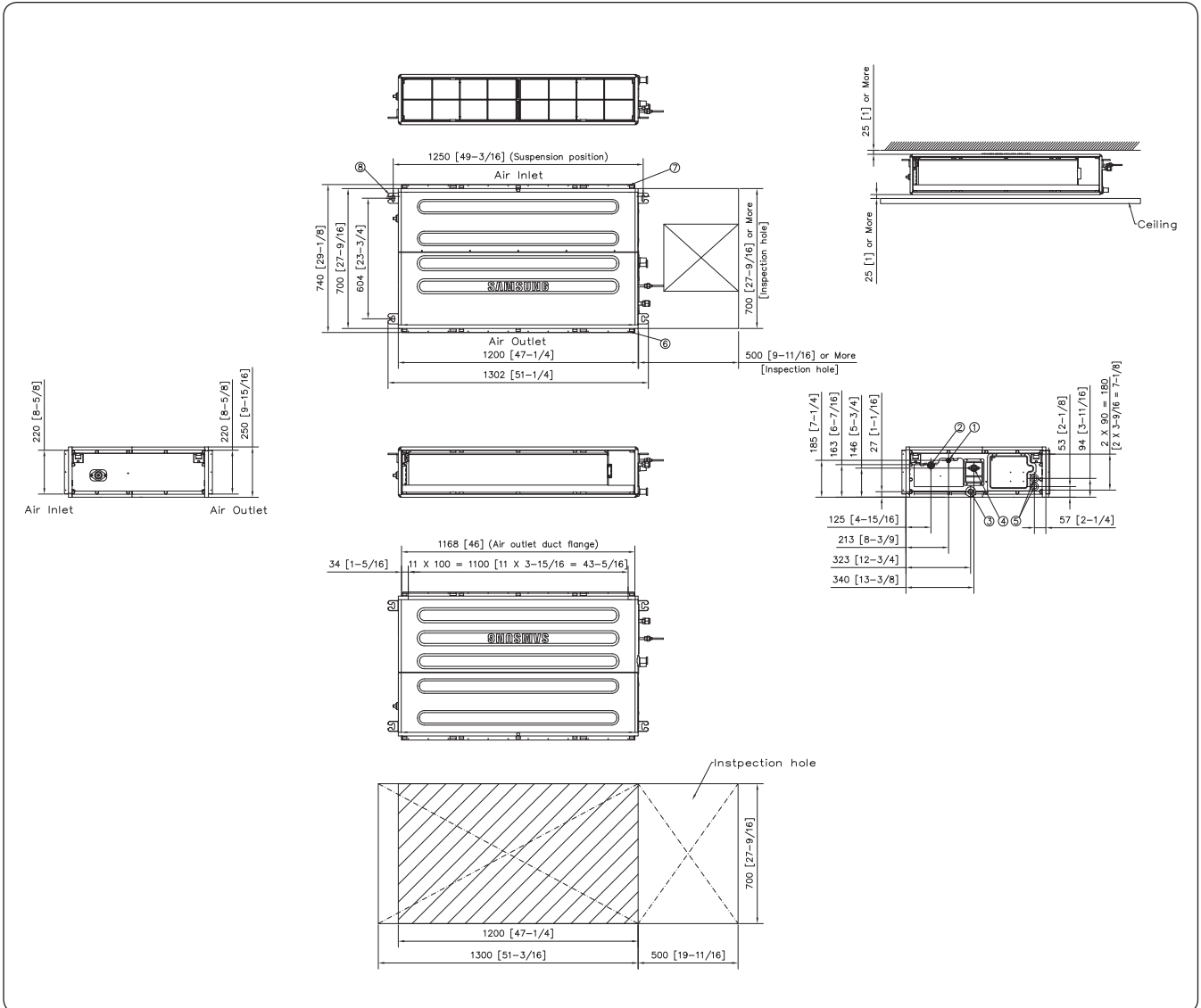

No.	Name	Description
①	Liquid pipe connection	Ø9.52 (3/8)
②	Gas pipe connection	Ø15.88 (5/8)
③	Drain pipe connection (Without drain pump)	VP25 (OD 32, ID 25)
④	Drain pipe connection (With drain pump)	-
⑤	Power & Communication Conduits	-
⑥	Air discharge grille flange	-
⑦	Air suction flange	-
⑧	Hook	Use M8~M10 bolt(4ea)

# 4. Dimensional Drawing

## HSP Duct

AM112DNHDKG/EU, AM128DNHDKG/EU, AM140DNHDKG/EU

Units : mm [inches]

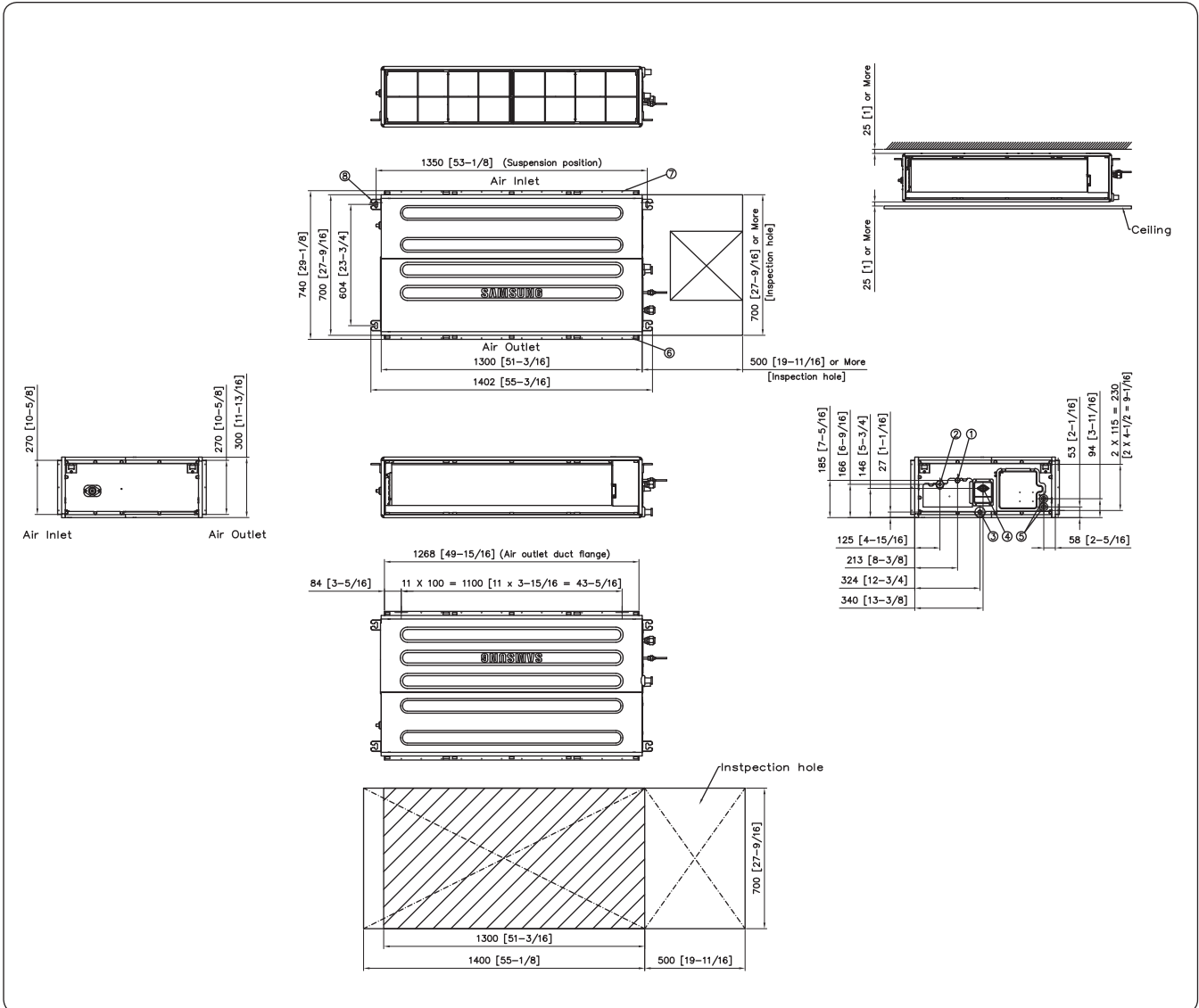

No.	Name	Description
①	Liquid pipe connection	Ø9.52 (3/8)
②	Gas pipe connection	Ø15.88 (5/8)
③	Drain pipe connection (Without drain pump)	VP25 (OD 32, ID 25)
④	Drain pipe connection (With drain pump)	-
⑤	Power & Communication Conduits	-
⑥	Air discharge grille flange	-
⑦	Air suction flange	-
⑧	Hook	Use M8~M10 bolt(4ea)

# 4. Dimensional Drawing

## HSP Duct

AM180HEHDKG/EU, AM220HEHDKG/EU

Units : mm [inches]

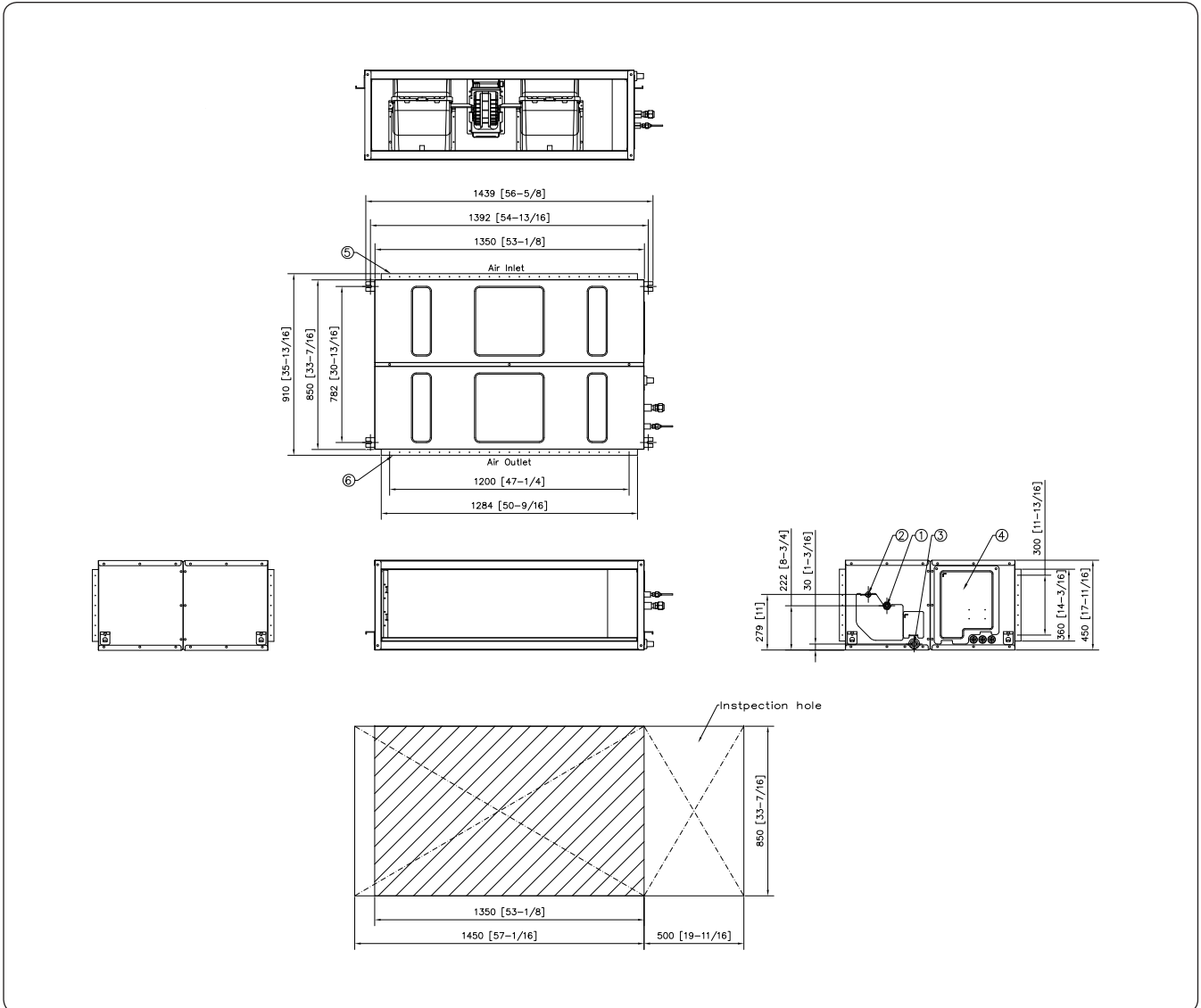

No.	Name	Description
①	Gas pipe connection	Φ19.05 (3/4)
②	Liquid pipe connection	Φ9.52 (3/8)
③	Drain pipe connection without drain pump	VP25 (OD 32, ID 25)
④	Control Unit	-
⑤	Return air side	-
⑥	Air discharge flange	-

# 4. Dimensional Drawing

## HSP Duct

### AM280HEHDKG/EU

Units : mm [inches]

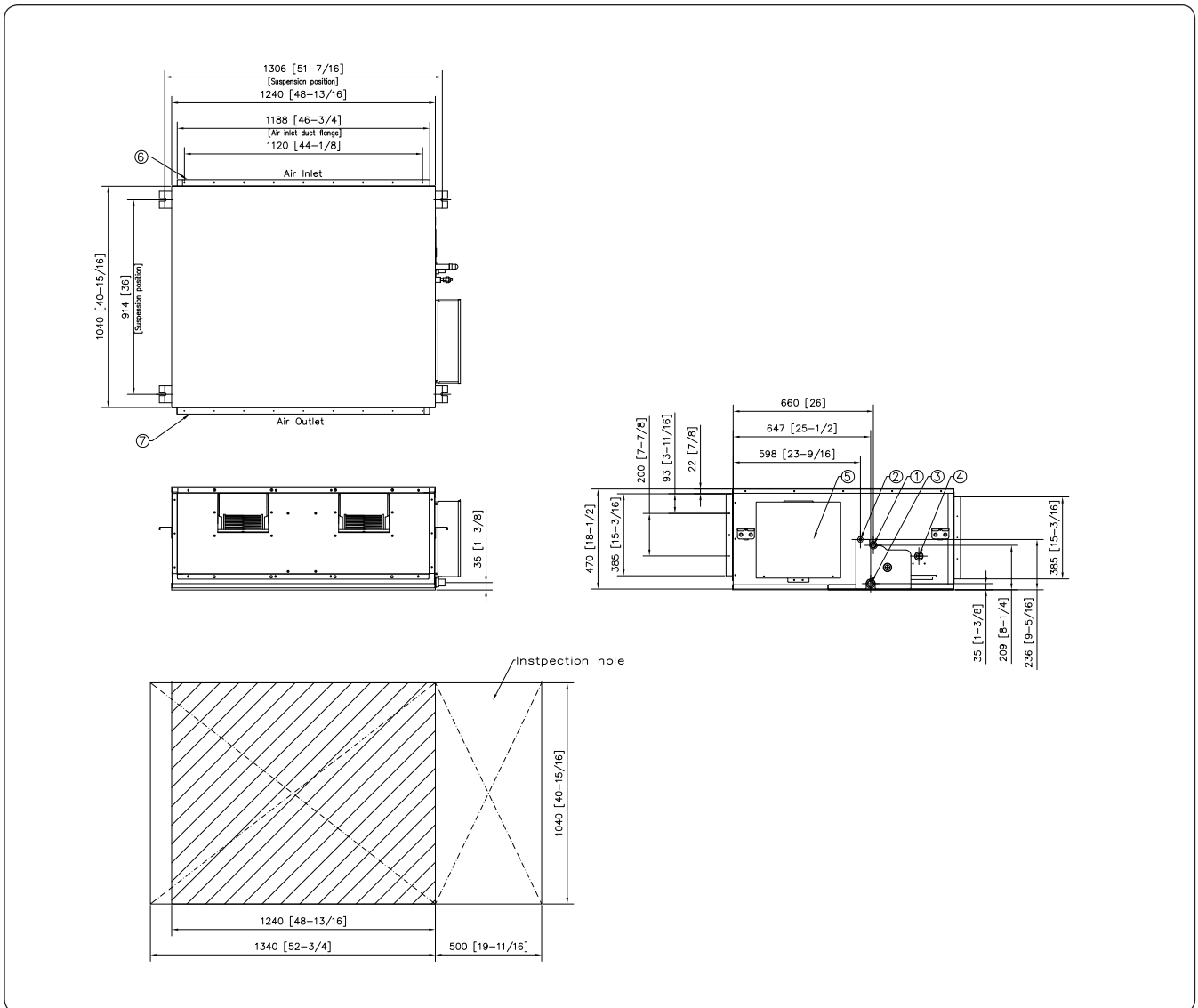

No.	Name	Description
①	Gas pipe connection	Φ22.22 (7/8)
②	Liquid pipe connection	Φ9.52 (3/8)
③	Drain pipe connection without drain pump	VP25 (OD 32, ID 25)
④	Drain pipe connection with drain pump	-
⑤	Control Unit	-
⑥	Return air side	-
⑦	Air discharge flange	-

# 5. Center of Gravity

## HSP Duct

Units : mm [inches]

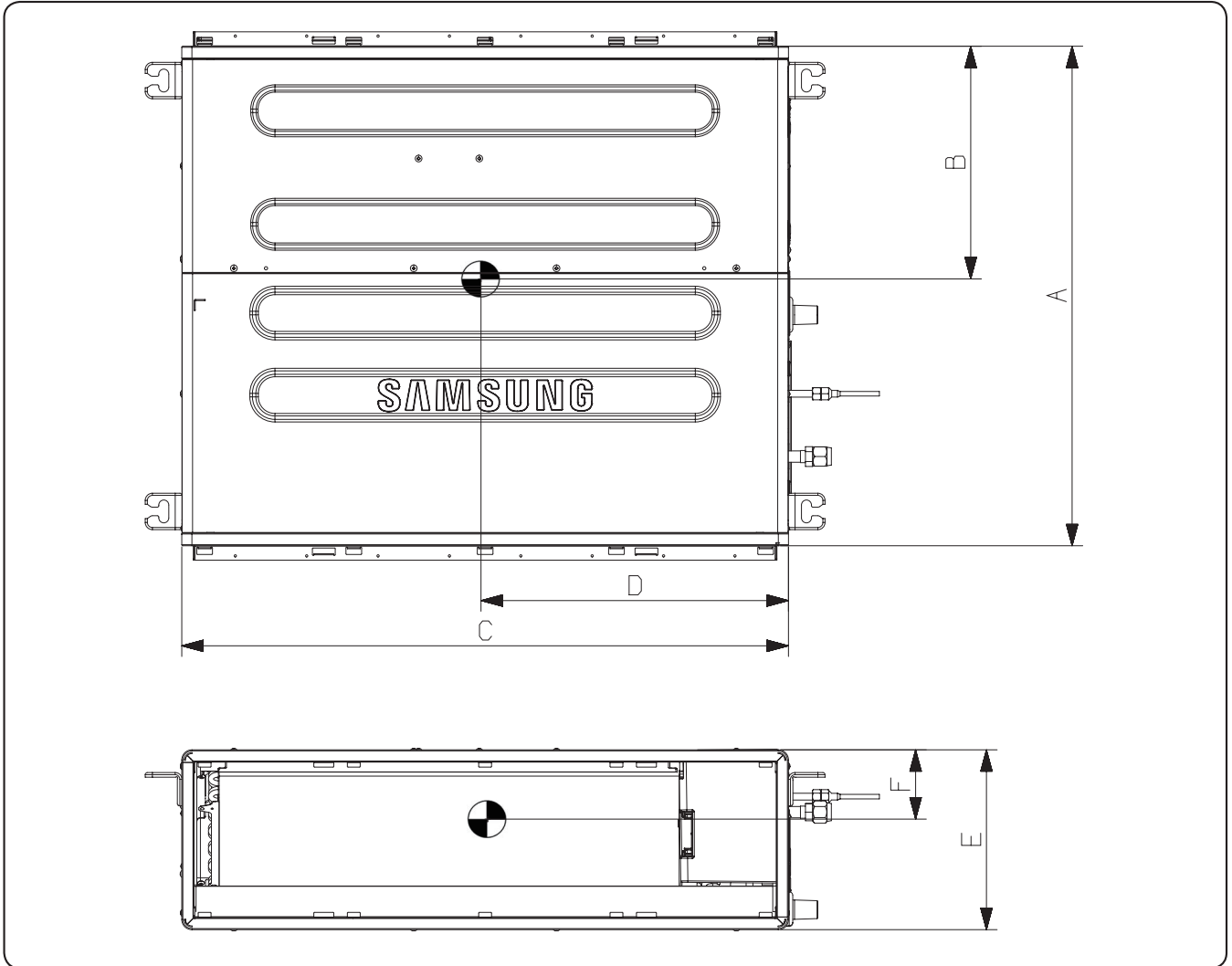

Model	A	B	C	D	E	F
AM090DNHDKG/EU	700 [27-9/16]	265 [10-7/16]	1200 [47-1/4]	540 [21-17/64]	250 [9-13/16]	125 [4-15/16]
AM112DNHDKG/EU, AM128DNHDKG/EU AM140DNHDKG/EU	700 [27-9/16]	265 [10-7/16]	1300 [51-3/16]	625 [24-39/64]	300 [11-13/16]	150 [5-15/16]

## 5. Center of Gravity

---

HSP Duct

---

Units : mm [inches]

TBD

---

# 6. Electrical Wiring Diagram

HSP Duct

AM090DNHDKG/EU, AM112DNHDKG/EU, AM128DNHDKG/EU, AM140DNHDKG/EU

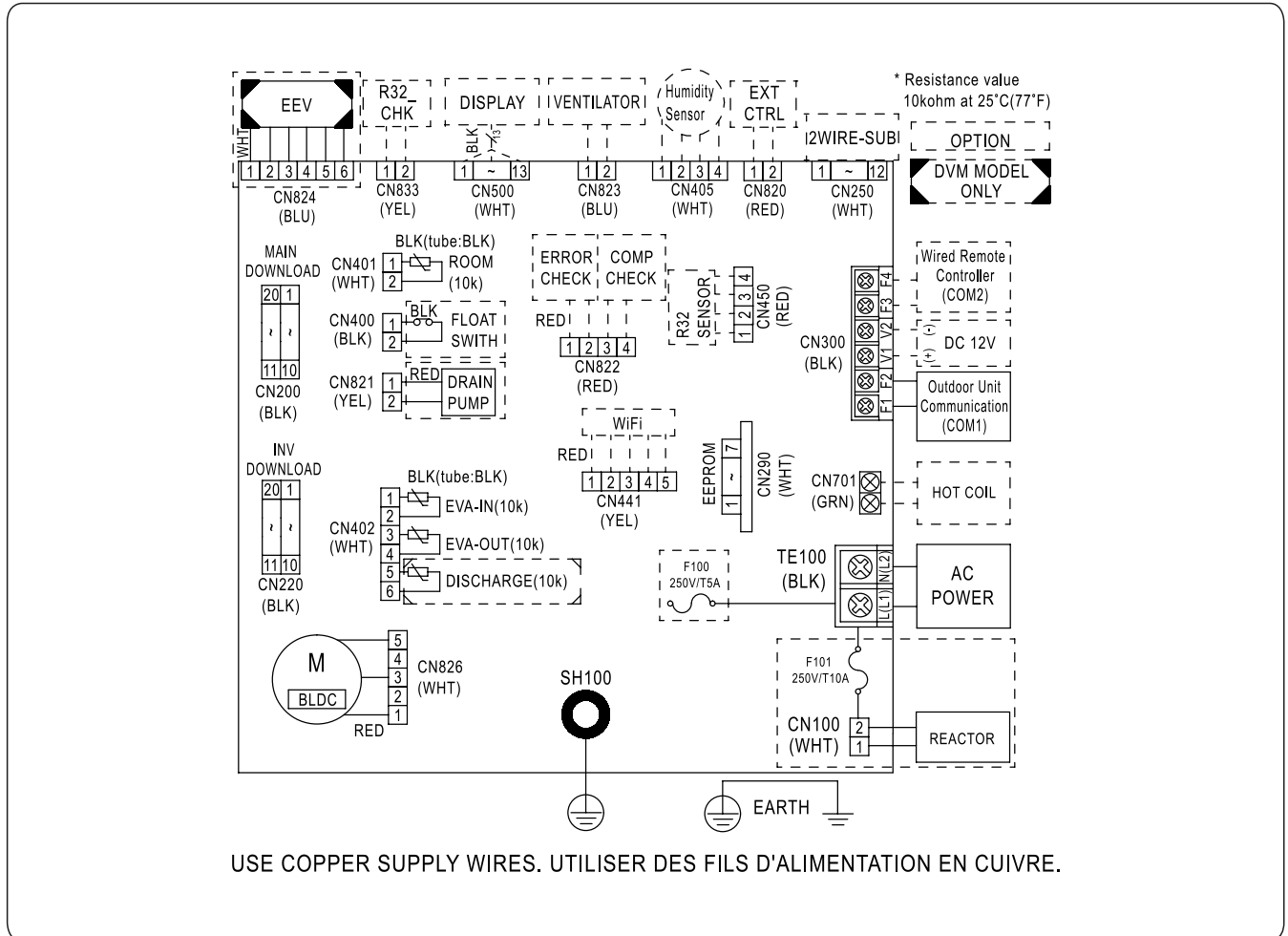

EEV	Electronic Expansion Valve	EVA-IN(10K)	Thermistor - IDU heat exchanger In	DISCHARGE(10K)	Thermistor - Indoor Discharge Air
M-BLDC	Motor for Indoor Fan	EVA-OUT(10K)	Thermistor - IDU heat exchanger Out	EXT CTRL	External Control
ROOM(10K)	Thermistor - Indoor Room				

## NOTE

- This wiring diagram applies only to the Indoor unit.
- Symbols show as follow :  
blk: black, red: red, blu: blue, wht: white, yel: yellow, brn: brown, sky: skyblue: grn: green
- For connection wiring indoor-outdoor transmission F1-F2, indoor-wired remote controller transmission F3-F4.
- ⊥ Protective earth(screw), □□□□ : connector,  $\frac{N}{\text{---}}$  : The wire quantity

# 6. Electrical Wiring Diagram

HSP Duct

AM180HEHDKG/EU, AM220HEHDKG/EU, AM280HEHDKG/EU

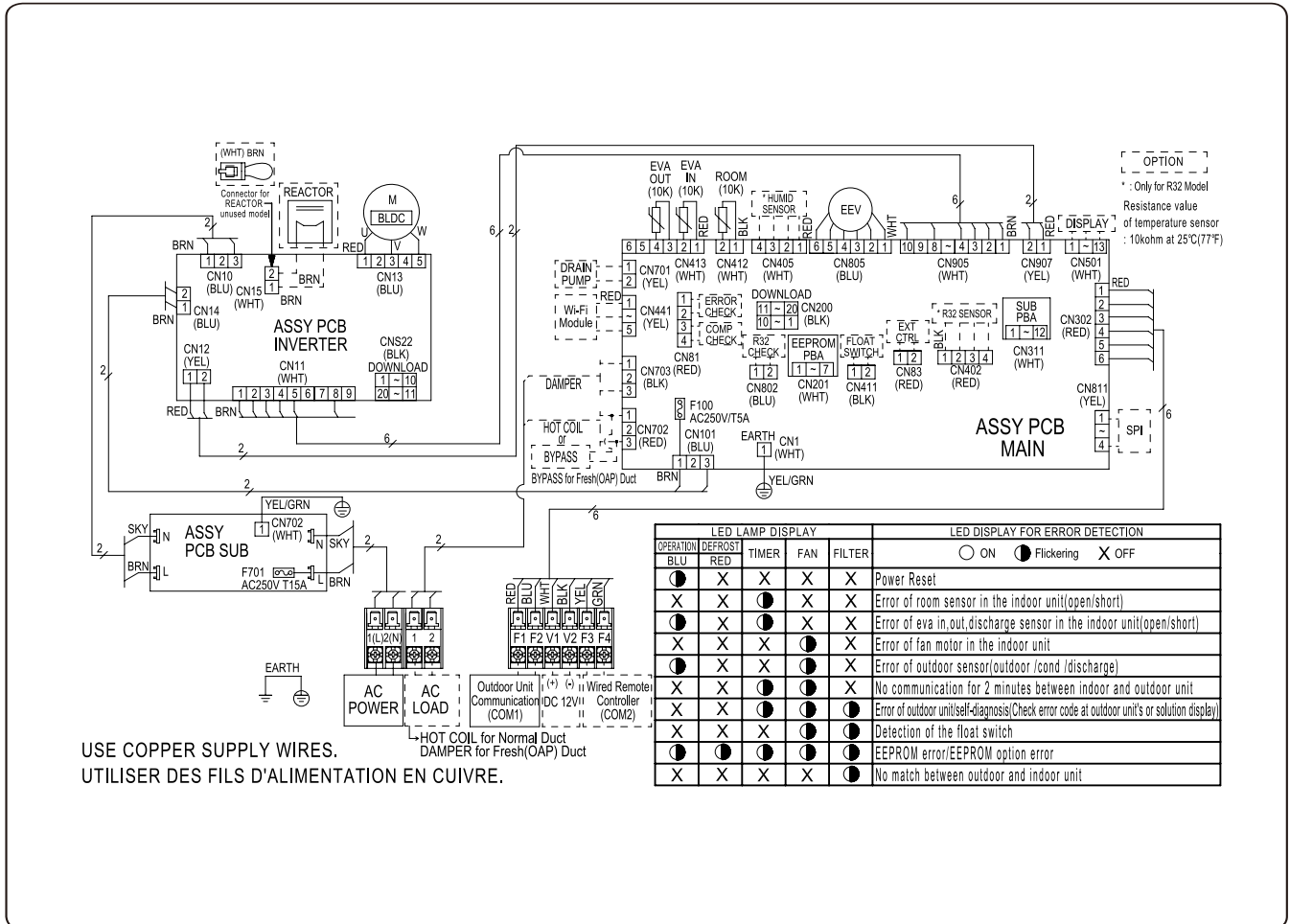

F100	Fuse	ROOM(10K)	Thermistor - Indoor Room
EEV	Electronic Expansion Valve	EVA IN (10K)	Thermistor - IDU heat exchanger In
M-BLDC	Motor for Indoor Fan	EVA OUT (10K)	Thermistor - IDU heat exchanger Out
ERROR CHECK	Contact output port for error check	EEPROM	EEPROM SUB PBA
COMP CHECK	Contact output port for compressor operation check	SUB PBA	SUB PBA for wired remote control communication
EXTERNAL CTRL	Input port for external contact control	DAMPER	Contact output port for Damper control
VENTILATOR	Contact output port for Ventilator control	HOT COIL	Contact output port for Hot coil control
BYPASS	Contact output port for Bypass control		

## NOTE

- This wiring diagram applies only to the Indoor unit.
- Symbols show as follow : BLK: black, RED: red, BLU: blue, WHT: white, YEL: yellow, GRN: green
- For connection wiring indoor-outdoor transmission F1-F2, indoor-wired remote controller transmission F3-F4.
- ⊕ Protective earth(screw), □ : connector,  $\frac{N}{\times}$  : The wire quantity

# 7. Sound Data

## HSP Duct

### Sound pressure level

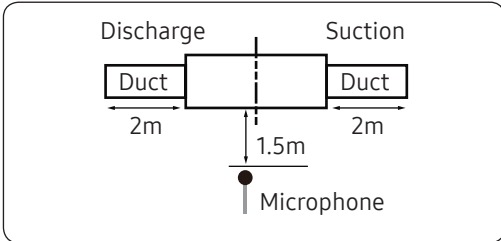

Unit: dB(A)

MODEL	High	Mid	Low
AM090DNHDKG/EU	34	31	28
AM112DNHDKG/EU	36	33	30
AM128DNHDKG/EU	39	36	33
AM140DNHDKG/EU	42	38	34

- NR Curve

1) AM090DNHDKG/EU

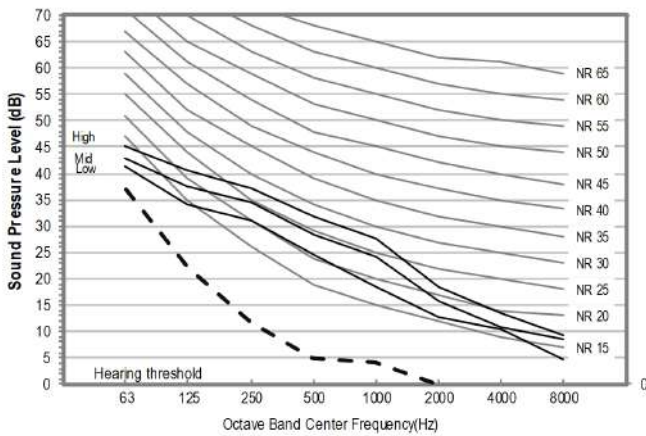

2) AM112DNHDKG/EU

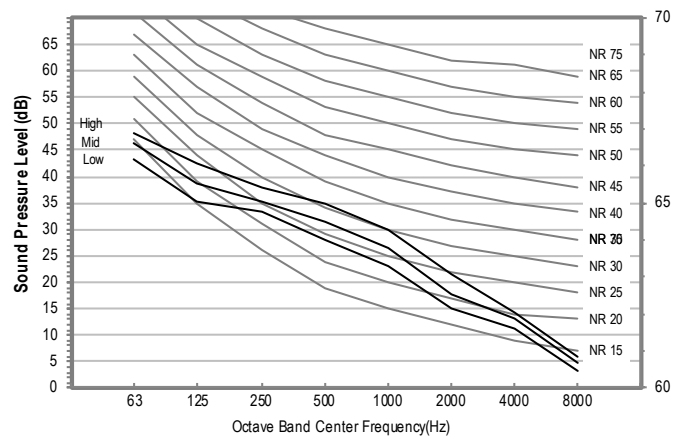

3) AM128DNHDKG/EU

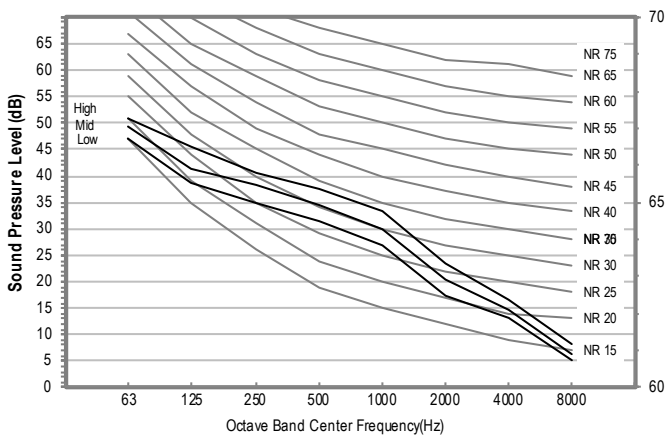

4) AM140DNHDKG/EU

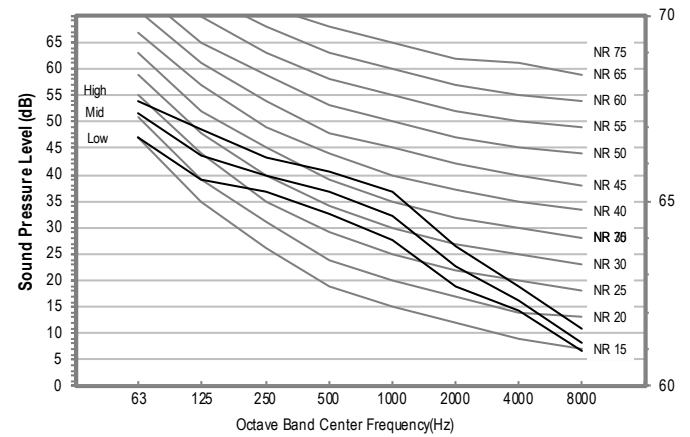

### NOTE

- Specifications may be subject to change without prior notice.
  - Sound pressure level is obtained in an anechoic room.
  - Sound pressure level is a relative value, depending on the distance and acoustic environment.
  - Sound pressure level may differ depending on operation condition.
  - dBA = A weighted sound pressure level
  - Reference acoustic pressure 0 dB = 20μPa

# 7. Sound Data

## HSP Duct

### Sound pressure level

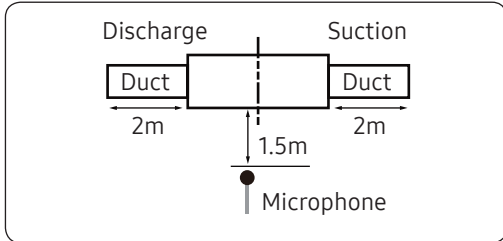

Unit: dB(A)

MODEL	High	Mid	Low
AM180EHDKG/EU	43	39	35
AM220EHDKG/EU	45	43	41
AM280EHDKG/EU	48	46	43

- NR Curve

1) AM180EHDKG/EU

2) AM220EHDKG/EU

3) AM280EHDKG/EU

# TBD

### NOTE

- Specifications may be subject to change without prior notice.
  - Sound pressure level is obtained in an anechoic room.
  - Sound pressure level is a relative value, depending on the distance and acoustic environment.
  - Sound pressure level may differ depending on operation condition.
  - dBA = A weighted sound pressure level
  - Reference acoustic pressure 0 dB = 20μPa

# 7. Sound Data

## HSP Duct

### Sound Power level



#### NOTE

- Specifications may be subject to change without prior notice
  - Sound power level is an absolute value that a sound source generates.
  - dBA = A-weighted sound power level.
  - Reference power : 1pW.
  - Measured according to ISO 3741.

Unit: dB(A)

Model	Power
AM090DNHDKG/EU	60
AM112DNHDKG/EU	61
AM128DNHDKG/EU	64
AM140DNHDKG/EU	65

#### • NR Curve

1) AM090DNHDKG/EU

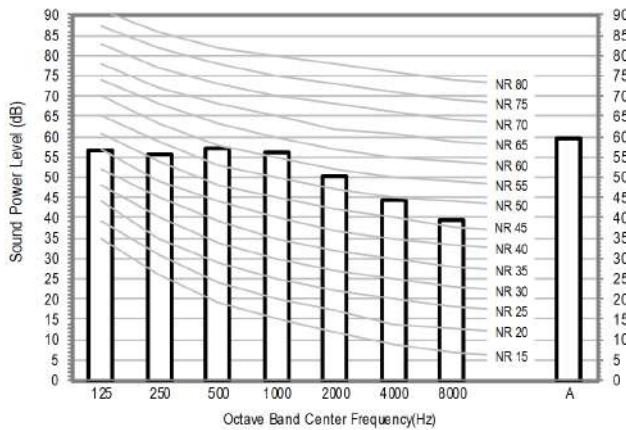

2) AM112DNHDKG/EU

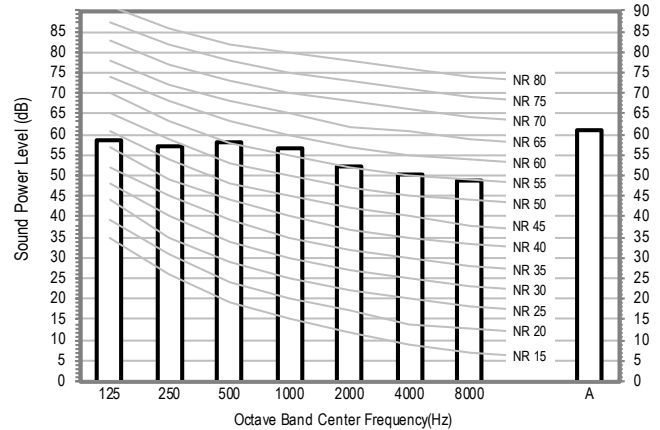

3) AM128DNHDKG/EU

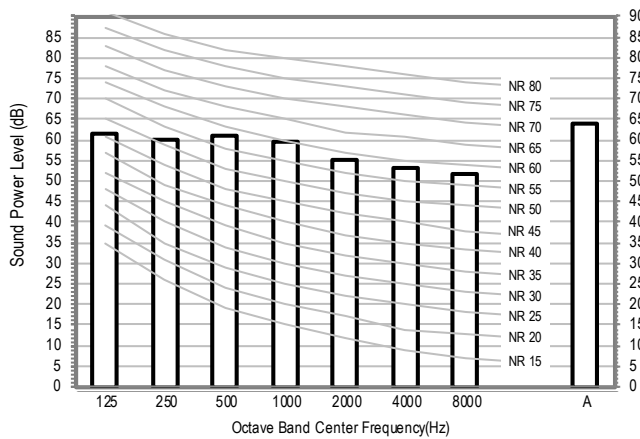

4) AM140DNHDKG/EU

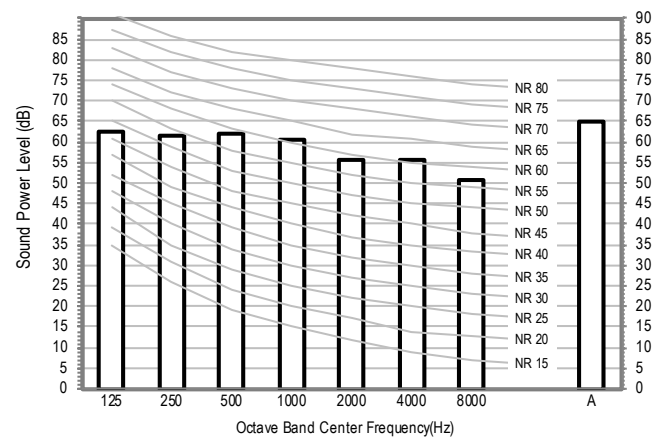

# 7. Sound Data

---

## HSP Duct

---

### Sound Power level

 **NOTE**

- Specifications may be subject to change without prior notice
  - Sound power level is an absolute value that a sound source generates.
  - dBA = A-weighted sound power level.
  - Reference power : 1pW.
  - Measured according to ISO 3741.

Unit: dB(A)

Model	Power
AM180EHDKG/EU	80
AM220EHDKG/EU	
AM280EHDKG/EU	

- NR Curve

1) AM180EHDKG/EU

2) AM220EHDKG/EU

TBD

3) AM280EHDKG/EU

# 8. Fan Characteristics

## HSP Duct

### AM090DNHDKG/EU

①	External Static Pressure(mmAq)	Option Code
	0<SP≤3 (Std.)	010054-1E546C-205A5A-331100

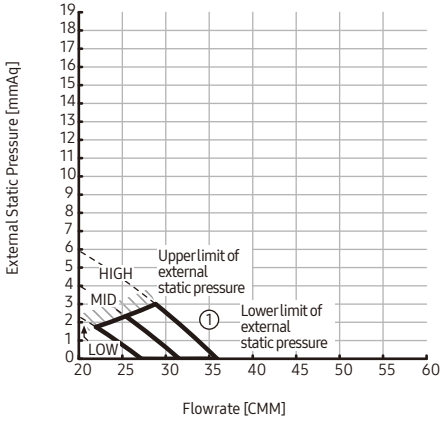

②	External Static Pressure(mmAq)	Option Code
	3<SP≤6	010054-1E55E1-205A5A-331100

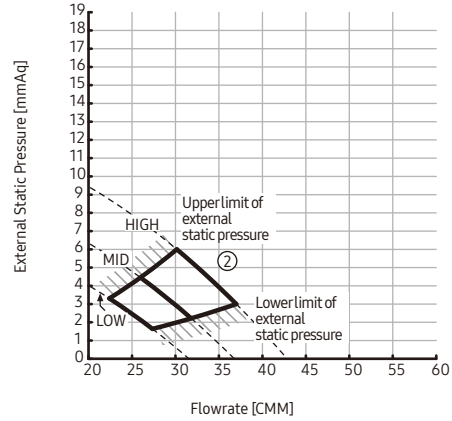

③	External Static Pressure(mmAq)	Option Code
	6<SP≤9	010054-1E5945-205A5A-331100

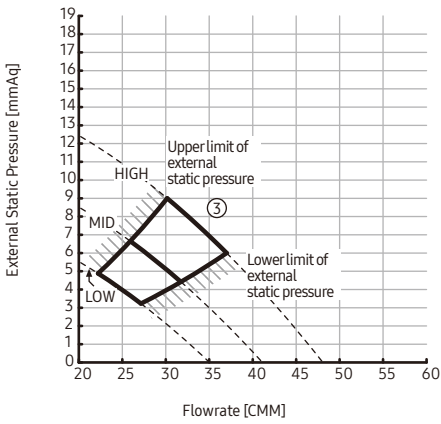

④	External Static Pressure(mmAq)	Option Code
	9<SP≤12	010054-1E599A-205A5A-331100

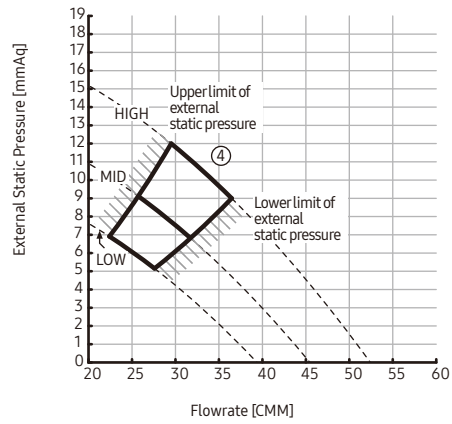

⑤	External Static Pressure(mmAq)	Option Code
	12<SP≤15	010054-1E59ED-205A5A-331100

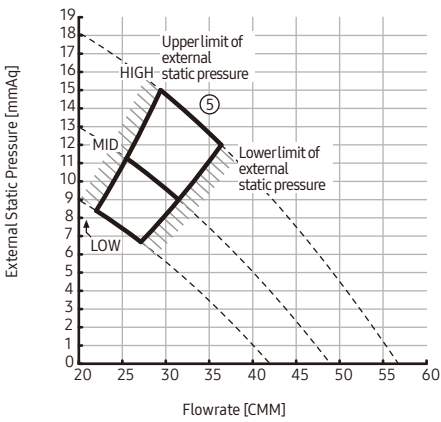

⑥	External Static Pressure(mmAq)	Option Code
	15<SP≤17	010054-1E5E10-205A5A-331100

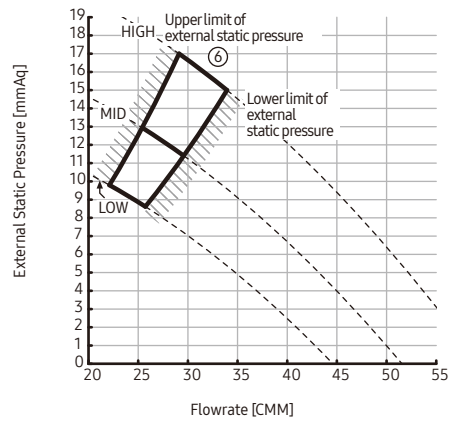

# 8. Fan Characteristics

## HSP Duct

### AM090DNHDKG/EU

⑦	External Static Pressure(mmAq)	Option Code
	17<SP≤19	010054-1E5E35-205A5A-331100

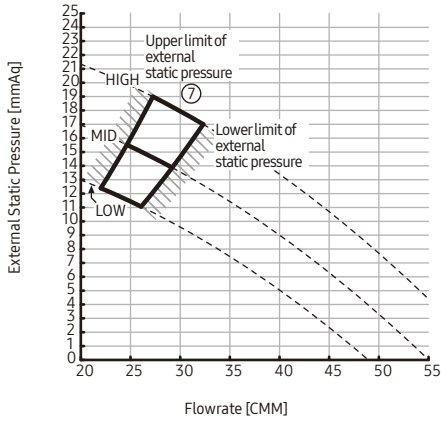

⑧	External Static Pressure(mmAq)	Option Code
	19<SP≤20	010054-1E5E55-205A5A-331100

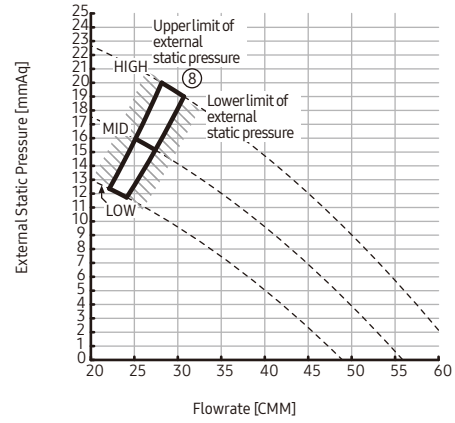

# 8. Fan Characteristics

## HSP Duct

### AM112DNHDKG/EU

①	External Static Pressure(mmAq)	Option Code
	3<SP≤6.2	010054-1E5439-207070-331120

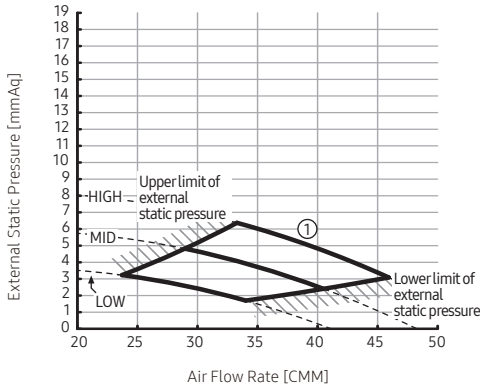

②	External Static Pressure(mmAq)	Option Code
	6.2<SP≤9	010054-1E548B-207070-331120

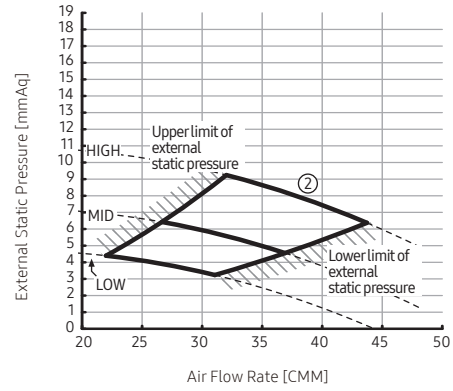

③	External Static Pressure(mmAq)	Option Code
	9<SP≤11	010054-1E54CB-207070-331120

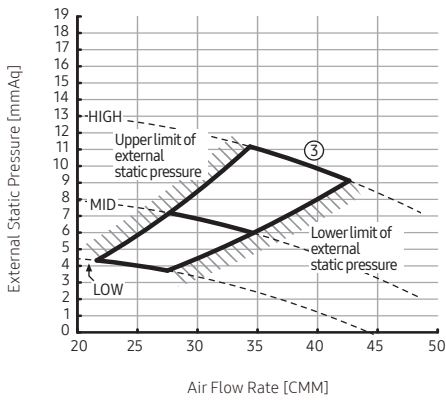

④	External Static Pressure(mmAq)	Option Code
	11<SP≤13	010054-1E54FD-207070-331120

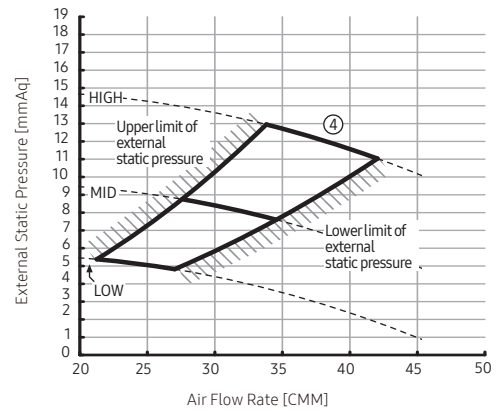

⑤	External Static Pressure(mmAq)	Option Code
	13<SP≤15	010054-1E582E-207070-331120

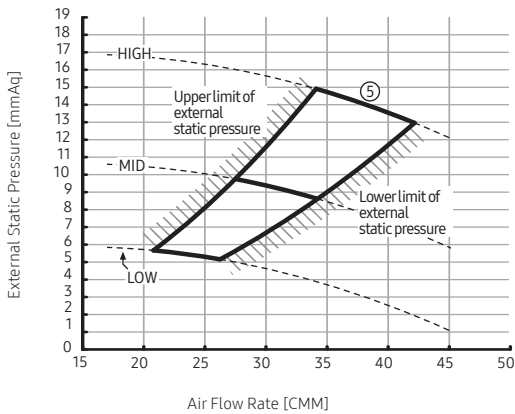

⑥	External Static Pressure(mmAq)	Option Code
	15<SP≤17	010054-1E585F-207070-331120

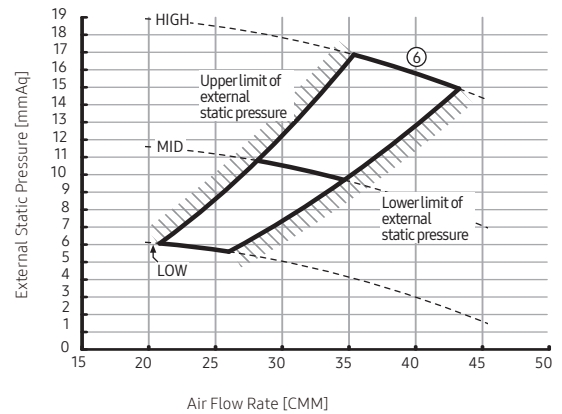

# 8. Fan Characteristics

## HSP Duct

### AM112DNHDKG/EU

⑦	External Static Pressure(mmAq)	Option Code
	17<SP≤19	010054-1E5973-207070-331120

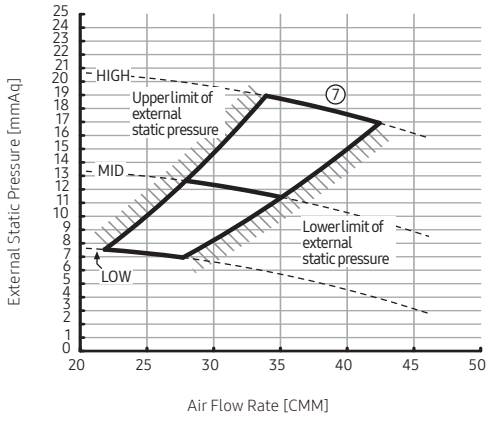

⑧	External Static Pressure(mmAq)	Option Code
	19<SP≤20	010054-1E5991-207070-331120

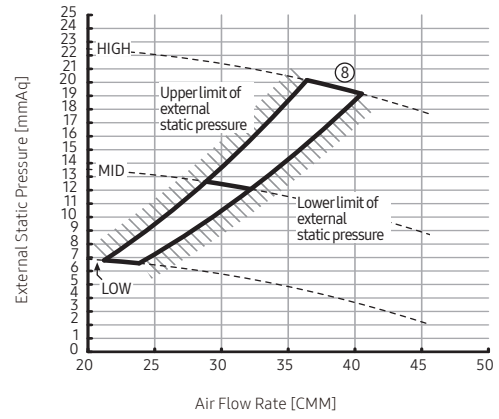

# 8. Fan Characteristics

## HSP Duct

### AM128DNHDKG/EU

①	External Static Pressure(mmAq)	Option Code
	3<SP≤6.2	010054-1E5469-208080-331120

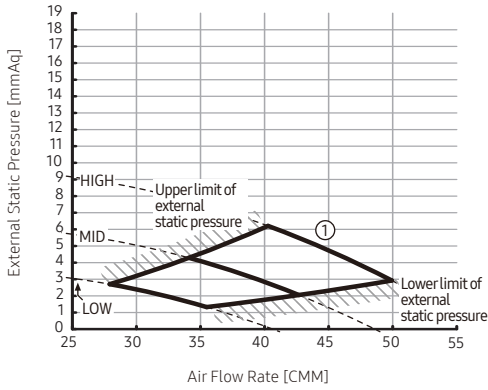

②	External Static Pressure(mmAq)	Option Code
	6.2<SP≤9	010054-1E54BA-208080-331120

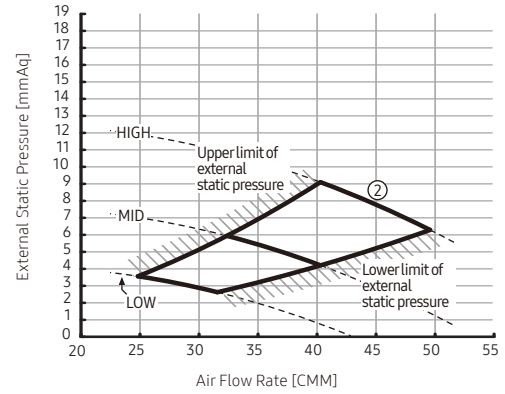

③	External Static Pressure(mmAq)	Option Code
	9<SP≤11	010054-1E54EC-208080-331120

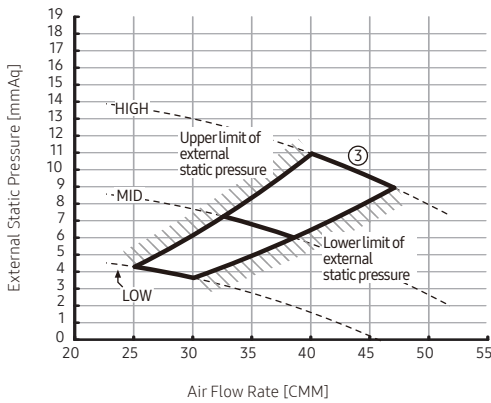

④	External Static Pressure(mmAq)	Option Code
	11<SP≤13	010054-1E581D-208080-331120

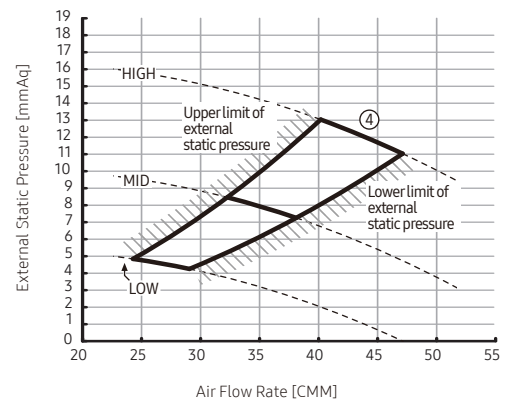

⑤	External Static Pressure(mmAq)	Option Code
	13<SP≤15	010054-1E584F-208080-331120

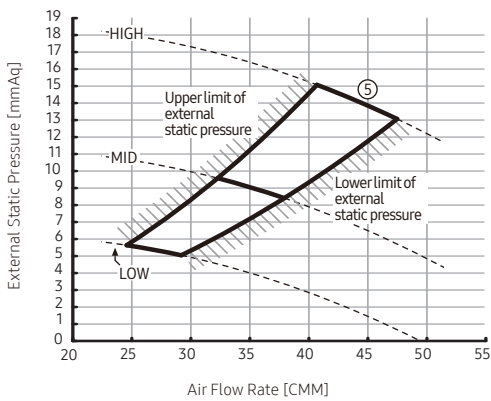

⑥	External Static Pressure(mmAq)	Option Code
	15<SP≤17	010054-1E5970-208080-331120

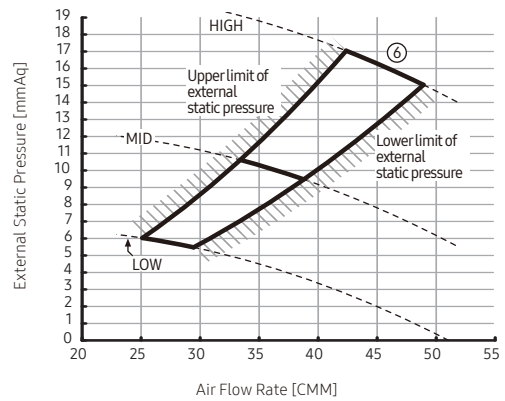

# 8. Fan Characteristics

## HSP Duct

### AM128DNHDKG/EU

⑦	External Static Pressure(mmAq)	Option Code
	17<SP≤19	010054-1E5992-208080-331120

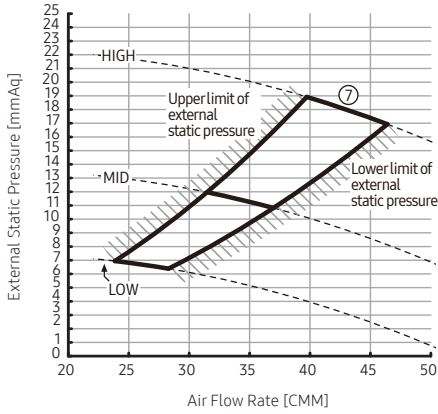

⑧	External Static Pressure(mmAq)	Option Code
	19<SP≤20	010054-1E59B1-208080-331120

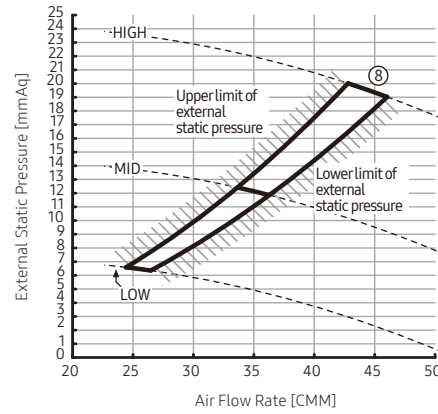

# 8. Fan Characteristics

## HSP Duct

### AM140DNHDKG/EU

①	External Static Pressure(mmAq)	Option Code
	3<SP≤6.2	010054-1E5489-208C8C-331120

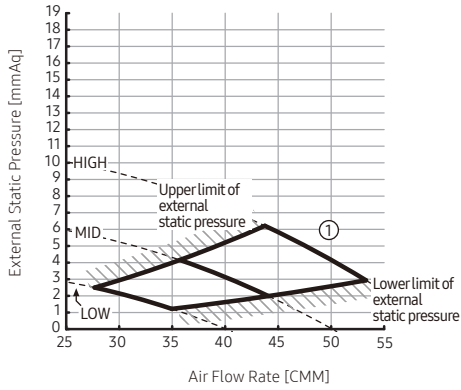

②	External Static Pressure(mmAq)	Option Code
	6.2<SP≤9	010054-1E54DA-208C8C-331120

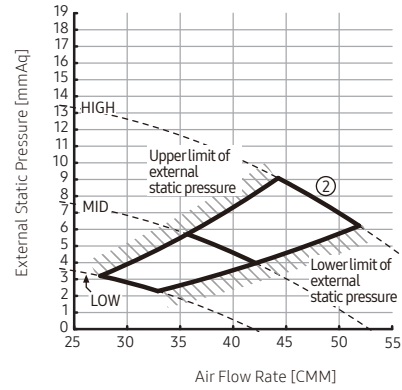

③	External Static Pressure(mmAq)	Option Code
	9<SP≤11	010054-1E580C-208C8C-331120

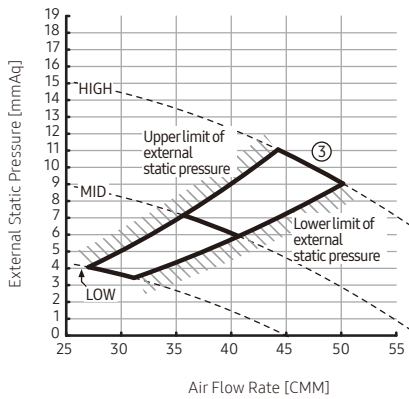

④	External Static Pressure(mmAq)	Option Code
	11<SP≤13	010054-1E583D-208C8C-331120

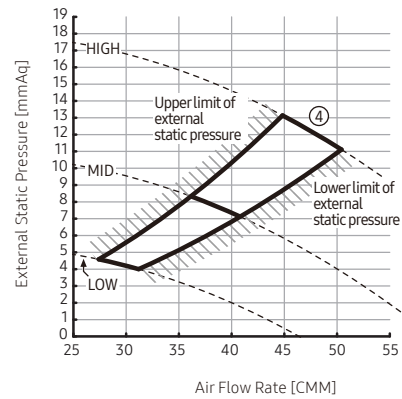

⑤	External Static Pressure(mmAq)	Option Code
	13<SP≤15	010054-1E586E-208C8C-331120

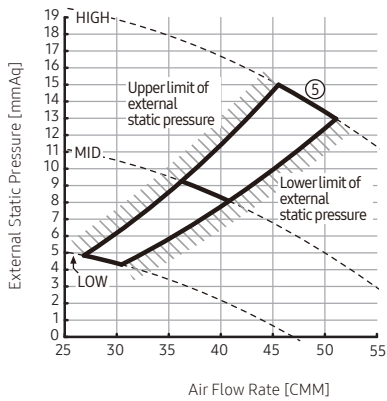

⑥	External Static Pressure(mmAq)	Option Code
	15<SP≤17	010054-1E5980-208C8C-331120

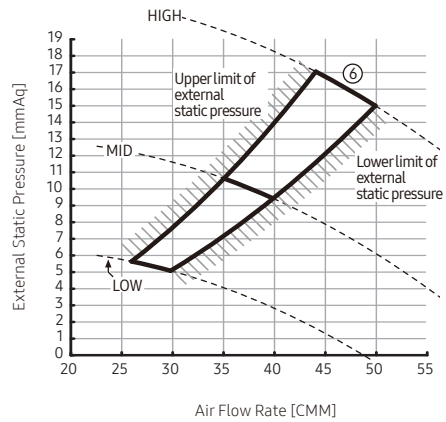

# 8. Fan Characteristics

## HSP Duct

### AM140DNHDKG/EU

⑦	External Static Pressure(mmAq)	Option Code
	17<SP≤19	010054-1E59B0-208C8C-331120

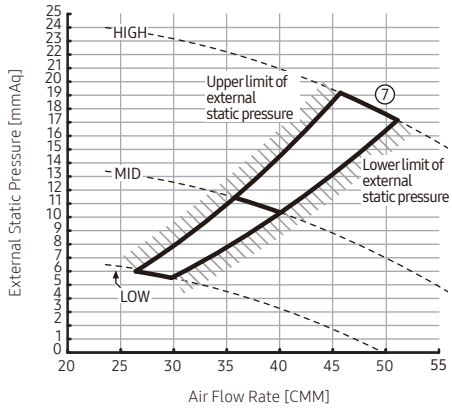

⑧	External Static Pressure(mmAq)	Option Code
	19<SP≤20	010054-1E59C1-208C8C-331120

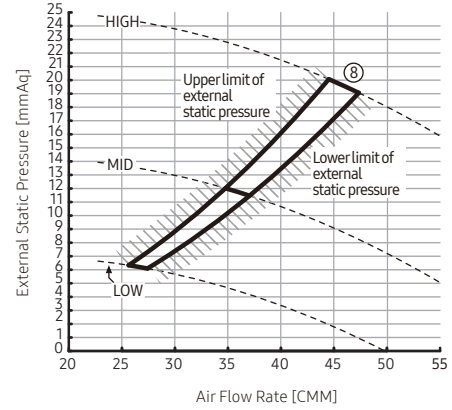

# 8. Fan Characteristics

## HSP Duct

### AM180HEHDKG/EU

①	External Static Pressure(mmAq)	Option Code
	5 < SP ≤ 7.5	12074-1C5080-20B4B4-331110

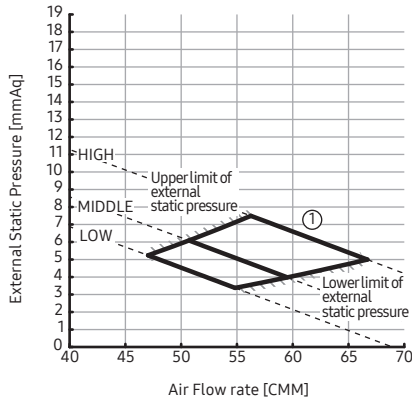

②	External Static Pressure(mmAq)	Option Code
	7.5 < SP ≤ 10	12074-1C50A1-20B4B4-33111

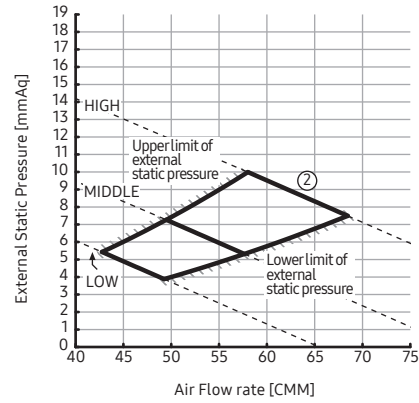

③	External Static Pressure(mmAq)	Option Code
	10 < SP ≤ 12.5	12074-1C50D3-20B4B4-331110

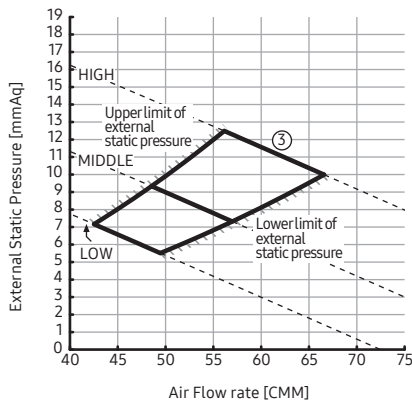

④	External Static Pressure(mmAq)	Option Code
	12.5 < SP ≤ 15	12074-1C50F5-20B4B4-331110

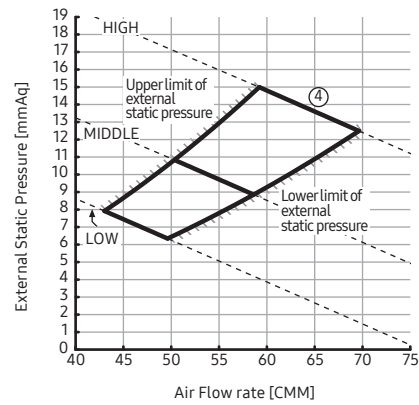

⑤	External Static Pressure(mmAq)	Option Code
	15 < SP ≤ 17.5	12074-1C5437-20B4B4-331110

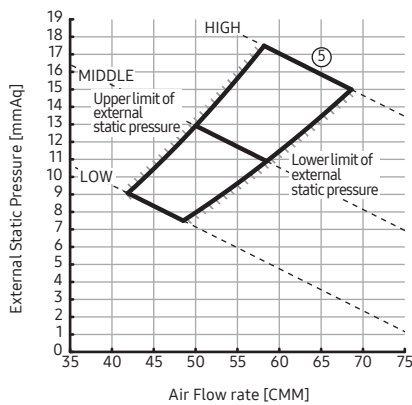

⑥	External Static Pressure(mmAq)	Option Code
	17.5 < SP ≤ 20	12074-1C5448-20B4B4-331110

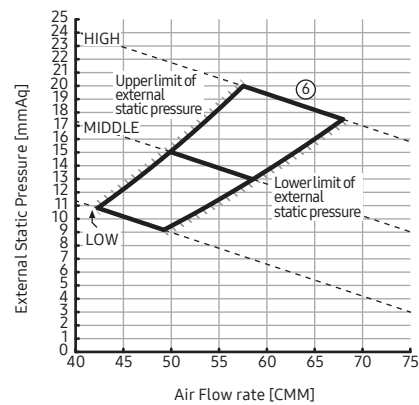

# 8. Fan Characteristics

## HSP Duct

### AM220HEHDKG/EU

①	External Static Pressure(mmAq)	Option Code
	5 < SP ≤ 7.5	12074-1C50C0-20E0E0-331110

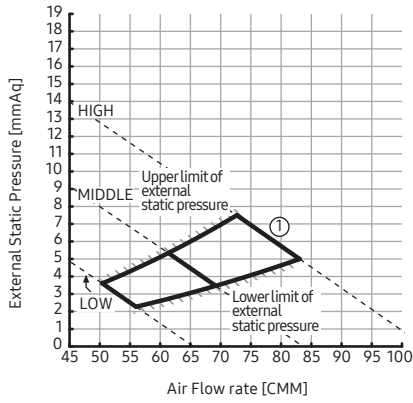

②	External Static Pressure(mmAq)	Option Code
	7.5 < SP ≤ 10	12074-1C50E3-20E0E0-331110

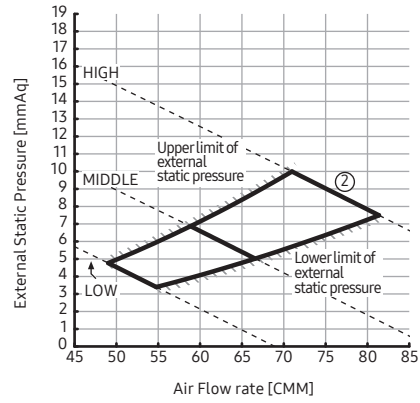

③	External Static Pressure(mmAq)	Option Code
	10 < SP ≤ 12.5	12074-1C50F5-20E0E0-331110

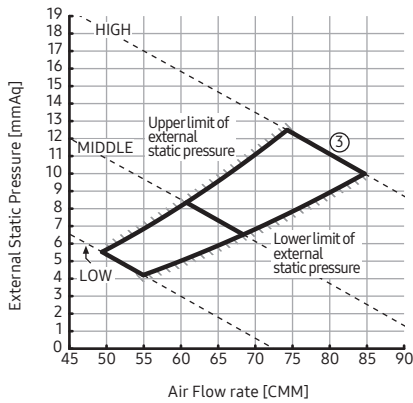

④	External Static Pressure(mmAq)	Option Code
	12.5 < SP ≤ 15	12074-1C5436-20E0E0-331110

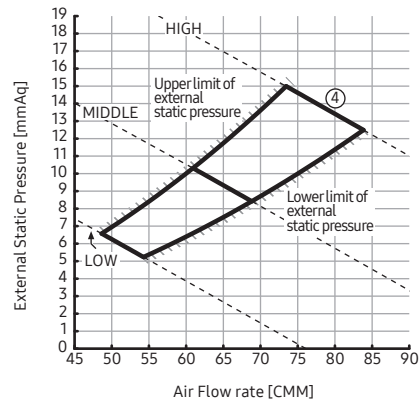

⑤	External Static Pressure(mmAq)	Option Code
	15 < SP ≤ 17.5	12074-1C5458-20E0E0-331110

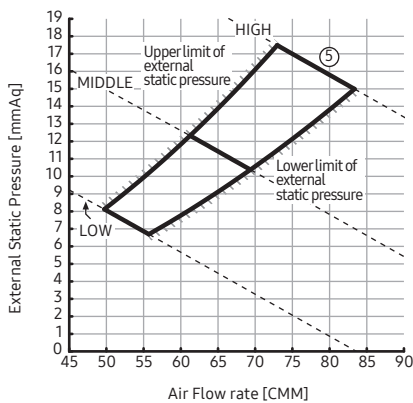

⑥	External Static Pressure(mmAq)	Option Code
	17.5 < SP ≤ 20	12074-1C548E-20E0E0-331110

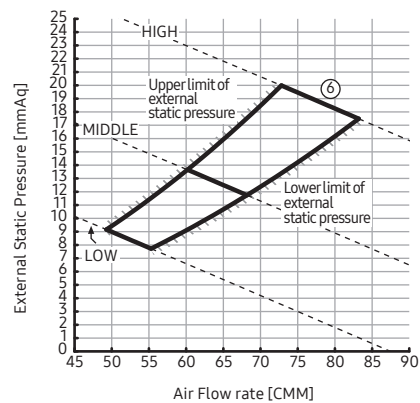

# 8. Fan Characteristics

---

HSP Duct

---

AM280HEHDKG/EU

TBD

---

# 9. Piping Diagram

## HSP Duct

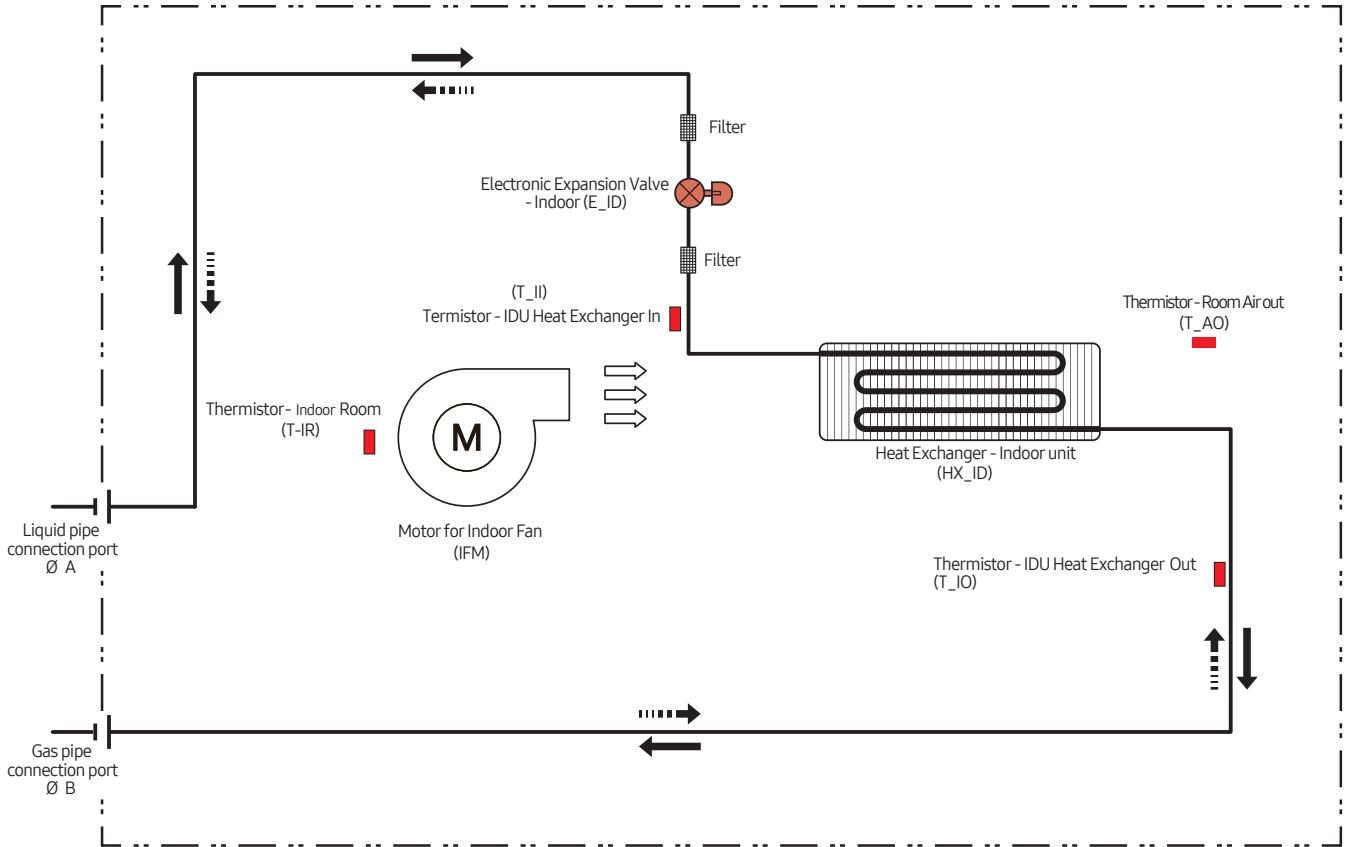

Refrigerant flow	
Cooling	Heating

# OAP Duct

---

<b>1. Specification</b>	<b>231</b>
<b>2. Summary Table</b>	<b>232</b>
<b>3. Capacity Table</b>	<b>233</b>
<b>4. Dimensional Drawing</b>	<b>239</b>
<b>5. Center of Gravity</b>	<b>241</b>
<b>6. Electrical Wiring Diagram</b>	<b>242</b>
<b>7. Sound Data</b>	<b>244</b>
<b>8. Fan Characteristics</b>	<b>246</b>
<b>9. Piping Diagram</b>	<b>247</b>



---

# Line-up

---

## OAP Duct

---

Capacity (kW)		
14.0	22.4	28.0
		

# 1. Specification

## OAP Duct

Model Name				AM140HEEDKG/EU	AM220HEEDKG/EU	AM280HEEDKG/EU
Power Supply			Φ, #, V, Hz	1,2,220-240,50/60	1,2,220-240,50/60	1,2,220-240,50/60
Performance	Capacity	Cooling	kW	14.0	22.4	28.0
			Btu/h	47,800	76,400	95,500
		Heating	kW	8.9	13.9	17.4
			Btu/h	30,400	47,400	59,400
Power	Power Input	Cooling	W	300.0	450.0	600.0
		Heating		300.0	450.0	600.0
	Current Input	Cooling	A	2.20	3.50	4.60
		Heating		2.20	3.50	4.60
	Current	MCA	A	TBD	TBD	TBD
		MFA		TBD	TBD	TBD
Heat exchanger	Type		-	Fin & Tube	Fin & Tube	Fin & Tube
	Material	Fin	-	Al	Al	Al
		Tube	-	Cu	Cu	Cu
	Fin Treatment		-	Green Hydrophile	Green Hydrophile	Green Hydrophile
Fan	Type	Type	-	Sirocco Fan	Sirocco Fan	Sirocco Fan
	Quantity		ea	2	2	2
	Air Flow Rate	H/M/L	CMM	18	28	35
			l/s	300	466.7	583.3
	External Pressure	Min/Std/Max	mmAq	15.30 / 20.40 / 25.50	18.40 / 23.40 / 29.60	20.40 / 25.50 / 30.60
			Pa	150.00 / 200.00 / 250.00	180.00 / 230.00 / 290.00	200.00 / 250.00 / 300.00
Fan Motor	Model		-	BLDC	BLDC	BLDC
	Output x n		W	183	630	630
Piping Connections	Liquid Pipe	Type	-	Flare connection	Flare connection	Flare connection
		Φ, mm (inch)	-	9.52 (3/8)	9.52 (3/8)	9.52 (3/8)
	Gas Pipe	Type	-	Flare connection	Flare connection	Flare connection
		Φ, mm (inch)	-	15.88 (5/8)	19.05 (3/4)	22.22 (7/8)
	Heat insulation		-	Both liquid & gas pipes	Both liquid & gas pipes	Both liquid & gas pipes
Drain Pipe		Φ,mm	VP25 (OD 32, ID 25)	VP25 (OD 32, ID 25)	VP25 (OD 32, ID 25)	
Wiring connections	Communication	Min.	mm <sup>2</sup>	0.75	0.75	0.75
		Remark	-	F1, F2	F1, F2	F1, F2
Refrigerant	Type		-	R32	R32	R32
	Electronic Expansion Valve		-	EEV INCLUDED	EEV INCLUDED	EEV INCLUDED
Sound Level	Sound Pressure Level	H/M/L	dB(A)	42	46	47
		Cooling		65	66	69
Dimensions	Net Weight		kg	49.0	81.5	81.5
	Shipping Weight		kg	56.0	90.5	90.5
	Net Dimensions (W×H×D)		mm	1,210 x 370 x 656	1,465 x 460 x 860	1,465 x 460 x 860
	Shipping Dimensions (W×H×D)		mm	1,456 x 440 x 778	1,612 x 519 x 984	1,612 x 519 x 984
Additional Accessories	Drain Pump		-	MDP-M075SGU2D	MDP-G075SP	MDP-G075SP
	Max. lifting Height / Displacement		mm / Liter/h	750 / 24	750 / 24	750 / 24
	Air Filter		-	-	-	-

### NOTE

- Specification may be subject to change without prior notice.
  - 1) Capacities are based on (Equivalent refrigerant piping 7.5m, Level differences 0m);
    - Cooling : Indoor temperature 27°C DB, 19°C WB / Outdoor temperature 35°C DB, 24°C WB
    - Heating : Indoor temperature 20°C DB, 15°C WB / Outdoor temperature 7°C DB, 6°C WB
  - 2) Sound level was acquired in an anechoic room. Thus actual noise level may be different depending on the installation conditions.
  - 3) These products contain R32 (GWP=675) which is fluorinated greenhouse gas.
  - 4) Select wire size based on the value of MCA

## 2. Summary Table

### OAP Duct

#### Performance Characteristics

Model Code	Fan Speed	Capacity (kW)			Airflow (CMM)	Sound Pressure (dBA)	Sound Power (dBA)	Static Pressure (Min/Std/Max) (mmAq)
		Cooling	Sensible	Heating				
AM140HEEDKG/EU	High	14.0	6.8	8.9	18	42	65	15.3 / 20.4 / 25.5
AM220HEEDKG/EU	High	22.4	10.8	13.9	28	46	66	18.4 / 23.4 / 29.6
AM280HEEDKG/EU	High	28.0	13.8	17.4	35	47	69	20.4 / 25.5 / 30.6

#### NOTE

- Sound data is based on cooling operation.

#### Electric Characteristics

Model Code	Power Supply (Φ, #, V, Hz)	Power Input (W)	Current Input (A)	MCA (A)	MFA (A)	FLA (A)
AM140HEEDKG/EU	1, 2, 220-240, 50/60	300	2.2	TBD	TBD	TBD
AM220HEEDKG/EU	1, 2, 220-240, 50/60	450	3.5	TBD	TBD	TBD
AM280HEEDKG/EU	1, 2, 220-240, 50/60	600	4.6	TBD	TBD	TBD

#### NOTE

- MCA : Minimum circuit amperes
- MFA : Maximum fuse amperes
- Select wire size based on the value of MCA

# 3. Capacity Table

## OAP Duct

AM140HEEDKG/EU

### Cooling

TC : Total Capacity, SHC : Sensible Heat Capacity

Discharge Temp. (°C)	Outdoor Air Temp. (°C, DB)	Outdoor Air Temp (WB)																	
		15 (°C, WB)		17 (°C, WB)		20 (°C, WB)		23 (°C, WB)		26 (°C, WB)		28 (°C, WB)		30 (°C, WB)		32 (°C, WB)		36 (°C, WB)	
		TC	SHC	TC	SHC	TC	SHC	TC	SHC	TC	SHC	TC	SHC	TC	SHC	TC	SHC	TC	SHC
		kW	kW	kW	kW	kW	kW	kW	kW	kW	kW	kW	kW	kW	kW	kW	kW	kW	
13	20	3.7	3.2	5.4	3.1														
	22	3.8	3.8	5.4	3.8	8.4	3.8												
	25	4.8	4.8	5.4	4.8	8.4	4.8	11.8	4.8										
	27	5.5	5.5	5.5	5.5	8.4	5.5	11.8	5.5										
	29	6.1	6.1	6.1	6.1	8.4	6.1	11.8	6.1	15.4	6.1								
	31	6.8	6.8	6.8	6.8	8.4	6.8	11.8	6.8	15.4	6.8	18.0	6.8						
	33			7.5	7.5	8.4	7.5	11.8	7.5	15.4	7.5	18.0	7.5	20.9	7.5				
	35			8.1	8.1	8.4	8.1	11.8	8.1	15.4	8.1	18.0	8.1	20.9	8.1	21.4	6.7		
	37					8.7	8.7	11.8	8.7	15.4	8.7	18.0	8.7	20.9	8.7	21.4	7.4		
	40					9.7	9.7	11.8	9.7	15.4	9.7	18.0	9.7	20.9	9.7	21.4	8.4	20.3	5.4
	45							11.8	11.2	15.4	11.2	18.0	11.2	20.9	11.2	21.4	10.1	20.3	7.1
	48									15.4	12.1	18.0	12.1	20.9	12.1	21.4	11.1	20.3	8.0
50									15.4	12.7	18.0	12.7	20.9	12.7	21.4	11.7	20.3	8.7	
55											18.0	14.1	20.9	14.1	21.4	13.3	20.3	10.2	
15	20	3.7	3.2	3.7	2.4														
	22	3.7	3.7	3.7	3.1	6.8	3.1												
	25	4.1	4.1	4.1	4.1	6.8	4.1	10.2	4.1										
	27	4.8	4.8	4.8	4.8	6.8	4.8	10.2	4.8										
	29	5.4	5.4	5.4	5.4	6.8	5.4	10.2	5.4	13.8	5.4								
	31	6.1	6.1	6.1	6.1	6.8	6.1	10.2	6.1	13.8	6.1	16.4	6.1						
	33			6.8	6.8	6.8	6.8	10.2	6.8	13.8	6.8	16.4	6.8	19.3	6.8				
	35			7.4	7.4	7.4	7.4	10.2	7.4	13.8	7.4	16.4	7.4	19.3	7.4	21.2	6.7		
	37					8.0	8.0	10.2	8.0	13.8	8.0	16.4	8.0	19.3	8.0	21.2	7.4		
	40					9.0	9.0	10.2	9.0	13.8	9.0	16.4	9.0	19.3	9.0	21.2	8.4	20.2	5.4
	45							10.5	10.5	13.8	10.5	16.4	10.5	19.3	10.5	21.2	10.1	20.2	7.0
	48									13.8	11.4	16.4	11.4	19.3	11.4	21.2	11.0	20.2	8.0
50									13.8	12.0	16.4	12.0	19.3	12.0	21.2	11.7	20.2	8.6	
55											16.4	13.4	19.3	13.4	21.2	13.2	20.2	10.2	
18	20	3.7	3.2	3.6	2.3														
	22	3.7	3.7	3.6	3.0	4.2	2.0												
	25	3.6	3.6	3.6	3.6	4.2	3.0	7.6	3.0										
	27	3.7	3.7	3.7	3.7	4.2	3.7	7.6	3.7										
	29	4.4	4.4	4.4	4.4	4.4	4.4	7.6	4.4	11.4	4.4								
	31	5.1	5.1	5.1	5.1	5.1	5.1	7.6	5.1	11.4	5.1	14.0	5.1						
	33			5.7	5.7	5.7	5.7	7.6	5.7	11.4	5.7	14.0	5.7	16.9	5.7				
	35			6.4	6.4	6.4	6.4	7.6	6.4	11.4	6.4	14.0	6.4	16.9	6.4	19.9	6.4		
	37					7.0	7.0	7.6	7.0	11.4	7.0	14.0	7.0	16.9	7.0	19.9	7.0		
	40					8.0	8.0	8.0	8.0	11.4	8.0	14.0	8.0	16.9	8.0	19.9	8.0	20.2	5.4
	45							9.6	9.6	11.4	9.6	14.0	9.6	16.9	9.6	19.9	9.6	20.2	7.1
	48									11.4	10.5	14.0	10.5	16.9	10.5	19.9	10.5	20.2	8.0
50									11.4	11.1	14.0	11.1	16.9	11.1	19.9	11.1	20.2	8.7	
55											14.0	12.5	16.9	12.5	19.9	12.5	20.2	10.2	
21	20																		
	22	3.7	3.7	3.5	3.0	3.5	1.8												
	25	3.6	3.6	3.6	3.6	3.5	2.8	4.9	2.0										
	27	3.6	3.6	3.6	3.6	3.5	3.5	4.9	2.7										
	29	3.5	3.5	3.5	3.5	3.5	3.5	4.9	3.4	8.6	3.4								
	31	4.1	4.1	4.1	4.1	4.1	4.1	4.9	4.1	8.6	4.1	11.4	4.1						
	33			4.7	4.7	4.7	4.7	4.9	4.7	8.6	4.7	11.4	4.7	14.3	4.7				
	35			5.4	5.4	5.4	5.4	5.4	5.4	8.6	5.4	11.4	5.4	14.3	5.4	17.4	5.4		
	37					6.1	6.1	6.1	6.1	8.6	6.1	11.4	6.1	14.3	6.1	17.4	6.1		
	40					7.0	7.0	7.0	7.0	8.6	7.0	11.4	7.0	14.3	7.0	17.4	7.0	20.2	5.5
	45							8.6	8.6	8.6	8.6	11.4	8.6	14.3	8.6	17.4	8.6	20.2	7.1
	48									9.5	9.5	11.4	9.5	14.3	9.5	17.4	9.5	20.2	8.1
50									10.1	10.1	11.4	10.1	14.3	10.1	17.4	10.1	20.2	8.7	
55											11.6	11.6	14.3	11.6	17.4	11.6	20.2	10.3	
25	20																		
	22																		
	25																		
	27	3.6	3.6	3.6	3.6	3.5	3.5	3.4	2.2										
	29	3.5	3.5	3.5	3.5	3.5	3.5	3.4	2.8	4.7	2.0								
	31	3.5	3.5	3.5	3.5	3.5	3.5	3.5	3.5	4.7	2.6	7.4	2.6						
	33			3.4	3.4	3.4	3.4	3.4	3.4	4.7	3.3	7.4	3.3	10.4	3.3				
	35			4.0	4.0	4.0	4.0	4.0	4.0	4.7	4.0	7.4	4.0	10.4	4.0	13.5	4.0		
	37					4.7	4.7	4.7	4.7	4.7	4.7	7.4	4.7	10.4	4.7	13.5	4.7		
	40					5.6	5.6	5.6	5.6	5.6	5.6	7.4	5.6	10.4	5.6	13.5	5.6	20.2	5.4
	45							7.2	7.2	7.2	7.2	7.2	7.2	10.4	7.2	13.5	7.2	20.2	7.1
	48									8.2	8.2	8.2	8.2	10.4	8.2	13.5	8.2	20.2	8.1
50									8.8	8.8	8.8	8.8	10.4	8.8	13.5	8.8	20.2	8.7	
55											10.3	10.3	10.4	10.3	13.5	10.3	20.2	10.3	

# 3. Capacity Table

## OAP Duct

AM140HEEDKG/EU

### Heating

TC : Total Capacity (kW)

Discharge Temp. (°C)	Outdoor Air Temperature (DB)						
	-7	-5	0	3	7	11	15
	TC	TC	TC	TC	TC	TC	TC
	kW	kW	kW	kW	kW	kW	kW
18	9.1	8.4	6.6	5.5	4.0	2.5	1.1
20	9.8	9.0	7.2	6.2	4.7	3.2	1.8
22	10.4	9.7	7.9	6.8	5.4	3.9	2.5
24	11.1	10.4	8.6	7.5	6.1	4.6	3.2
25	11.4	10.7	8.9	7.8	6.4	5.0	3.5
26	11.7	11.0	9.2	8.2	6.7	5.3	3.9
28	12.3	11.6	9.9	8.8	7.4	6.0	4.6
30	13.0	12.3	10.5	9.5	8.1	6.6	5.2

### NOTE

- The performance table shows the average value of each conditions.

# 3. Capacity Table

## OAP Duct

AM220HEEDKG/EU

### Cooling

TC : Total Capacity, SHC : Sensible Heat Capacity

Discharge Temp. (°C)	Outdoor Air Temp. (°C, DB)	Outdoor Air Temp (WB)																	
		15 (°C, WB)		17 (°C, WB)		20 (°C, WB)		23 (°C, WB)		26 (°C, WB)		28 (°C, WB)		30 (°C, WB)		32 (°C, WB)		36 (°C, WB)	
		TC kW	SHC kW	TC kW	SHC kW	TC kW	SHC kW	TC kW	SHC kW	TC kW	SHC kW	TC kW	SHC kW	TC kW	SHC kW	TC kW	SHC kW	TC kW	SHC kW
13	20	5.9	5.0	8.6	4.9														
	22	6.0	6.0	8.6	6.0	13.5	6.0												
	25	7.7	7.7	8.6	7.7	13.5	7.7	18.8	7.7										
	27	8.7	8.7	8.7	8.7	13.5	8.7	18.8	8.7										
	29	9.8	9.8	9.8	9.8	13.5	9.8	18.8	9.8	24.5	9.8								
	31	10.8	10.8	10.8	10.8	13.5	10.8	18.8	10.8	24.5	10.8	28.7	10.8						
	33					11.9	11.9	18.8	11.9	24.5	11.9	28.7	11.9	33.2	11.9				
	35					12.9	12.9	18.8	12.9	24.5	12.9	28.7	12.9	33.2	12.9	34.0	10.7		
	37							18.8	13.9	24.5	13.9	28.7	13.9	33.2	13.9	34.0	11.8		
	40							18.8	15.4	24.5	15.4	28.7	15.4	33.2	15.4	34.0	13.4	32.4	8.6
	45							18.8	17.8	24.5	17.8	28.7	17.8	33.2	17.8	34.0	16.1	32.4	11.2
	48									24.5	19.2	28.7	19.2	33.2	19.2	34.0	17.6	32.4	12.8
50									24.5	20.2	28.7	20.2	33.2	20.2	34.0	18.6	32.4	13.8	
55											28.7	22.4	33.2	22.4	34.0	21.1	32.4	16.3	
15	20	5.9	5.0	6.0	3.8														
	22	5.9	5.9	6.0	4.9	10.9	4.9												
	25	6.5	6.5	6.5	6.5	10.9	6.5	16.3	6.5										
	27	7.6	7.6	7.6	7.6	10.9	7.6	16.3	7.6										
	29	8.7	8.7	8.7	8.7	10.9	8.7	16.3	8.7	22.1	8.7								
	31	9.7	9.7	9.7	9.7	10.9	9.7	16.3	9.7	22.1	9.7	26.3	9.7						
	33					10.8	10.8	16.3	10.8	22.1	10.8	26.3	10.8	30.9	10.8				
	35					11.8	11.8	16.3	11.8	22.1	11.8	26.3	11.8	30.9	11.8	34.1	10.7		
	37							16.3	12.8	22.1	12.8	26.3	12.8	30.9	12.8	34.1	11.8		
	40							16.3	14.3	22.1	14.3	26.3	14.3	30.9	14.3	34.1	13.4	32.4	8.6
	45							16.8	16.8	22.1	16.8	26.3	16.8	30.9	16.8	34.1	16.1	32.4	11.2
	48									22.1	18.2	26.3	18.2	30.9	18.2	34.1	17.6	32.4	12.8
50									22.1	19.1	26.3	19.1	30.9	19.1	34.1	18.6	32.4	13.8	
55											26.3	21.4	30.9	21.4	34.1	21.1	32.4	16.3	
18	20	5.9	5.1	5.8	3.7														
	22	5.9	5.9	5.8	4.8	6.8	3.2												
	25	5.8	5.8	5.8	5.8	6.8	4.9	12.2	4.9										
	27	6.0	6.0	6.0	6.0	6.8	6.0	12.2	6.0										
	29	7.0	7.0	7.0	7.0	7.0	7.0	12.2	7.0	18.2	7.0								
	31	8.1	8.1	8.1	8.1	8.1	8.1	12.2	8.1	18.2	8.1	22.4	8.1						
	33					9.2	9.2	12.2	9.2	18.2	9.2	22.4	9.2	27.1	9.2				
	35					10.2	10.2	12.2	10.2	18.2	10.2	22.4	10.2	27.1	10.2	31.9	10.2		
	37							12.2	11.2	18.2	11.2	22.4	11.2	27.1	11.2	31.9	11.2		
	40							12.8	12.8	18.2	12.8	22.4	12.8	27.1	12.8	31.9	12.8	32.4	8.6
	45							15.2	15.2	18.2	15.2	22.4	15.2	27.1	15.2	31.9	15.2	32.4	11.3
	48									18.2	16.7	22.4	16.7	27.1	16.7	31.9	16.7	32.4	12.8
50									18.2	17.6	22.4	17.6	27.1	17.6	31.9	17.6	32.4	13.8	
55											22.4	19.9	27.1	19.9	31.9	19.9	32.4	16.3	
21	20																		
	22	5.9	5.9	5.7	4.8	5.6	2.8												
	25	5.8	5.8	5.8	5.8	5.6	4.4	7.8	3.2										
	27	5.7	5.7	5.7	5.7	5.6	5.5	7.8	4.3										
	29	5.6	5.6	5.6	5.6	5.7	5.7	7.8	5.4	13.9	5.4								
	31	6.5	6.5	6.5	6.5	6.5	6.5	7.8	6.5	13.9	6.5	18.3	6.5						
	33					7.5	7.5	7.8	7.5	13.9	7.5	18.3	7.5	22.9	7.5				
	35					8.6	8.6	8.6	8.6	13.9	8.6	18.3	8.6	22.9	8.6	27.9	8.6		
	37							9.6	9.6	13.9	9.6	18.3	9.6	22.9	9.6	27.9	9.6		
	40							11.2	11.2	13.9	11.2	18.3	11.2	22.9	11.2	27.9	11.2	32.5	8.7
	45							13.7	13.7	13.9	13.7	18.3	13.7	22.9	13.7	27.9	13.7	32.5	11.3
	48									15.2	15.2	18.3	15.2	22.9	15.2	27.9	15.2	32.5	12.9
50									16.1	16.1	18.3	16.1	22.9	16.1	27.9	16.1	32.5	13.9	
55											18.5	18.5	22.9	18.5	27.9	18.5	32.5	16.4	
25	20																		
	22																		
	25																		
	27	5.7	5.7	5.7	5.7	5.6	5.6	5.5	3.5										
	29	5.7	5.7	5.7	5.7	5.7	5.7	5.5	4.5	7.6	3.1								
	31	5.6	5.6	5.6	5.6	5.6	5.6	5.6	5.6	7.6	4.2	11.9	4.2						
	33					5.5	5.5	5.5	5.5	7.6	5.3	11.9	5.3	16.8	5.3				
	35					6.4	6.4	6.4	6.4	7.6	6.4	11.9	6.4	16.8	6.4	21.8	6.4		
	37							7.5	7.5	7.5	7.5	11.9	7.5	16.8	7.5	21.8	7.5		
	40							9.0	9.0	9.0	9.0	11.9	9.0	16.8	9.0	21.8	9.0	32.5	8.7
	45							11.6	11.6	11.6	11.6	11.6	11.6	16.8	11.6	21.8	11.6	32.5	11.4
	48									13.1	13.1	13.1	13.1	16.8	13.1	21.8	13.1	32.5	12.9
50									14.1	14.1	14.1	14.1	16.8	14.1	21.8	14.1	32.5	13.9	
55											16.5	16.5	16.8	16.5	21.8	16.5	32.5	16.5	

# 3. Capacity Table

## OAP Duct

AM220HEEDKG/EU

### Heating

TC : Total Capacity (kW)

Discharge Temp. (°C)	Outdoor Air Temperature (DB)						
	-7	-5	0	3	7	11	15
	TC	TC	TC	TC	TC	TC	TC
	kW	kW	kW	kW	kW	kW	kW
18	14.2	13.1	10.2	8.5	6.2	4.0	1.7
20	15.3	14.1	11.3	9.6	7.3	5.1	2.8
22	16.3	15.2	12.4	10.7	8.4	6.2	3.9
24	17.3	16.2	13.4	11.7	9.5	7.2	5.0
25	17.8	16.7	13.9	12.2	10.0	7.8	5.5
26	18.3	17.2	14.4	12.7	10.5	8.3	6.1
28	19.3	18.2	15.4	13.8	11.6	9.3	7.1
30	20.2	19.1	16.4	14.8	12.6	10.4	8.2

### NOTE

- The performance table shows the average value of each conditions.

# 3. Capacity Table

## OAP Duct

AM280HEEDKG/EU

### Cooling

TC : Total Capacity, SHC : Sensible Heat Capacity

Discharge Temp. (°C)	Outdoor Air Temp. (°C, DB)	Outdoor Air Temp (WB)																	
		15 (°C, WB)		17 (°C, WB)		20 (°C, WB)		23 (°C, WB)		26 (°C, WB)		28 (°C, WB)		30 (°C, WB)		32 (°C, WB)		36 (°C, WB)	
		TC kW	SHC kW	TC kW	SHC kW	TC kW	SHC kW	TC kW	SHC kW	TC kW	SHC kW	TC kW	SHC kW	TC kW	SHC kW	TC kW	SHC kW	TC kW	SHC kW
13	20	7.3	6.3	10.7	6.1														
	22	7.5	7.5	10.7	7.5	16.9	7.5												
	25	9.6	9.6	10.7	9.6	16.9	9.6	23.5	9.6										
	27	10.9	10.9	10.9	10.9	16.9	10.9	23.5	10.9										
	29	12.2	12.2	12.2	12.2	16.9	12.2	23.5	12.2	30.7	12.2								
	31	13.5	13.5	13.5	13.5	16.9	13.5	23.5	13.5	30.7	13.5	35.9	13.5						
	33			14.8	14.8	16.9	14.8	23.5	14.8	30.7	14.8	35.9	14.8	41.6	14.8				
	35			16.1	16.1	16.9	16.1	23.5	16.1	30.7	16.1	35.9	16.1	41.6	16.1	42.6	13.4		
	37					17.4	17.4	23.5	17.4	30.7	17.4	35.9	17.4	41.6	17.4	42.6	14.7		
	40					19.2	19.2	23.5	19.2	30.7	19.2	35.9	19.2	41.6	19.2	42.6	16.8	40.5	10.8
	45							23.5	22.3	30.7	22.3	35.9	22.3	41.6	22.3	42.6	20.0	40.5	14.0
	48									30.7	24.0	35.9	24.0	41.6	24.0	42.6	22.0	40.5	15.9
	50									30.7	25.2	35.9	25.2	41.6	25.2	42.6	23.3	40.5	17.2
55											35.9	28.0	41.6	28.0	42.6	26.4	40.5	20.3	
15	20	7.4	6.3	7.5	4.7														
	22	7.3	7.3	7.5	6.1	13.7	6.1												
	25	8.1	8.1	8.1	8.1	13.7	8.1	20.4	8.1										
	27	9.5	9.5	9.5	9.5	13.7	9.5	20.4	9.5										
	29	10.8	10.8	10.8	10.8	13.7	10.8	20.4	10.8	27.7	10.8								
	31	12.1	12.1	12.1	12.1	13.7	12.1	20.4	12.1	27.7	12.1	32.9	12.1						
	33			13.4	13.4	13.7	13.4	20.4	13.4	27.7	13.4	32.9	13.4	38.6	13.4				
	35			14.7	14.7	14.7	14.7	20.4	14.7	27.7	14.7	32.9	14.7	38.6	14.7	42.6	13.3		
	37					16.0	16.0	20.4	16.0	27.7	16.0	32.9	16.0	38.6	16.0	42.6	14.7		
	40					17.8	17.8	20.4	17.8	27.7	17.8	32.9	17.8	38.6	17.8	42.6	16.7	40.5	10.7
	45							20.9	20.9	27.7	20.9	32.9	20.9	38.6	20.9	42.6	20.0	40.5	14.0
	48									27.7	22.7	32.9	22.7	38.6	22.7	42.6	21.9	40.5	15.9
	50									27.7	23.8	32.9	23.8	38.6	23.8	42.6	23.2	40.5	17.2
55											32.9	26.7	38.6	26.7	42.6	26.3	40.5	20.3	
18	20	7.3	6.3	7.2	4.6														
	22	7.3	7.3	7.2	5.9	8.5	4.0												
	25	7.2	7.2	7.2	7.2	8.5	6.0	15.3	6.0										
	27	7.4	7.4	7.4	7.4	8.5	7.4	15.3	7.4										
	29	8.8	8.8	8.8	8.8	8.8	8.8	15.3	8.8	22.8	8.8								
	31	10.1	10.1	10.1	10.1	10.1	10.1	15.3	10.1	22.8	10.1	28.0	10.1						
	33			11.4	11.4	11.4	11.4	15.3	11.4	22.8	11.4	28.0	11.4	33.8	11.4				
	35			12.7	12.7	12.7	12.7	15.3	12.7	22.8	12.7	28.0	12.7	33.8	12.7	39.9	12.7		
	37					14.0	14.0	15.3	14.0	22.8	14.0	28.0	14.0	33.8	14.0	39.9	14.0		
	40					15.9	15.9	15.9	15.9	22.8	15.9	28.0	15.9	33.8	15.9	39.9	15.9	40.5	10.8
	45							19.0	19.0	22.8	19.0	28.0	19.0	33.8	19.0	39.9	19.0	40.5	14.0
	48									22.8	20.8	28.0	20.8	33.8	20.8	39.9	20.8	40.5	16.0
	50									22.8	21.9	28.0	21.9	33.8	21.9	39.9	21.9	40.5	17.2
55											28.0	24.8	33.8	24.8	39.9	24.8	40.5	20.3	
21	20																		
	22	7.3	7.3	7.1	5.9	7.0	3.5												
	25	7.1	7.1	7.1	7.1	7.0	5.4	9.7	3.9										
	27	7.1	7.1	7.1	7.1	7.0	6.8	9.7	5.3										
	29	7.0	7.0	7.0	7.0	7.0	7.0	9.7	6.6	17.3	6.6								
	31	8.0	8.0	8.0	8.0	8.0	8.0	9.7	8.0	17.3	8.0	22.8	8.0						
	33			9.3	9.3	9.3	9.3	9.7	9.3	17.3	9.3	22.8	9.3	28.5	9.3				
	35			10.6	10.6	10.6	10.6	10.6	10.6	17.3	10.6	22.8	10.6	28.5	10.6	34.7	10.6		
	37					11.9	11.9	11.9	11.9	17.3	11.9	22.8	11.9	28.5	11.9	34.7	11.9		
	40					13.8	13.8	13.8	13.8	17.3	13.8	22.8	13.8	28.5	13.8	34.7	13.8	40.4	10.7
	45							16.9	16.9	17.3	16.9	22.8	16.9	28.5	16.9	34.7	16.9	40.4	14.0
	48									18.7	18.7	22.8	18.7	28.5	18.7	34.7	18.7	40.4	15.9
	50									19.9	19.9	22.8	19.9	28.5	19.9	34.7	19.9	40.4	17.1
55											22.8	22.8	28.5	22.8	34.7	22.8	40.4	20.2	
25	20																		
	22																		
	25																		
	27	7.1	7.1	7.1	7.1	6.9	6.9	6.9	4.3										
	29	7.0	7.0	7.0	7.0	7.0	7.0	6.9	5.6	9.4	3.9								
	31	6.9	6.9	6.9	6.9	6.9	6.9	6.9	6.9	9.4	5.2	14.8	5.2						
	33			6.7	6.7	6.8	6.8	6.8	6.8	9.4	6.6	14.8	6.6	20.9	6.6				
	35			7.9	7.9	7.9	7.9	7.9	7.9	9.4	7.9	14.8	7.9	20.9	7.9	27.1	7.9		
	37					9.2	9.2	9.2	9.2	9.2	9.2	14.8	9.2	20.9	9.2	27.1	9.2		
	40					11.2	11.2	11.2	11.2	11.2	11.2	14.8	11.2	20.9	11.2	27.1	11.2	40.4	10.7
	45							14.3	14.3	14.3	14.3	14.3	14.3	20.9	14.3	27.1	14.3	40.4	14.0
	48									16.2	16.2	16.2	16.2	20.9	16.2	27.1	16.2	40.4	15.9
	50									17.4	17.4	17.4	17.4	20.9	17.4	27.1	17.4	40.4	17.2
55											20.3	20.3	20.9	20.3	27.1	20.3	40.4	20.3	

# 3. Capacity Table

---

## OAP Duct

---

AM280HEEDKG/EU

### Heating

TC : Total Capacity (kW)

Discharge Temp. (°C)	Outdoor Air Temperature (DB)						
	-7	-5	0	3	7	11	15
	TC	TC	TC	TC	TC	TC	TC
	kW	kW	kW	kW	kW	kW	kW
18	17.8	16.4	12.8	10.7	7.8	5.0	2.1
20	19.1	17.7	14.2	12.0	9.2	6.3	3.5
22	20.4	19.0	15.5	13.4	10.5	7.7	4.9
24	21.6	20.2	16.8	14.7	11.9	9.1	6.2
25	22.3	20.9	17.4	15.3	12.5	9.7	6.9
26	22.9	21.5	18.0	16.0	13.2	10.4	7.6
28	24.1	22.7	19.3	17.2	14.5	11.7	8.9
30	25.3	24.0	20.5	18.5	15.7	13.0	10.2

### NOTE

- The performance table shows the average value of each conditions.
-

# 4. Dimensional Drawing

## OAP Duct

### AM140HEEDKG/EU

Units : mm [inches]

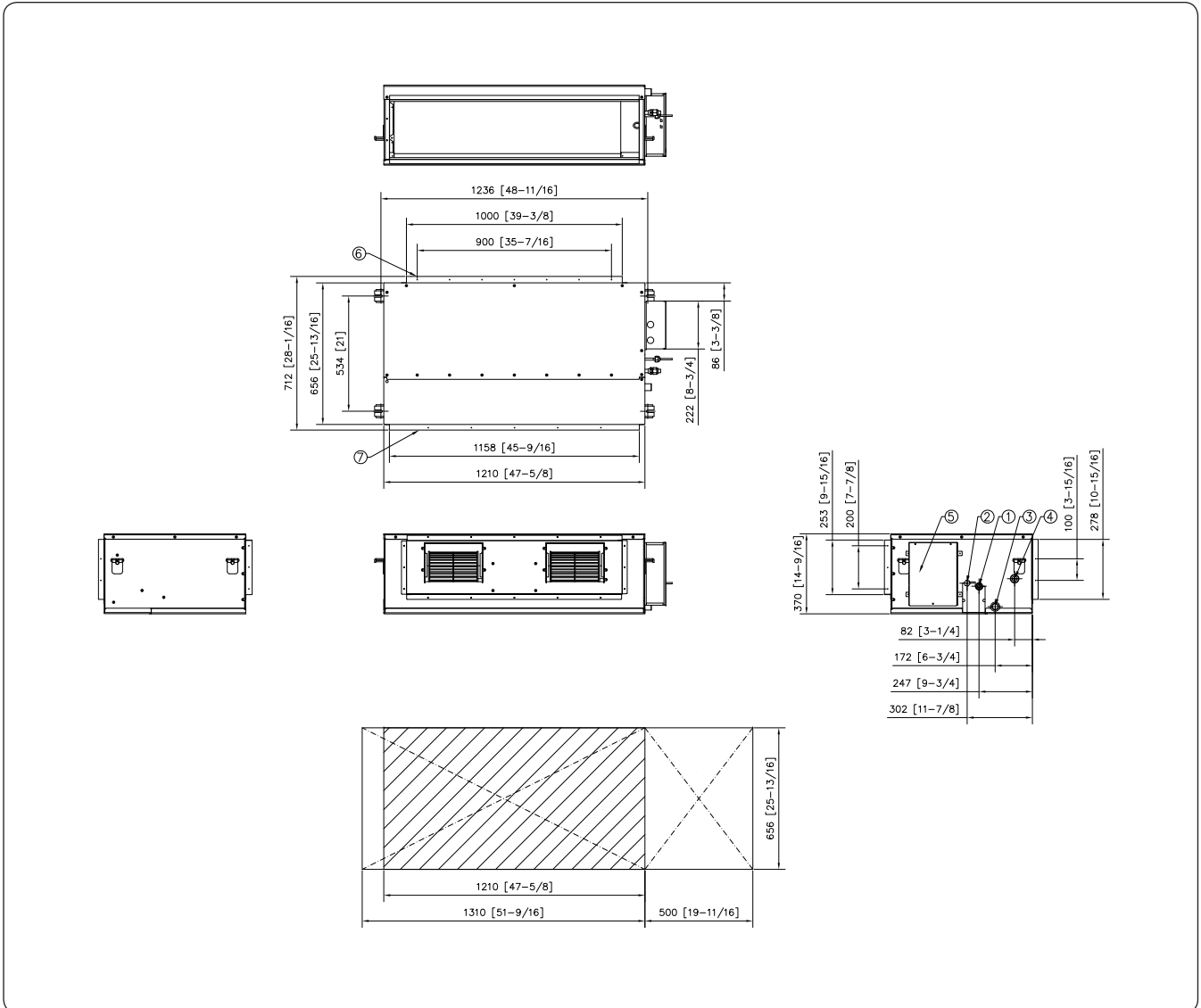

No.	Name	Description
①	Gas pipe connection	Φ15.88 (5/8)
②	Liquid pipe connection	Ø9.52 (3/8)
③	Drain pipe connection (Without drain pump)	VP25 (OD 32, ID 25)
④	Drain pipe connection (With drain pump)	-
⑤	Power & Communication Conduits	-
⑥	Air discharge grille flange	-
⑦	Return air side	-

# 4. Dimensional Drawing

## OAP Duct

### AM220HEEDKG/EU, AM280HEEDKG/EU

Units : mm [inches]

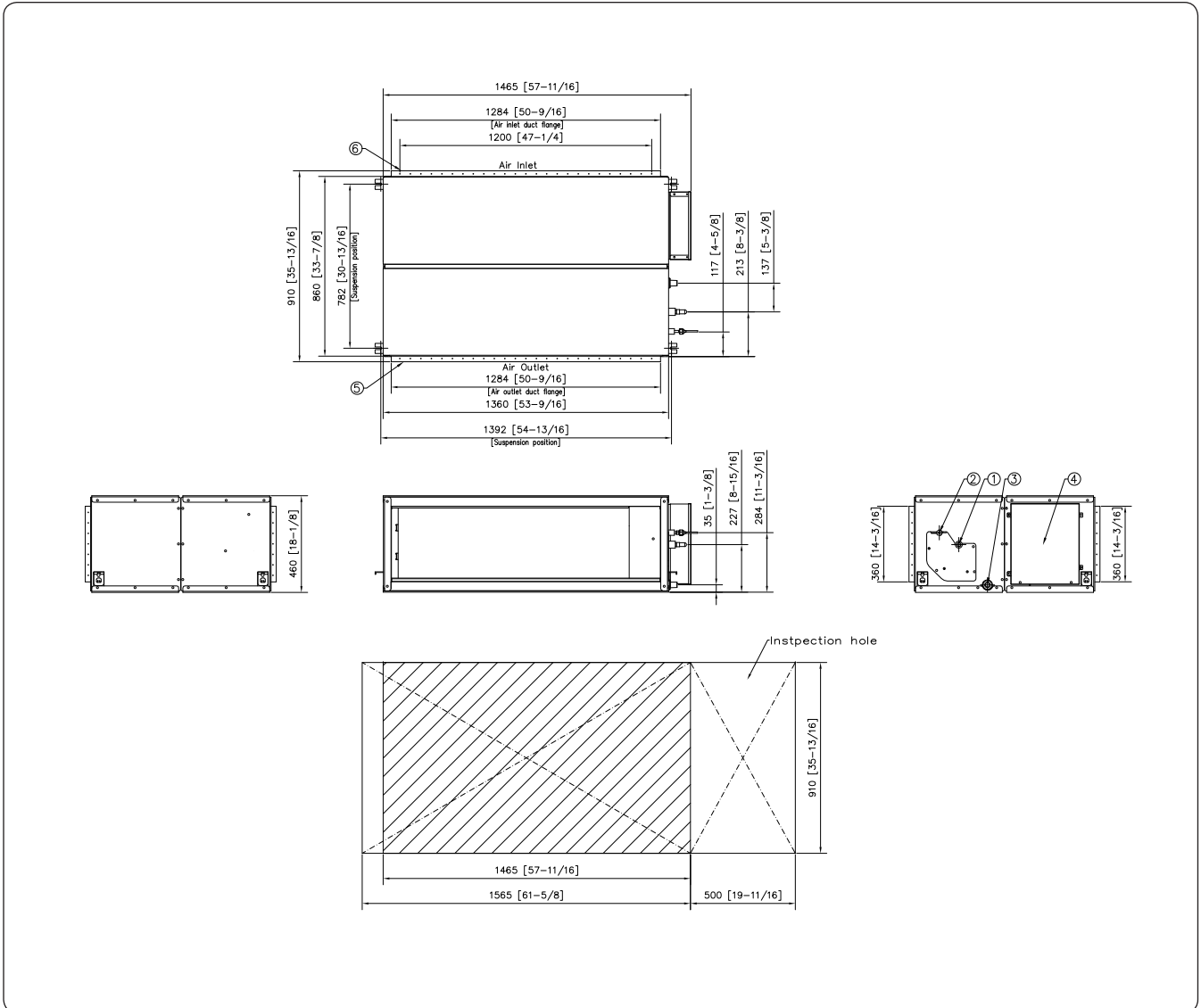

No.	Name	Description	
		AM220HEEDKG/EU	AM280HEEDKG/EU
①	Gas pipe connection	Φ19.05 (3/4)	Φ22.22 (7/8)
②	Liquid pipe connection	Ø9.52 (3/8)	
③	Drain pipe connection	VP25 (OD 32, ID 25)	
④	Power & Communication Conduits	-	
⑤	Air discharge grille flange	-	
⑥	Return air side	-	

# 5. Center of Gravity

## OAP Duct

### AM140HEEDKG/EU

Units : mm

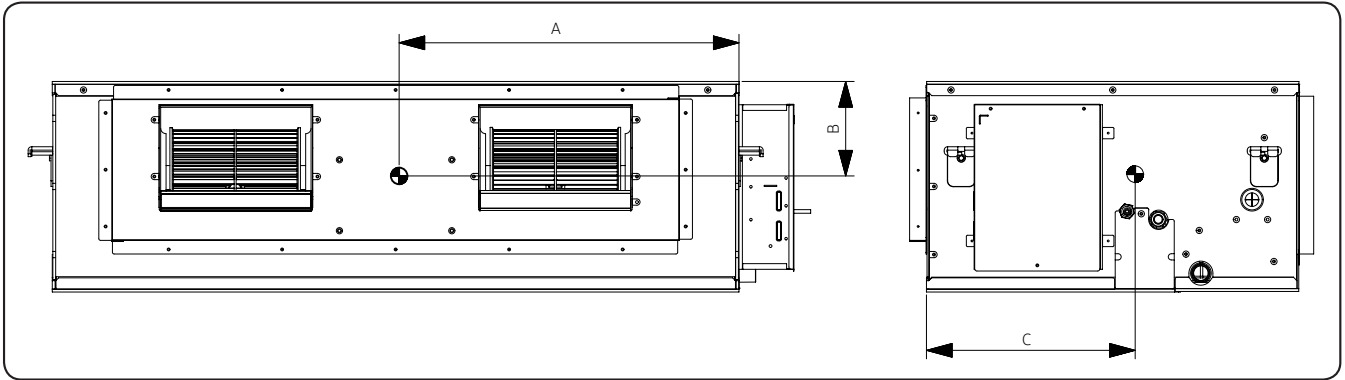

Model	A	B	C
AM140HEEDKG/EU	590	180	320

### AM220HEEDKG/EU, AM280HEEDKG/EU

Units : mm

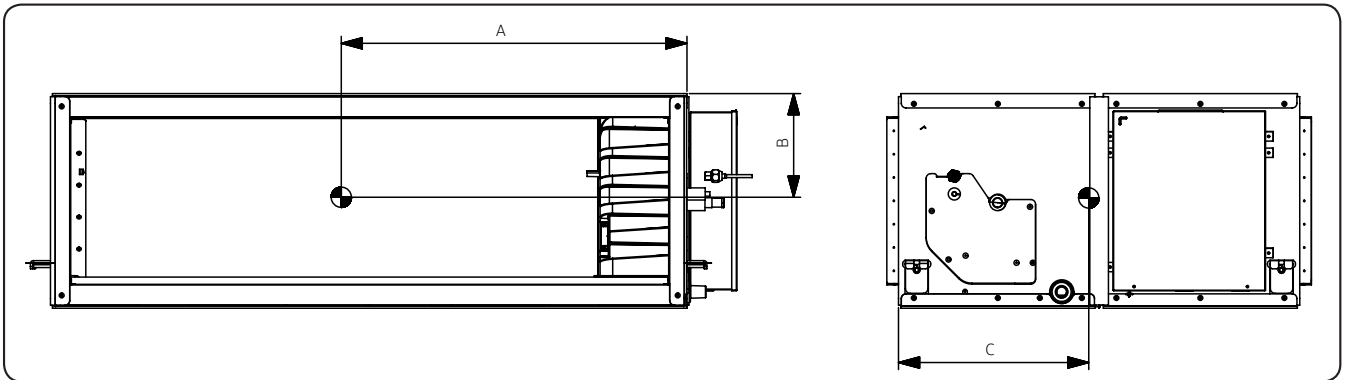

Model	A	B	C
AM220HEEDKG/EU	670	220	420
AM280HEEDKG/EU	670	220	420

# 6. Electrical Wiring Diagram

## OAP Duct

AM140HEEDKG/EU

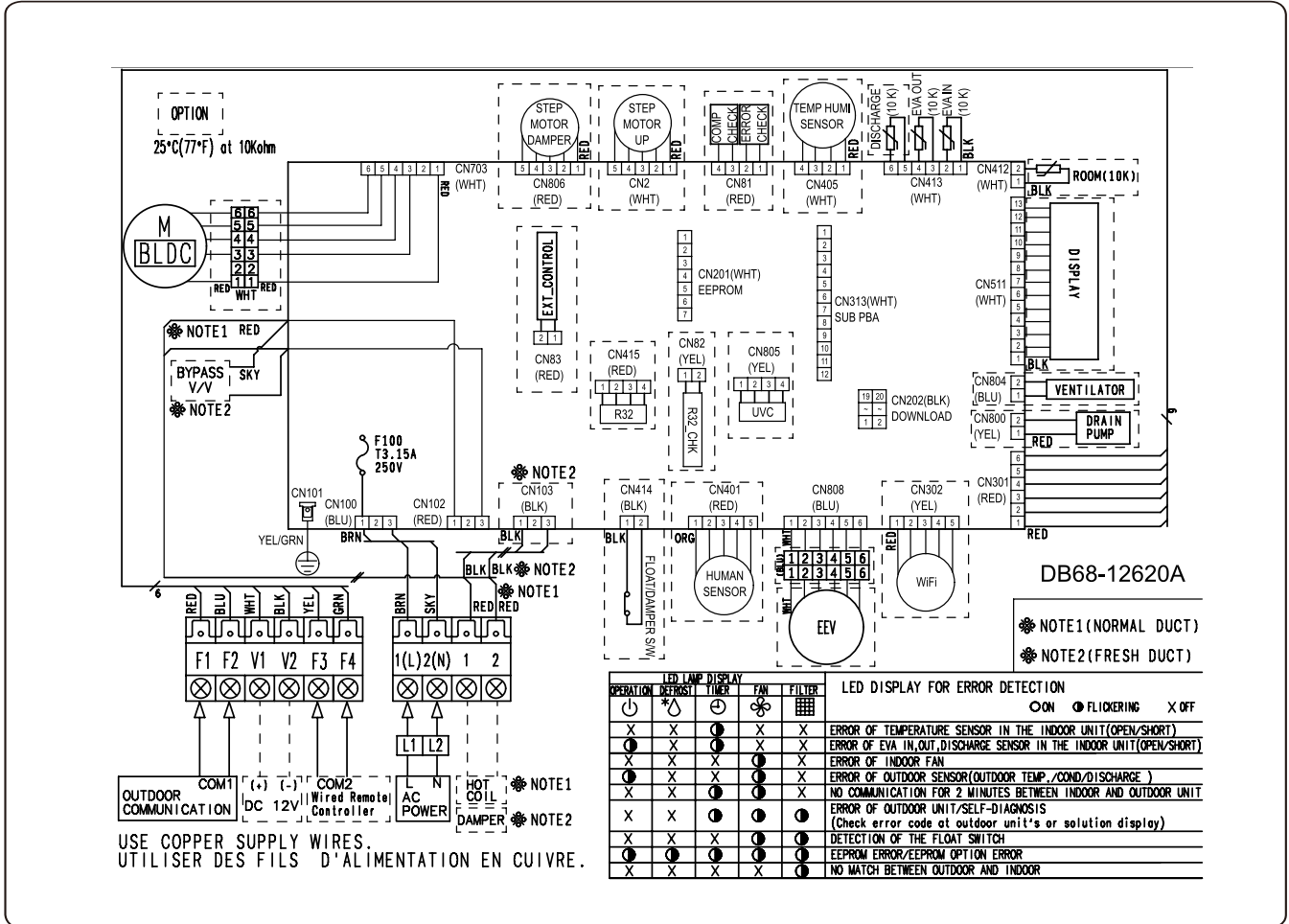

F100	Fuse	ROOM(10K)	Thermistor - Indoor Room
EEV	Electronic Expansion Valve	EVA IN (10K)	Thermistor - IDU heat exchanger In
M-BLDC	Motor for Indoor Fan	EVA OUT (10K)	Thermistor - IDU heat exchanger Out
ERROR CHECK	Contact output port for error check	EEPROM	EEPROM SUB PBA
COMP CHECK	Contact output port for compressor operation check	SUB PBA	SUB PBA for wired remote control communication
EXTERNAL CTRL	Input port for external contact control	DAMPER	Contact output port for Damper control
VENTILATOR	Contact output port for Ventilator control	HOT COIL	Contact output port for Hot coil control

### NOTE

- This wiring diagram applies only to the Indoor unit.
- Symbols show as follow : BLK: black, RED: red, BLU: blue, WHT: white, YEL: yellow, GRN: green
- For connection wiring indoor-outdoor transmission F1-F2, indoor-wired remote controller transmission F3-F4.
- ⊕ Protective earth(screw), □□□□ : connector,  $\frac{N}{x}$  : The wire quantity

# 6. Electrical Wiring Diagram

## OAP Duct

AM220HEEDKG/EU, AM280HEEDKG/EU

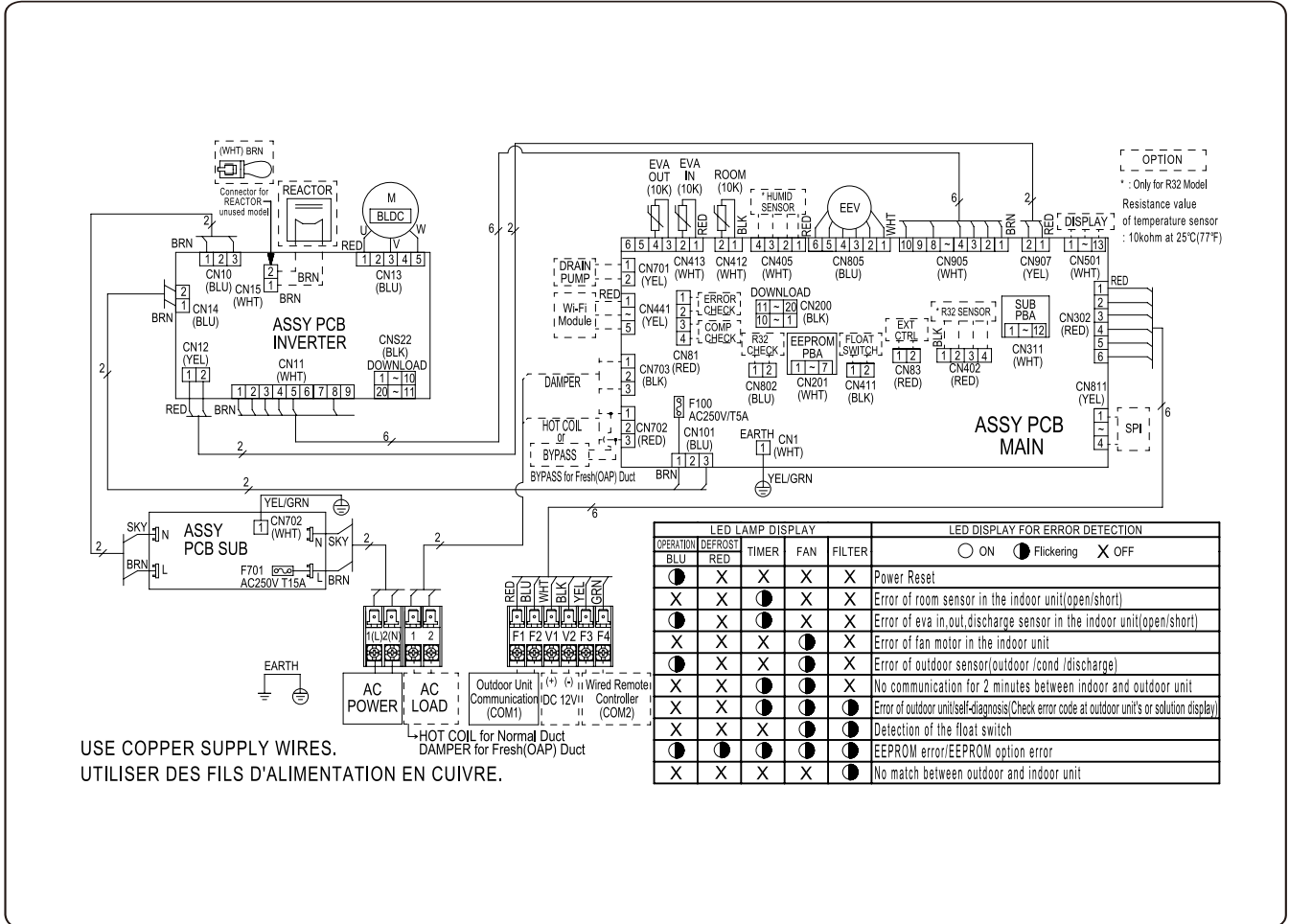

F100	Fuse	ROOM(10K)	Thermistor - Indoor Room
EEV	Electronic Expansion Valve	EVA IN (10K)	Thermistor - IDU heat exchanger In
M-BLDC	Motor for Indoor Fan	EVA OUT (10K)	Thermistor - IDU heat exchanger Out
ERROR CHECK	Contact output port for error check	EEPROM	EEPROM SUB PBA
COMP CHECK	Contact output port for compressor operation check	SUB PBA	SUB PBA for wired remote control communication
EXTERNAL CTRL	Input port for external contact control	DAMPER	Contact output port for Damper control
VENTILATOR	Contact output port for Ventilator control	HOT COIL	Contact output port for Hot coil control
BYPASS	Contact output port for Bypass control		

### NOTE

- This wiring diagram applies only to the Indoor unit.
- Symbols show as follow : BLK: black, RED: red, BLU: blue, WHT: white, YEL: yellow, GRN: green
- For connection wiring indoor-outdoor transmission F1-F2, indoor-wired remote controller transmission F3-F4.
- ⊕ Protective earth(screw), □ : connector,  $\frac{N}{\times}$  : The wire quantity

# 7. Sound Data

## OAP Duct

### Sound pressure level

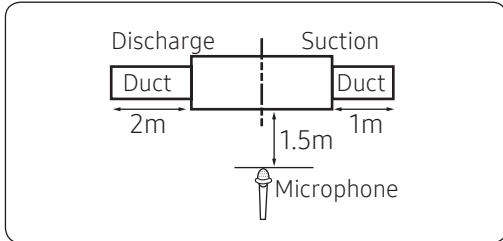

Unit: dB(A)

MODEL	High	Mid	Low
AM140HEEDKG/EU			
AM220HEEDKG/EU			
AM280HEEDKG/EU			

- NR Curve

1) AM140HEEDKG/EU

2) AM220HEEDKG/EU

# TBD

3) AM280HEEDKG/EU

### NOTE

- Specifications may be subject to change without prior notice.
  - Sound pressure level is obtained in an anechoic room.
  - Sound pressure level is a relative value, depending on the distance and acoustic environment.
  - Sound pressure level may differ depending on operation condition.
  - dBA = A weighted sound pressure level
  - Reference acoustic pressure 0 dB = 20μPa

# 7. Sound Data

---

## OAP Duct

---

### Sound Power level

 **NOTE**

- Specifications may be subject to change without prior notice
  - Sound power level is an absolute value that a sound source generates.
  - dBA = A-weighted sound power level.
  - Reference power : 1pW.
  - Measured according to ISO 3741.

Unit: dB(A)

Model	Power
AM140HEEDKG/EU	65
AM220HEEDKG/EU	66
AM280HEEDKG/EU	69

- NR Curve

1) AM140HEEDKG/EU

2) AM220HEEDKG/EU

TBD

3) AM280HEEDKG/EU

## 8. Fan Characteristics

---

OAP Duct

---

1) AM140HEEDKG/EU

2) AM220HEEDKG/EU

3) AM280HEEDKG/EU

TBD

---

# 9. Piping Diagram

## OAP Duct

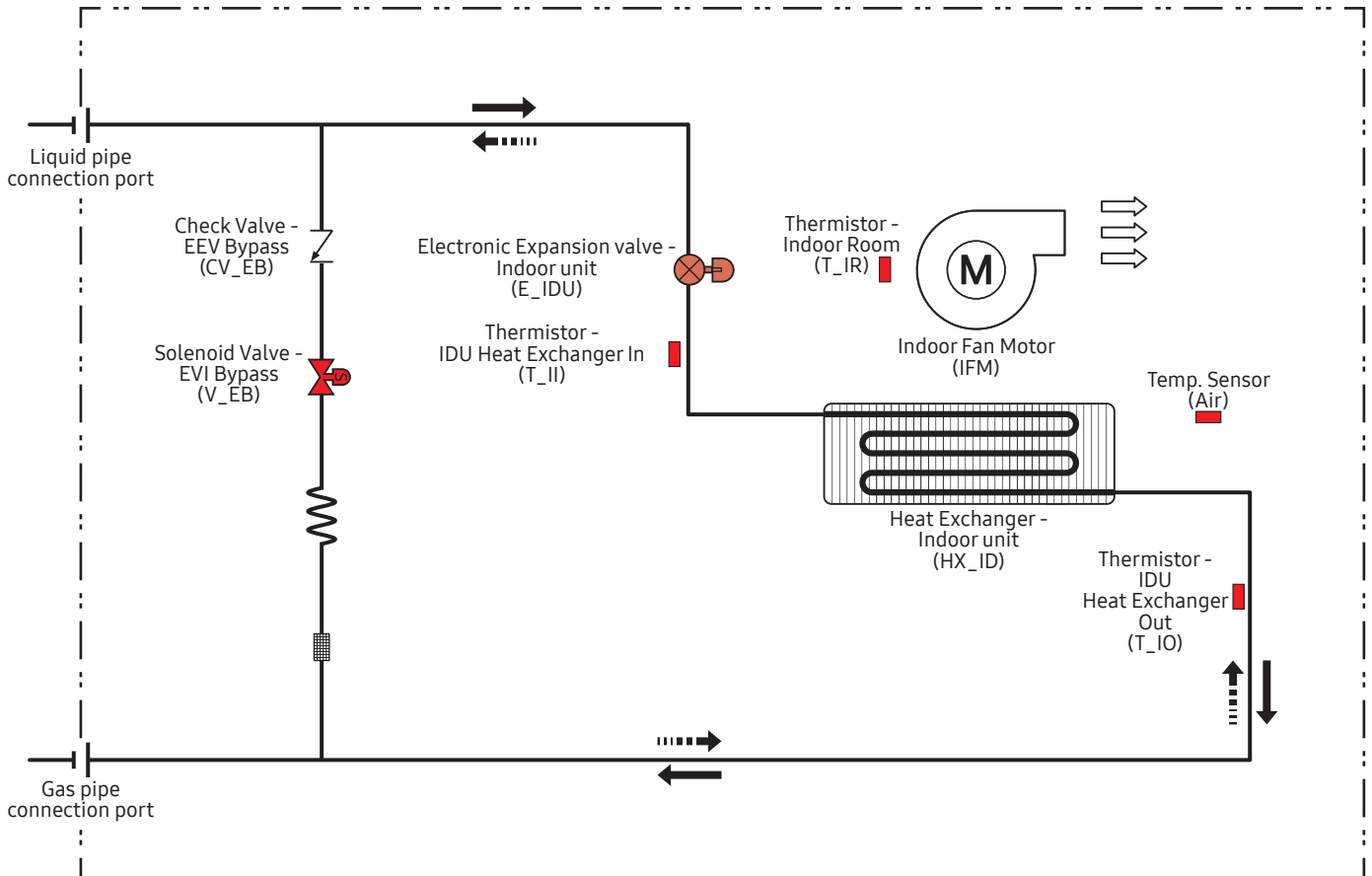

Refrigerant flow	
Cooling	Heating
→	- - - - - →

# Wall mounted



---

1. Specification	250
2. Summary Table	254
3. Capacity Table	255
4. Dimensional Drawing	256
5. Center of Gravity	259
6. Electrical Wiring Diagram	260
7. Sound Data	262
8. Temperature and air flow distribution	268
9. Piping Diagram	277

---

# Line-up

## Wall mounted

Capacity (kW)								
1.5	2.2	2.8	3.6	4.5	5.6	7.1	8.2	9.3
								

# 1. Specification

## Wall mounted

Model Name				AM015DNVDKG/EU	AM022DNVDKG/EU	AM028DNVDKG/EU
Power Supply			Φ, #, V, Hz	1,2,220-240,50/60	1,2,220-240,50/60	1,2,220-240,50/60
Performance	Capacity	Cooling	kW	1.5	2.2	2.8
			Btu/h	5,100	7,500	9,600
		Heating	kW	1.7	2.5	3.2
			Btu/h	5,800	8,500	10,900
Power	Power Input	Cooling	W	20.0	24.0	30.0
		Heating		20.0	24.0	30.0
	Current Input	Cooling	A	0.13	0.16	0.2
		Heating		0.13	0.16	0.2
	Current	MCA	A	0.16	0.20	0.25
		MFA		15.0	15.0	15.0
Heat exchanger	Type		-	F&T	F&T	F&T
	Material	Fin	-	Al	Al	Al
		Tube	-	Cu	Cu	Cu
	Fin Treatment		-	Green Hydrophile	Green Hydrophile	Green Hydrophile
Fan	Type		-	Crossflow Fan	Crossflow Fan	Crossflow Fan
	Quantity		ea	1	1	1
	Air Flow Rate	H/M/L	CMM	4.9/4.5/4.1	5.7/5.0/4.5	8.5/7.7/6.9
			l/s	81.7/75.0/68.3	95.0/83.3/75.0	141.7/128.3/115.0
Fan Motor	Type		-	BLDC	BLDC	BLDC
	Output x n		W	27	27	27
Piping Connections	Liquid Pipe		Type	Flare connection	Flare connection	Flare connection
			Φ, mm (inch)	6.35 (1/4)	6.35 (1/4)	6.35 (1/4)
	Gas Pipe		Type	Flare connection	Flare connection	Flare connection
			Φ, mm (inch)	12.7 (1/2)	12.7 (1/2)	12.7 (1/2)
Drain Pipe		Φ,mm	ID 18mm Hose	ID 18mm Hose	ID 18mm Hose	
Wiring connections	Communication	Minimum	mm <sup>2</sup>	0.75	0.75	0.75
		Remark	-	F1, F2	F1, F2	F1, F2
Refrigerant	Type		-	R32	R32	R32
	Electronic Expansion Valve		-	EEV INCLUDED	EEV INCLUDED	EEV INCLUDED
Sound	Sound Pressure	High/Mid/Low/Windfree	dB(A)	31/30/27/26	34/32/30/27	34/33/32/26
	Sound Power	Cooling		50	51	52
Dimensions	Net Weight		kg	9.0	8.7	9.5
	Shipping Weight		kg	10.5	10.5	11.0
	Net Dimensions (W×H×D)		mm	820 x 299 x 215	820 x 299 x 215	820 x 299 x 215
	Shipping Dimensions (W×H×D)		mm	880 x 290 x 375	880 x 290 x 375	880 x 290 x 375
Additional Accessories			-	-	-	-
	Drain pump	Max. lifting Height / Displacement	mm / Liter/h	-	-	-
		EASY FILTER PLUS		-	-	-

### NOTE

- Specification may be subject to change without prior notice.
  - 1) Capacities are based on (Equivalent refrigerant piping 7.5m, Level differences 0m);
    - Cooling : Indoor temperature 27°C DB, 19°C WB / Outdoor temperature 35°C DB, 24°C WB
    - Heating : Indoor temperature 20°C DB, 15°C WB / Outdoor temperature 7°C DB, 6°C WB
  - 2) Sound level was acquired in an anechoic room. Thus actual noise level may be different depending on the installation conditions.
  - 3) These products contain R32 (GWP=675) which is fluorinated greenhouse gas.
  - 4) Select wire size based on the value of MCA

# 1. Specification

## Wall mounted

Model Name				AM036DNVDKG/EU	AM045DNVDKG/EU	AM056DNVDKG/EU
Power Supply			Φ, #, V, Hz	1,2,220-240,50/60	1,2,220-240,50/60	1,2,220-240,50/60
Performance	Capacity	Cooling	kW	3.6	4.5	5.6
			Btu/h	12,300	15,400	19,100
		Heating	kW	4.0	5.0	6.3
			Btu/h	13,600	17,100	21,500
Power	Power Input	Cooling	W	37.0	40.0	52.0
		Heating		37.0	40.0	52.0
	Current Input	Cooling	A	0.25	0.27	0.35
		Heating		0.25	0.27	0.35
	Current	MCA	A	0.31	0.34	0.44
		MFA		15.0	15.0	15.0
Heat exchanger	Type		-	F&T	F&T	F&T
	Material	Fin	-	Al	Al	Al
		Tube	-	Cu	Cu	Cu
	Fin Treatment		-	Green Hydrophile	Green Hydrophile	Green Hydrophile
Fan	Type		-	Crossflow Fan	Crossflow Fan	Crossflow Fan
	Quantity		ea	1	1	1
	Air Flow Rate	H/M/L	CMM	10.3/9.1/8.3	12.5/11.4/10.5	15.7/13.8/12.0
l/s			171.7/151.7/138.3	208.3/190.0/175.0	261.7/230.0/200.0	
Fan Motor	Type		-	BLDC	BLDC	BLDC
	Output x n		W	27	27	27
Piping Connections	Liquid Pipe		Type	Flare connection	Flare connection	Flare connection
			Φ, mm (inch)	6.35 (1/4)	6.35 (1/4)	6.35 (1/4)
	Gas Pipe		Type	Flare connection	Flare connection	Flare connection
			Φ, mm (inch)	12.7 (1/2)	12.7 (1/2)	12.7 (1/2)
Drain Pipe		Φ,mm	ID 18mm Hose	ID 18mm Hose	ID 18mm Hose	
Wiring connections	Communication	Minimum	mm <sup>2</sup>	0.75	0.75	0.75
		Remark	-	F1, F2	F1, F2	F1, F2
Refrigerant	Type		-	R32	R32	R32
	Electronic Expansion Valve		-	EEV INCLUDED	EEV INCLUDED	EEV INCLUDED
Sound	Sound Pressure	High/Mid/Low/Windfree	dB(A)	40/36/34/26	37/34/33/29	40/37/34/29
	Sound Power	Cooling		56	55	58
Dimensions	Net Weight		kg	9.5	12.0	12.0
	Shipping Weight		kg	11.0	14.0	14.0
	Net Dimensions (W×H×D)		mm	820 x 299 x 215	1,055 x 299 x 215	1,055 x 299 x 215
	Shipping Dimensions (W×H×D)		mm	880 x 290 x 375	1,115 x 290 x 375	1,115 x 290 x 375
Additional Accessories			-	-	-	-
	Drain pump	Max. lifting Height / Displacement	mm / Liter/h	-	-	-
		EASY FILTER PLUS		-	-	-

### NOTE

- Specification may be subject to change without prior notice.
  - 1) Capacities are based on (Equivalent refrigerant piping 7.5m, Level differences 0m);
    - Cooling : Indoor temperature 27°C DB, 19°C WB / Outdoor temperature 35°C DB, 24°C WB
    - Heating : Indoor temperature 20°C DB, 15°C WB / Outdoor temperature 7°C DB, 6°C WB
  - 2) Sound level was acquired in an anechoic room. Thus actual noise level may be different depending on the installation conditions.
  - 3) These products contain R32 (GWP=675) which is fluorinated greenhouse gas.
  - 4) Select wire size based on the value of MCA

# 1. Specification

## Wall mounted

Model Name				AM071DNVDKG/EU	AM082DNVDKG/EU
Power Supply			Φ, #, V, Hz	1,2,220-240,50/60	1,2,220-240,50/60
Performance	Capacity	Cooling	kW	6.8	8.2
			Btu/h	23,200	28,000
		Heating	kW	7.0	8.5
			Btu/h	23,900	29,000
Power	Power Input	Cooling	W	60.0	65.0
		Heating		60.0	65.0
	Current Input	Cooling	A	0.4	0.43
		Heating		0.4	0.43
	Current	MCA	A	0.50	0.54
		MFA		15.0	15.0
Heat exchanger	Type		-	F&T	F&T
	Material	Fin	-	Al	Al
		Tube	-	Cu	Cu
Fin Treatment		-	Green Hydrophile	Green Hydrophile	
Fan	Type		-	Crossflow Fan	Crossflow Fan
	Quantity		ea	1	1
	Air Flow Rate	H/M/L	CMM	16.8/15.0/13.2	17.5/15.6/13.8
l/s			280.0/250.0/220.0	291.7/260.0/230.0	
Fan Motor	Type		-	BLDC	BLDC
	Output x n		W	27	27
Piping Connections	Liquid Pipe		Type	Flare connection	Flare connection
			Φ, mm (inch)	9.52 (3/8)	9.52 (3/8)
	Gas Pipe		Type	Flare connection	Flare connection
			Φ, mm (inch)	15.88 (5/8)	15.88 (5/8)
Drain Pipe		Φ,mm	ID 18mm Hose	ID 18mm Hose	
Wiring connections	Communication	Minimum	mm <sup>2</sup>	0.75	0.75
		Remark	-	F1, F2	F1, F2
Refrigerant	Type		-	R32	R32
	Electronic Expansion Valve		-	EEV INCLUDED	EEV INCLUDED
Sound	Sound Pressure	High/Mid/Low/Windfree	dB(A)	43/40/37/29	46/45/43/30
	Sound Power	Cooling		62	64
Dimensions	Net Weight		kg	12.0	13.0
	Shipping Weight		kg	14.0	15.0
	Net Dimensions (W×H×D)		mm	1,055 x 299 x 215	1,055 x 299 x 215
	Shipping Dimensions (W×H×D)		mm	1,115 x 290 x 375	1,115 x 290 x 375
Additional Accessories	Drain pump	Max. lifting Height / Displacement	-	-	-
			mm / Liter/h	-	-
	EASY FILTER PLUS		-	-	-

### NOTE

- Specification may be subject to change without prior notice.
  - 1) Capacities are based on (Equivalent refrigerant piping 7.5m, Level differences 0m);
    - Cooling : Indoor temperature 27°C DB, 19°C WB / Outdoor temperature 35°C DB, 24°C WB
    - Heating : Indoor temperature 20°C DB, 15°C WB / Outdoor temperature 7°C DB, 6°C WB
  - 2) Sound level was acquired in an anechoic room. Thus actual noise level may be different depending on the installation conditions.
  - 3) These products contain R32 (GWP=675) which is fluorinated greenhouse gas.
  - 4) Select wire size based on the value of MCA

# 1. Specification

## Wall mounted

Model Name			AM093DNQDKG/EU	
Power Supply			Φ, #, V, Hz	1, 2, 220-240, 50/60
Performance	Capacity	Cooling	kW	9.3
			Btu/h	31,700
		Heating	kW	9.8
			Btu/h	33,400
Power	Power Input	Cooling	W	66
		Heating		76
	Current Input	Cooling	A	0.47
		Heating		0.54
	Current	MCA	A	0.68
		MFA		15
Heat exchanger	Type		-	Fin & Tube
	Material	Fin	-	Al
		Tube	-	Cu
	Fin Treatment		-	Green Hydrophile
Fan	Type		-	Crossflow Fan
	Quantity		EA	1
	Air Flow Rate	H/M/L	m <sup>3</sup> /min	23 / 20 / 17
			l/s	383 / 333 / 283
Fan Motor	Type		-	BLDC Motor
	Output x n		W	58
Piping Connections	Liquid Pipe	Type		Flare connection
		Φ, mm (inch)		9.52 (3/8)
	Gas Pipe	Type		Flare connection
		Φ, mm (inch)		15.88 (5/8)
	Heat insulation		-	Both liquid and gas pipes
Drain Pipe		Φ,mm	ID 18mm Hose	
Wiring connections	Communication	Min.	mm <sup>2</sup>	0.75
		Remark	-	F1, F2
Refrigerant	Type		-	R32
	Electronic Expansion Valve		-	EEV INCLUDED
Sound	Sound Pressure Level	H/M/L	dB(A)	49/46/42
	Sound Power	Cooling		
Dimensions	Net Weight		kg	19.0
	Shipping Weight		kg	22.0
	Net Dimensions (W×H×D)		mm	1,280 x 345 x 253
	Shipping Dimensions (W×H×D)		mm	1,352 x 326 x 420
Casing	Material		-	HIPS

### NOTE

- Specification may be subject to change without prior notice.
  - 1) Capacities are based on (Equivalent refrigerant piping 7.5m, Level differences 0m);
    - Cooling : Indoor temperature 27°C DB, 19°C WB / Outdoor temperature 35°C DB, 24°C WB
    - Heating : Indoor temperature 20°C DB, 15°C WB / Outdoor temperature 7°C DB, 6°C WB
  - 2) Sound level was acquired in an anechoic room. Thus actual noise level may be different depending on the installation conditions.
  - 3) These products contain R32 (GWP=675) which is fluorinated greenhouse gas.
  - 4) Select wire size based on the value of MCA

## 2. Summary Table

### Wall mounted

#### Performance Characteristics

Model Code	Net Weight (kg)	Fan Speed	Nominal Capacity			Airflow (CMM)	Sound Pressure	Sound Power
			Cooling (kW)	Sensible	Heating			
AM015DNVDKG/EU	9.0	High	1.5	1.0	1.7	4.9	31	50
		Mid	1.2	0.9	1.6	4.5	30	-
		Low	1.0	0.8	1.5	4.1	27	-
AM022DNVDKG/EU	8.7	High	2.2	1.5	2.5	5.7	34	51
		Mid	1.6	1.4	2.3	5.0	32	-
		Low	1.3	1.2	2.2	4.5	30	-
AM028DNVDKG/EU	9.5	High	2.8	1.9	3.2	8.5	34	52
		Mid	2.1	1.7	3.0	7.7	33	-
		Low	1.7	1.5	2.8	6.9	32	-
AM036DNVDKG/EU	9.5	High	3.6	2.4	4.0	10.3	40	56
		Mid	2.6	2.2	3.8	9.1	36	-
		Low	2.1	1.8	3.5	8.3	34	-
AM045DNVDKG/EU	12.0	High	4.5	3.1	5.0	12.5	37	55
		Mid	3.2	2.7	4.7	11.4	34	-
		Low	2.6	2.1	4.5	10.5	33	-
AM056DNVDKG/EU	12.0	High	5.6	3.8	6.3	15.7	40	58
		Mid	4.0	3.3	6.0	13.8	37	-
		Low	3.1	2.7	5.6	12.0	34	-
AM071DNVDKG/EU	12.0	High	6.8	4.6	7.0	16.8	43	62
		Mid	4.7	4.0	6.6	15.0	40	-
		Low	3.7	2.9	6.3	13.2	37	-
AM082DNVDKG/EU	13.0	High	8.2	5.6	8.5	17.5	46	64
		Mid	6.4	5.2	7.9	15.6	45	-
		Low	5.3	4.4	7.5	13.8	43	-
AM093DNQDKG/EU	19.0	High	9.3	6.3	9.8	23.0	49	66
		Mid	7.2	5.2	9.1	20.0	46	-
		Low	6.0	4.6	8.4	17.0	42	-

#### NOTE

- Sound data is based on cooling operation.

#### Electric Characteristics

Model Code	Power Supply (Ø, #, V, Hz)	Power Input (W) (C / H)	Current Input (A) (C / H)	MCA (A)	MFA (A)	FLA (A)
AM015DNVDKG/EU	1,2,220-240,50/60	20 / 20	0.13 / 0.13	0.16	15	0.13
AM022DNVDKG/EU	1,2,220-240,50/60	24 / 24	0.16 / 0.16	0.20	15	0.16
AM028DNVDKG/EU	1,2,220-240,50/60	30 / 30	0.20 / 0.20	0.25	15	0.20
AM036DNVDKG/EU	1,2,220-240,50/60	37 / 37	0.25 / 0.25	0.31	15	0.25
AM045DNVDKG/EU	1,2,220-240,50/60	40 / 40	0.27 / 0.27	0.34	15	0.27
AM056DNVDKG/EU	1,2,220-240,50/60	52 / 52	0.35 / 0.35	0.44	15	0.35
AM071DNVDKG/EU	1,2,220-240,50/60	60 / 60	0.40 / 0.40	0.50	15	0.40
AM082DNVDKG/EU	1,2,220-240,50/60	65 / 65	0.43 / 0.43	0.54	15	0.43
AM093DNQDKG/EU	1,2,220-240,50/60	66 / 76	0.47 / 0.54	0.68	15	0.54

#### NOTE

- MCA : Minimum circuit amperes
- MFA : Maximum fuse amperes
- Select wire size based on the value of MCA

# 3. Capacity Table

## Wall mounted

### Cooling

TC : Total Capacity, SHC : Sensible Heat Capacity

Capacity Index	Outdoor Air Temp. (°C,DB)	Indoor temperature													
		20(°C,DB)		23(°C,DB)		26(°C,DB)		27(°C,DB)		28(°C,DB)		30(°C,DB)		32(°C,DB)	
		14(°C,WB)		16(°C,WB)		18(°C,WB)		19(°C,WB)		20(°C,WB)		22(°C,WB)		24(°C,WB)	
		TC	SHC	TC	SHC	TC	SHC	TC	SHC	TC	SHC	TC	SHC	TC	SHC
015	35	1.0	0.9	1.2	1.0	1.4	1.0	1.5	1.0	1.6	1.0	1.6	1.1	1.8	1.0
022	35	1.5	1.3	1.8	1.5	2.1	1.5	2.2	1.5	2.3	1.5	2.4	1.5	2.6	1.4
028	35	1.9	1.6	2.3	1.8	2.6	2.0	2.8	1.9	2.9	1.9	3.1	1.9	3.3	1.8
036	35	2.5	2.1	2.9	2.2	3.4	2.3	3.6	2.4	3.7	2.4	4.0	2.4	4.2	2.3
045	35	3.1	2.4	3.7	2.8	4.3	3.0	4.5	3.1	4.7	3.1	5.0	3.1	5.3	2.9
056	35	3.9	3.0	4.6	3.4	5.3	3.7	5.6	3.8	5.8	3.8	6.2	3.8	6.6	3.5
071	35	4.5	4.1	5.4	4.6	6.3	4.6	6.8	4.6	7.3	4.6	7.3	5.1	8.2	4.6
082	35	5.7	4.4	6.7	5.0	7.8	5.4	8.2	5.6	8.5	5.6	9.1	5.6	9.7	5.1
093	35	6.4	5.1	7.5	5.6	8.8	6.2	9.3	6.3	9.6	6.3	10.3	6.2	10.9	5.8

### Heating

TC : Total Capacity (kW)

Capacity Index	Outdoor Air Temp. (°C)		Indoor temperature (°C,DB)				
			16(°C,DB)	18(°C,DB)	20(°C,DB)	22(°C,DB)	24(°C,DB)
	DB	WB	TC	TC	TC	TC	TC
015	7.0	6.0	1.9	1.8	1.7	1.6	1.5
022	7.0	6.0	2.8	2.7	2.5	2.3	2.2
028	7.0	6.0	3.3	3.2	3.2	3.0	2.7
036	7.0	6.0	4.1	4.1	4.0	3.7	3.4
045	7.0	6.0	5.2	5.1	5.0	4.6	4.2
056	7.0	6.0	6.5	6.4	6.3	5.8	5.3
071	7.0	6.0	7.8	7.4	7.0	6.6	6.2
082	7.0	6.0	8.8	8.6	8.5	7.8	7.2
093	7.0	6.0	10.1	9.9	9.8	9.1	8.3

### NOTE

- The performance table shows the average value of each conditions.

# 4. Dimensional Drawing

Wall mounted

AM015DNVDKG/EU, AM022DNVDKG/EU, AM028DNVDKG/EU, AM036DNVDKG/EU

Units : mm [inches]

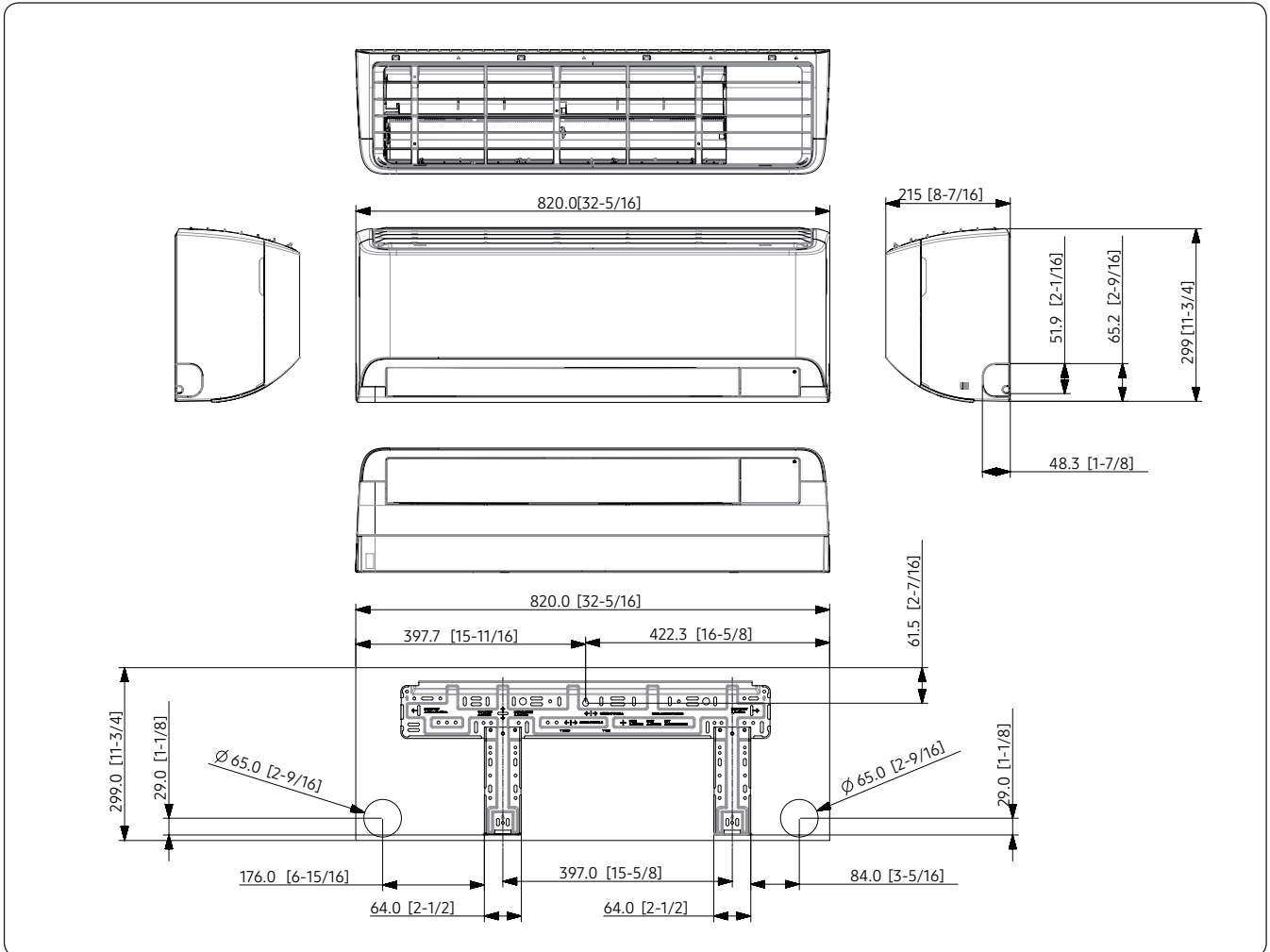

# 4. Dimensional Drawing

Wall mounted

AM045DNVDKG/EU, AM056DNVDKG/EU, AM071DNVDKG/EU, AM082DNVDKG/EU

Units : mm [inches]

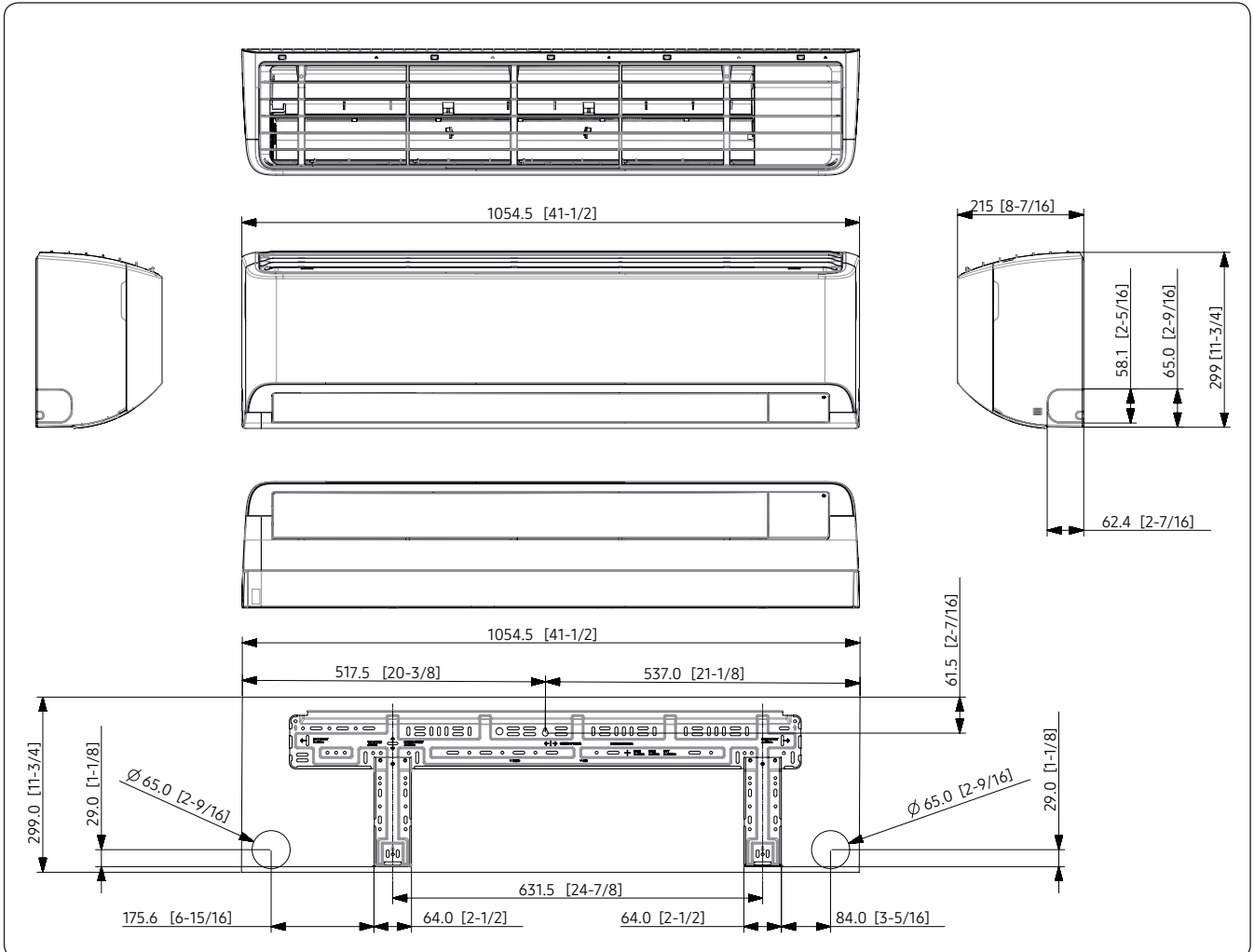

# 4. Dimensional Drawing

Wall mounted

AM093DNQDKG/EU

Units : mm [inches]

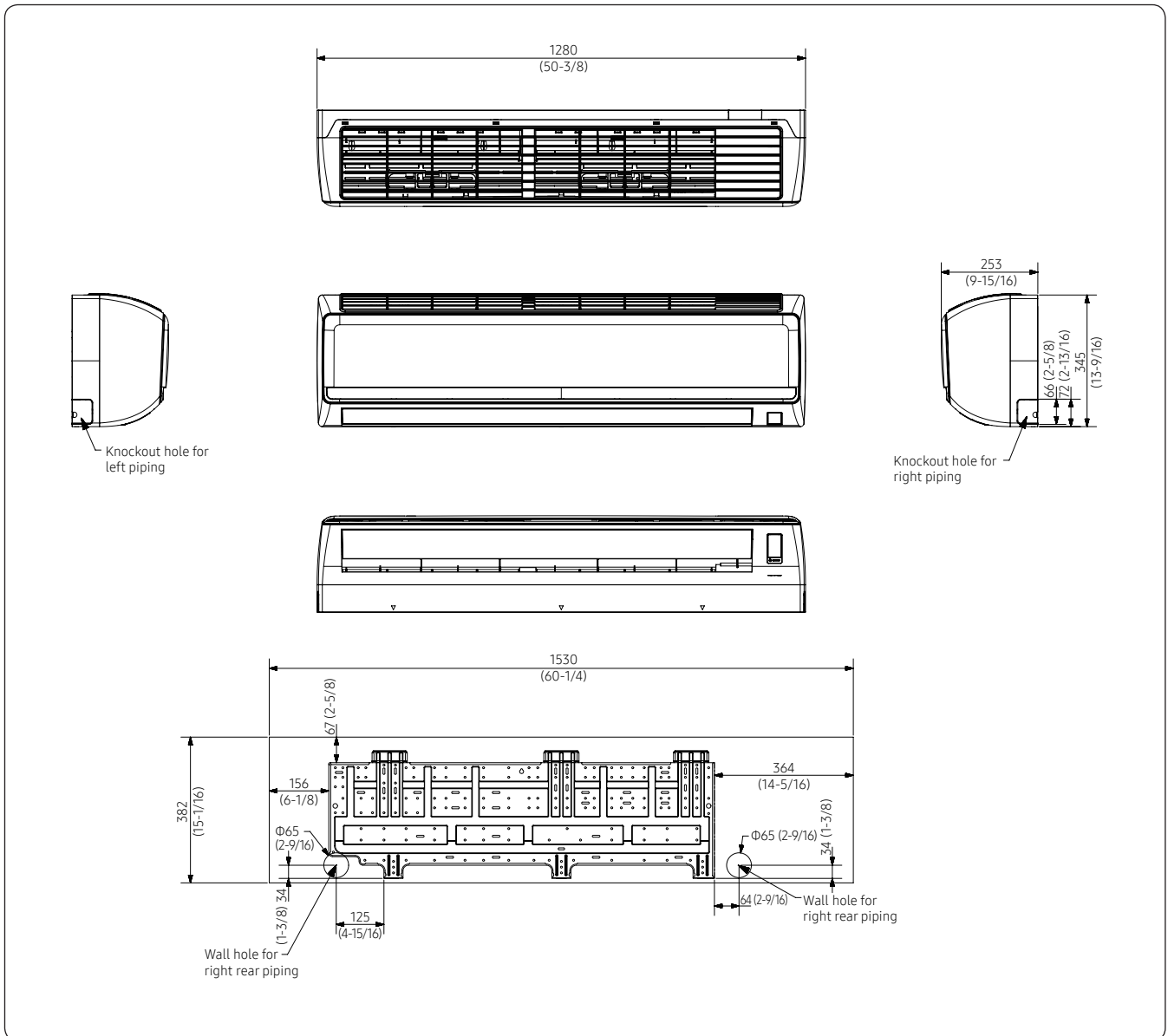

# 5. Center of Gravity

Wall mounted

AM015DNVDKG/EU, AM022DNVDKG/EU, AM028DNVDKG/EU, AM036DNVDKG/EU

Unit: mm (inches)

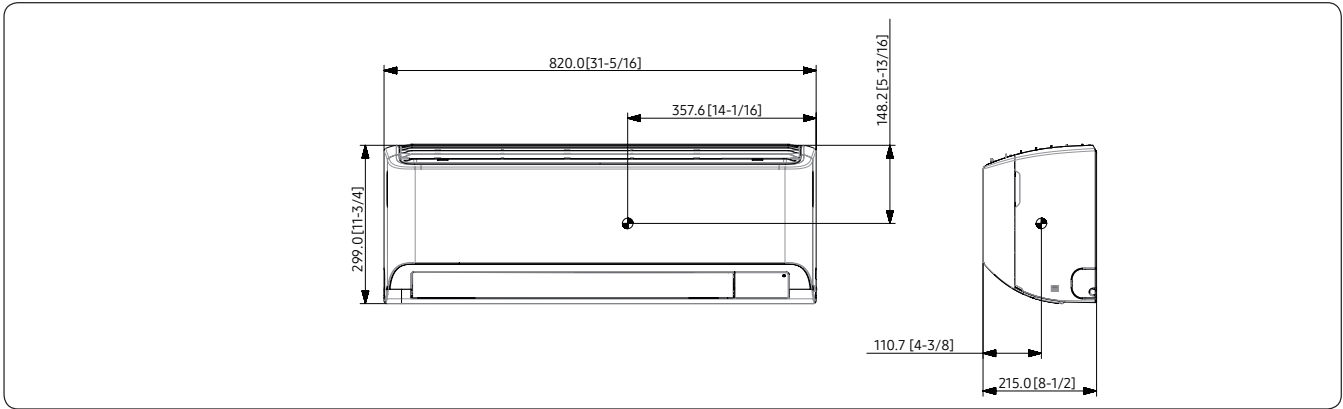

AM045DNVDKG/EU, AM056DNVDKG/EU, AM071DNVDKG/EU, AM082DNVDKG/EU

Unit: mm (inches)

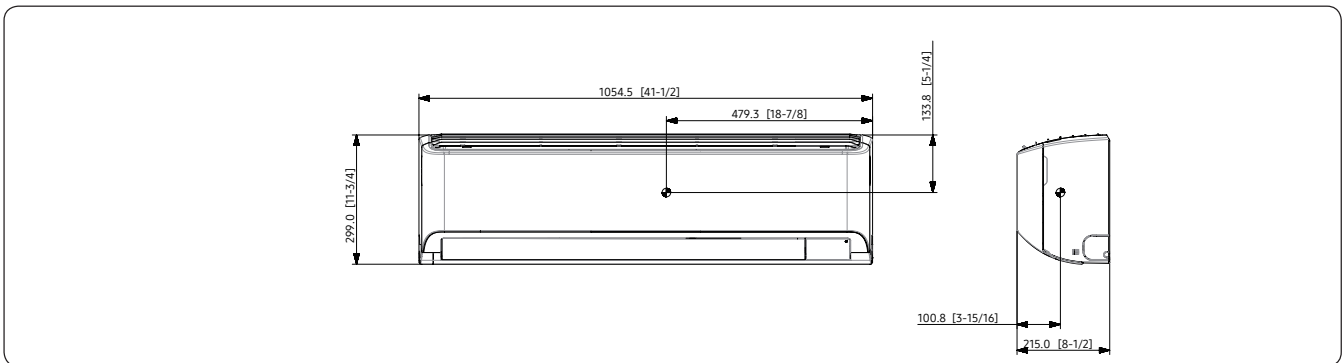

AM093DNQDKG/EU

Unit: mm (inch)

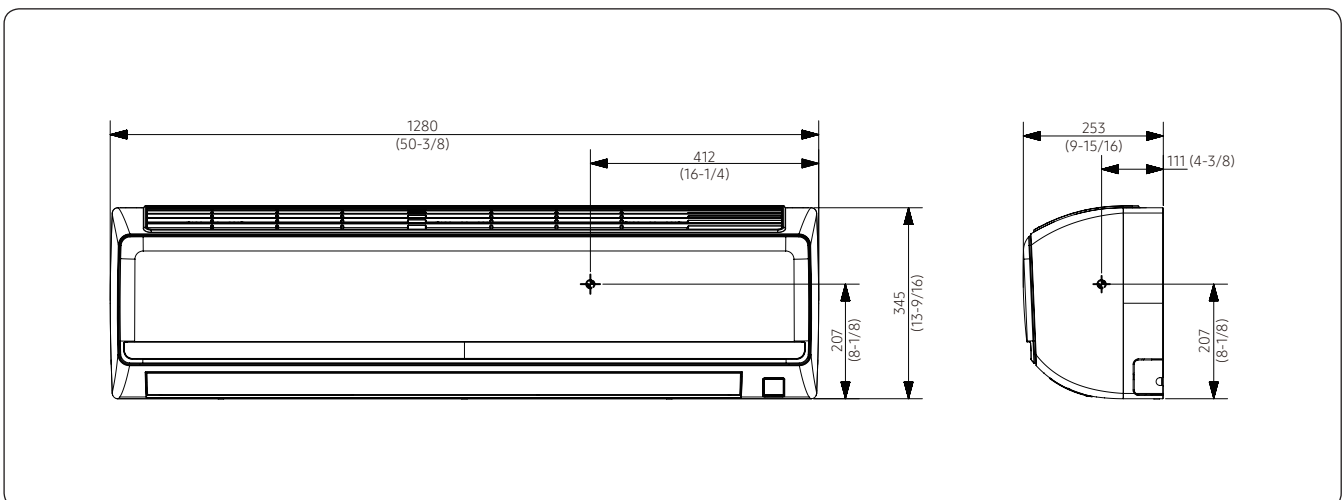

# 6. Electrical Wiring Diagram

## Wall mounted

AM015DNVDKG/EU, AM022DNVDKG/EU, AM028DNVDKG/EU, AM036DNVDKG/EU, AM045DNVDKG/EU  
AM056DNVDKG/EU, AM071DNVDKG/EU, AM082DNVDKG/EU

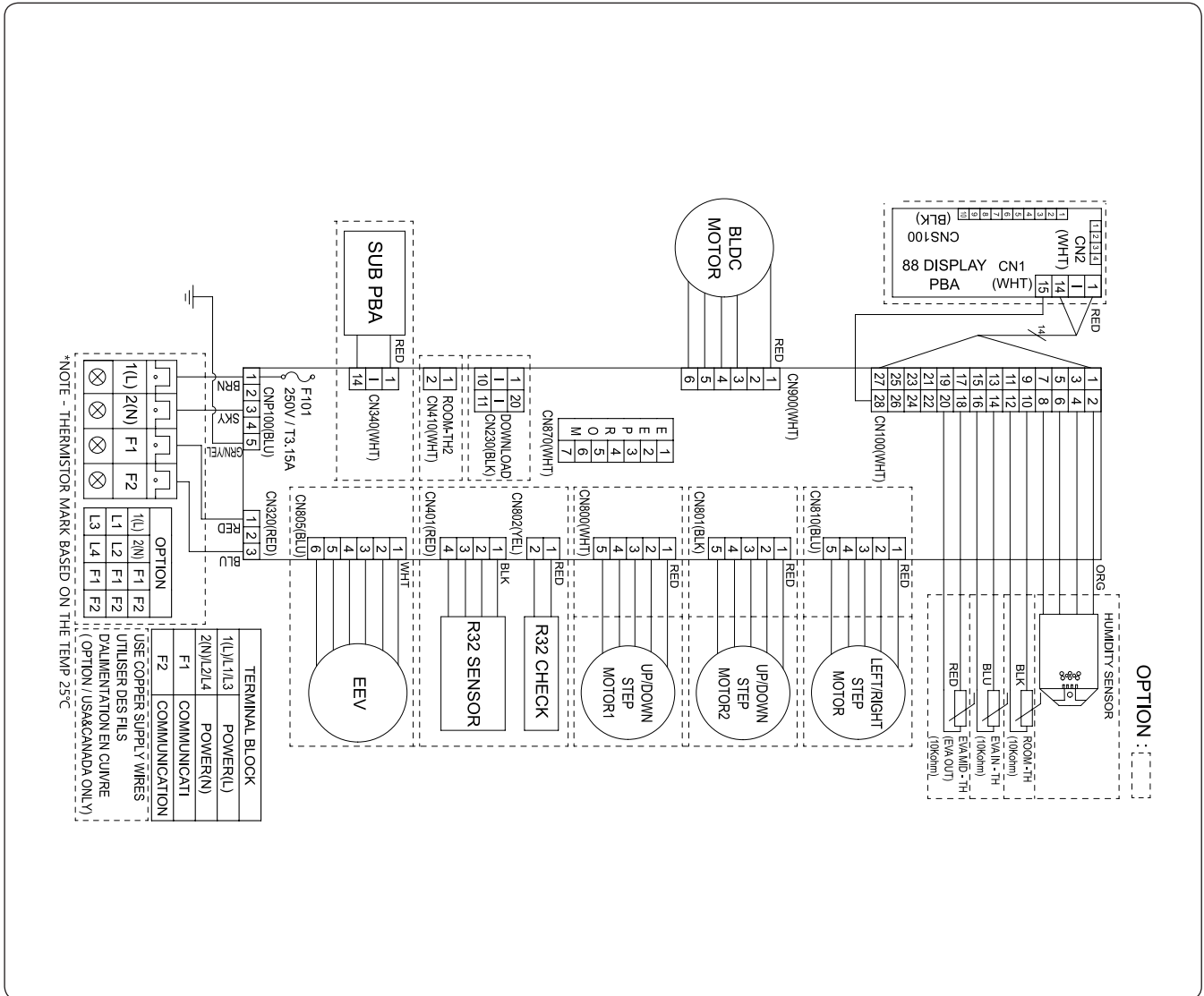

SUB PBA	Printed Circuit Board(SUB)	EEV	Electronic expansion valve	EVA-OUT(10K)	Thermistor EVA OUT(10K)
MOTOR	BLDC	ROOM(10K)	Thermistor ROOM In(10K)	EVA-IN(10K)	Thermistor EVA IN(10K)

### NOTE

- This wiring diagram applies only to the Indoor unit.
- Symbols show as follow :  
BLK: black, RED: red, BLU: blue, WHT: white, YEL: yellow, BRN: brown, sky: sky blue, GRN: green
- For connection wiring indoor-outdoor transmission F1-F2, indoor-wired remote controller transmission F3-F4.

-  Protective earth(SCREW)

EARTH EARTH

# 6. Electrical Wiring Diagram

Wall mounted

AM093DNQDKG/EU

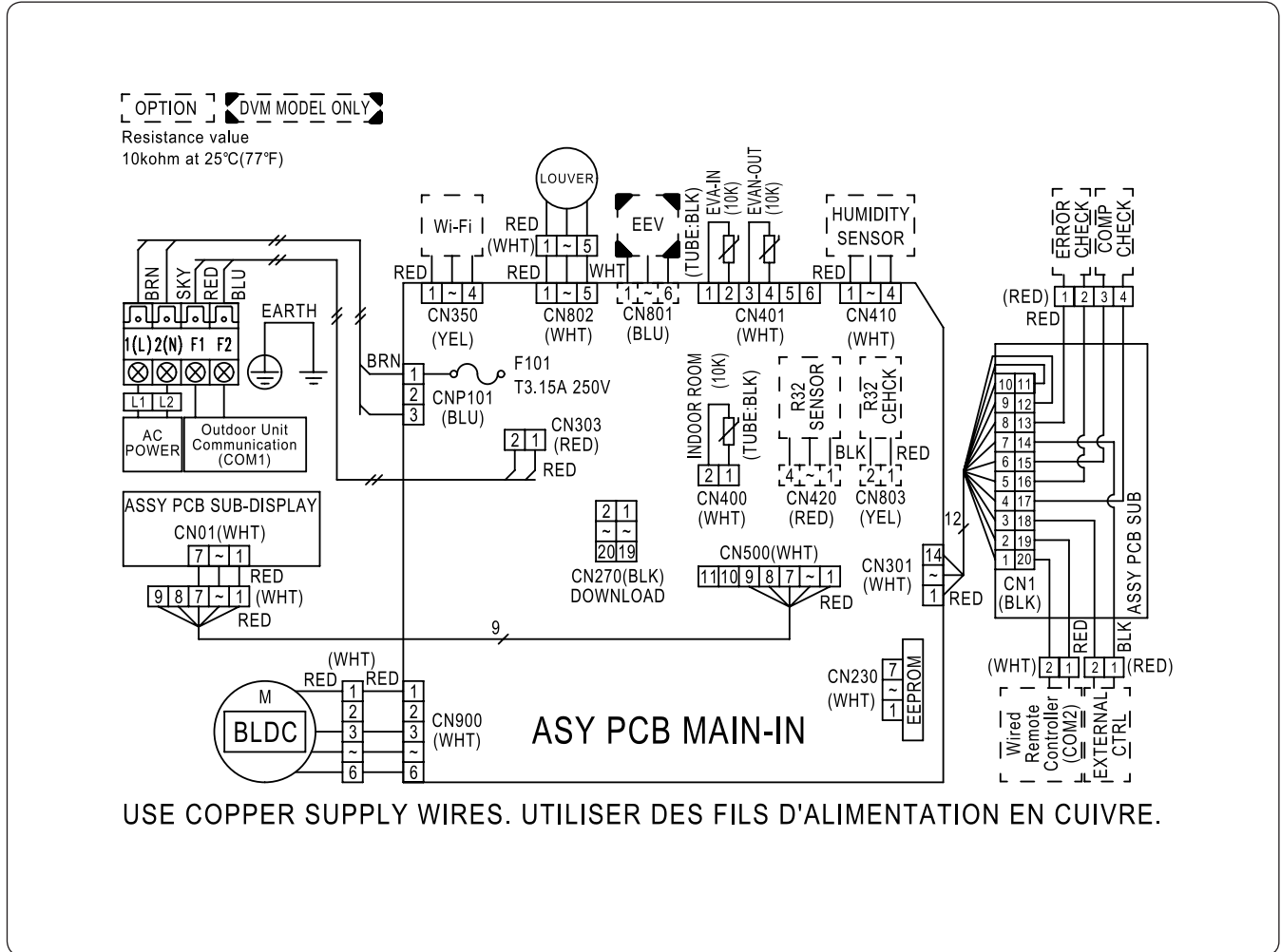

<b>MAIN PCB</b>	Print circuit board(MAIN)	<b>EEV</b>	Electronics expansion valve	<b>EVA-IN TEMP</b>	Thermistor EVAPORATE
<b>DISPLAY</b>	Print circuit board(DISPLAY)	<b>M-BLDC</b>	BLDC Motor	<b>EVA-OUT TEMP</b>	Thermistor EVAPORATE
<b>ASSY PCB SUB</b>	Print circuit board(SUB COMM)	<b>ROOM-TEMP</b>	Thermistor AMBIENT		

## NOTE

- This wiring diagram applies only to the Indoor unit.
- Colors blk: black, red: red, blu: blue, wht: white, yel: yellow, brn: brown, sky: skyblue
- When operating, don't shortcircuit the protection device (High Pressure switch)
- For connection wiring indoor-outdoor transmission F1-F2, outdoor-outdoor transmission OF1-OF2, refer to the installation manual.
- $\oplus$  : Protective earth(screw),  $\square$  : connector,  $\diagdown$  : The wire quantity

# 7. Sound Data

## Wall mounted

### Sound Pressure level

Unit: dB(A)

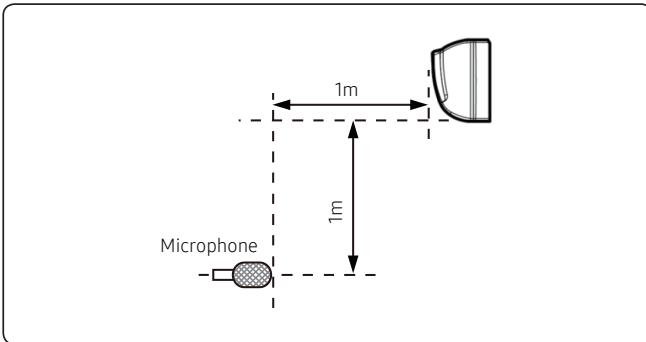

Model	High	Mid	Low	Wind-Free
AM015DNVDKG/EU	31	30	27	26
AM022DNVDKG/EU	34	32	30	27
AM028DNVDKG/EU	34	33	32	26
AM036DNVDKG/EU	40	36	34	26

- NR Curve

1) AM015DNVDKG/EU

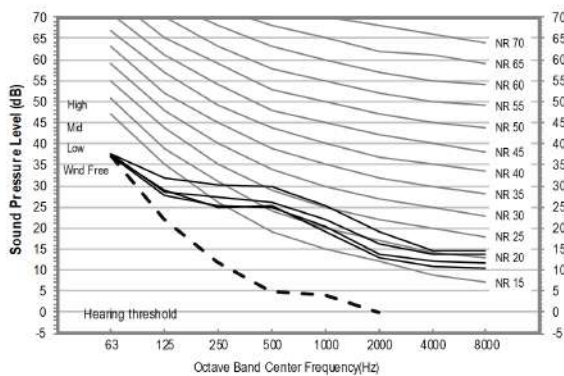

2) AM022DNVDKG/EU

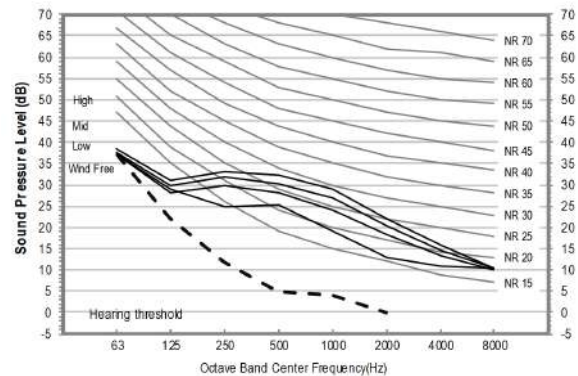

3) AM028DNVDKG/EU

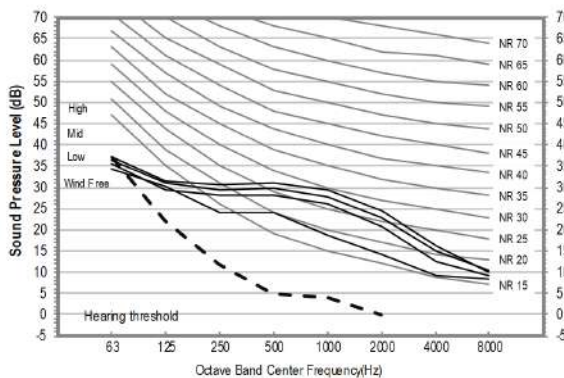

4) AM036DNVDKG/EU

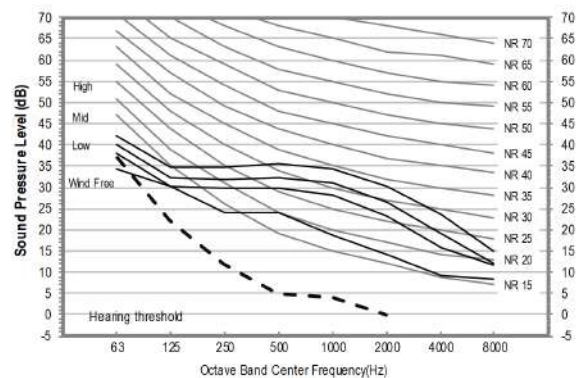

### NOTE

- Specifications may be subject to change without prior notice.
  - Sound pressure level is obtained in an anechoic room.
  - Sound pressure level is a relative value, depending on the distance and acoustic environment.
  - Sound pressure level may differ depending on operation condition.
  - dB(A) = A weighted sound pressure level
  - Reference acoustic pressure 0 dB = 20μPa

※ The concept of Wall mounted with EEV included is commercial application only. Residential application such as Hotel, Hospital, Houses where the very quiet surrounding is required should be avoided to prevent a noise claim.

# 7. Sound Data

## Wall mounted

### Sound Pressure level

Unit: dB(A)

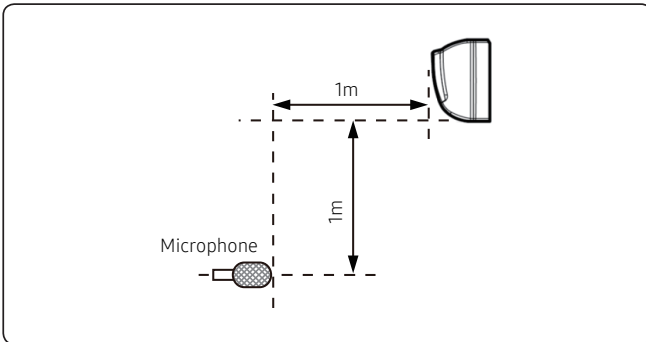

Model	High	Mid	Low	Wind-Free
AM045DNVDKG/EU	37	34	33	29
AM056DNVDKG/EU	40	37	34	29
AM071DNVDKG/EU	43	40	37	29
AM082DNVDKG/EU	46	45	43	30

- NR Curve

1) AM045DNVDKG/EU

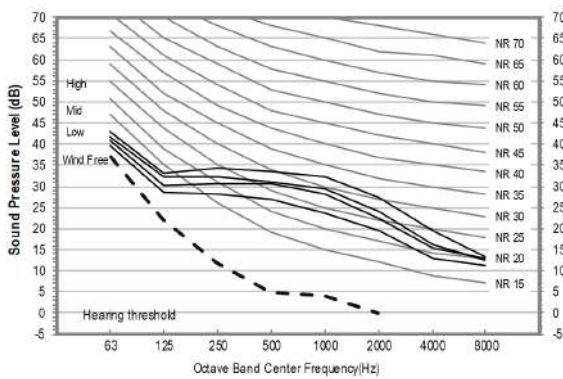

2) AM056DNVDKG/EU

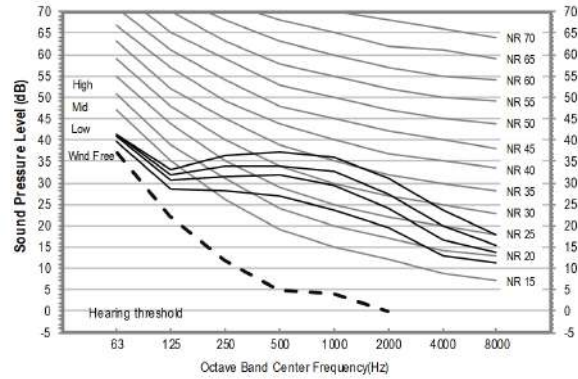

3) AM071DNVDKG/EU

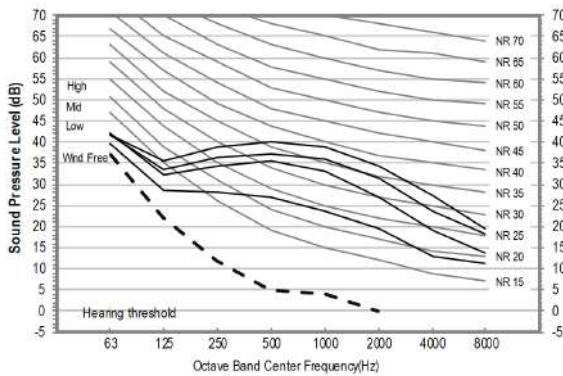

4) AM082DNVDKG/EU

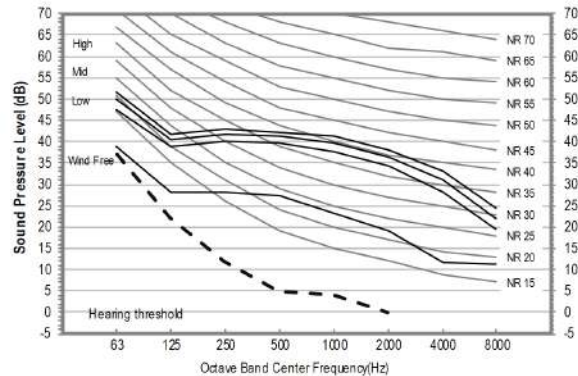

### NOTE

- Specifications may be subject to change without prior notice.
  - Sound pressure level is obtained in an anechoic room.
  - Sound pressure level is a relative value, depending on the distance and acoustic environment.
  - Sound pressure level may differ depending on operation condition.
  - dB(A) = A weighted sound pressure level
  - Reference acoustic pressure 0 dB = 20μPa

※ The concept of Wall mounted with EEV included is commercial application only. Residential application such as Hotel, Hospital, Houses where the very quiet surrounding is required should be avoided to prevent a noise claim.

# 7. Sound Data

## Wall mounted

### Sound Pressure level

Unit: dB(A)

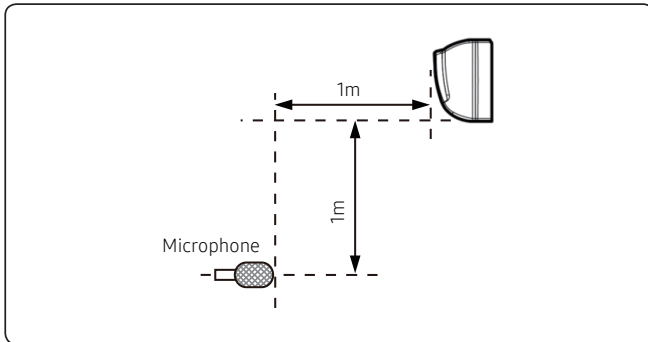

Model	High	Mid	Low
AM093DNQDKG/EU	49	46	42

- NR Curve

- 1) AM093DNQDKG/EU

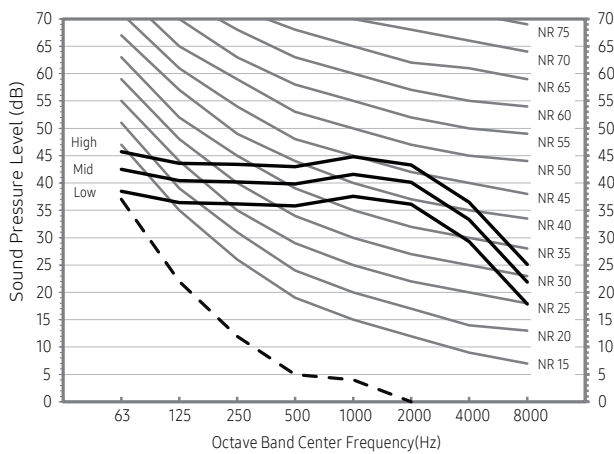

### NOTE

- Specifications may be subject to change without prior notice.
  - Sound pressure level is obtained in an anechoic room.
  - Sound pressure level is a relative value, depending on the distance and acoustic environment.
  - Sound pressure level may differ depending on operation condition.
  - dB(A) = A weighted sound pressure level
  - Reference acoustic pressure 0 dB = 20μPa

\* The concept of Wall mounted with EEV included is commercial application only. Residential application such as Hotel, Hospital, Houses where the very quiet surrounding is required should be avoided to prevent a noise claim.

# 7. Sound Data

## Wall mounted

### Sound Power level

**NOTE**

- Specifications may be subject to change without prior notice
  - Sound power level is an absolute value that a sound source generates.
  - dBA = A-weighted sound power level.
  - Reference power : 1pW.
  - Measured according to ISO 3741.

Unit: dB(A)

Model	Power
AM015DNVDKG/EU	50
AM022DNVDKG/EU	51
AM028DNVDKG/EU	52
AM036DNVDKG/EU	56

- NR Curve

1) AM015DNVDKG/EU

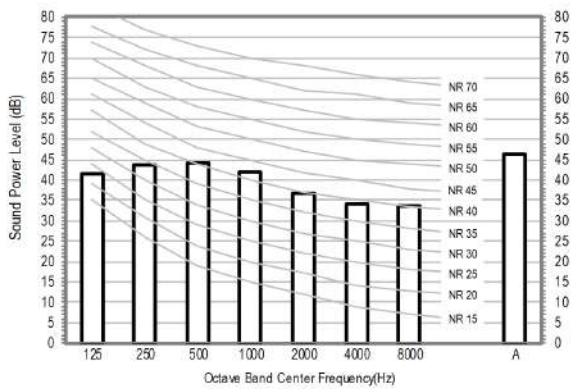

2) AM022DNVDKG/EU

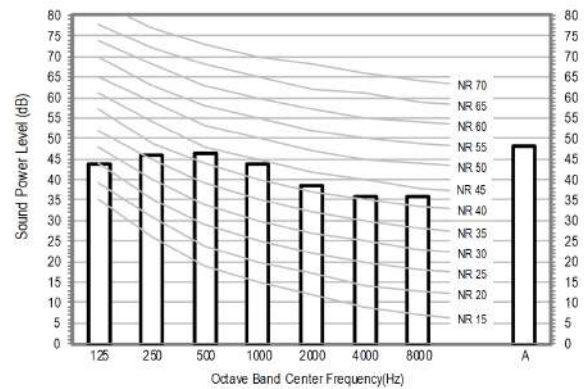

3) AM028DNVDKG/EU

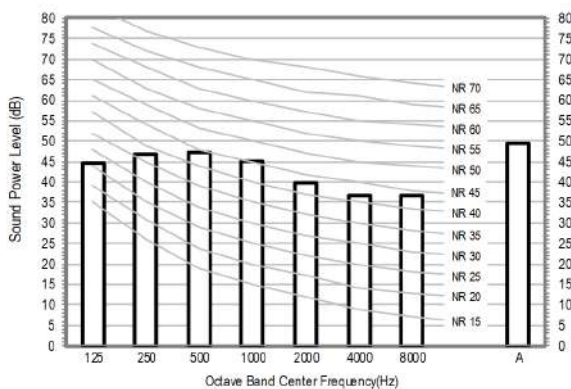

4) AM036DNVDKG/EU

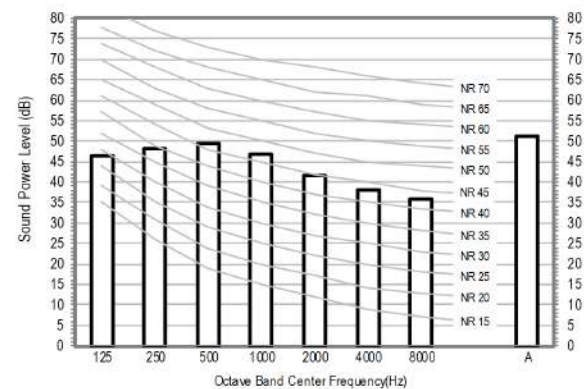

※ The concept of Wall mounted with EEV included is commercial application only. Residential application such as Hotel, Hospital, Houses where the very quiet surrounding is required should be avoided to prevent a noise claim.

# 7. Sound Data

## Wall mounted

### Sound Power level

**NOTE**

- Specifications may be subject to change without prior notice
  - Sound power level is an absolute value that a sound source generates.
  - dBA = A-weighted sound power level.
  - Reference power : 1pW.
  - Measured according to ISO 3741.

Unit: dB(A)

Model	Power
AM045DNVDKG/EU	55
AM056DNVDKG/EU	58
AM071DNVDKG/EU	62
AM082DNVDKG/EU	64

- NR Curve

1) AM045DNVDKG/EU

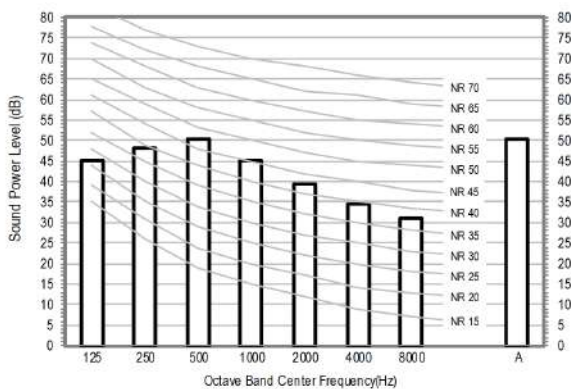

2) AM056DNVDKG/EU

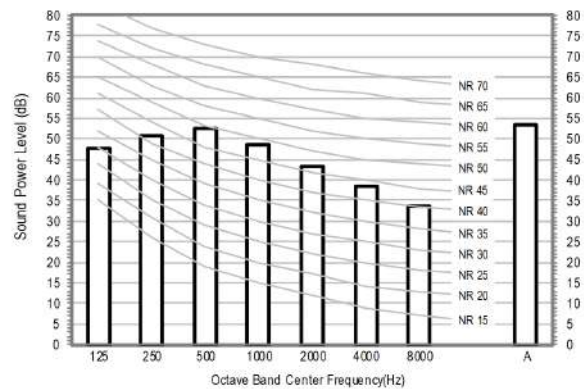

3) AM071DNVDKG/EU

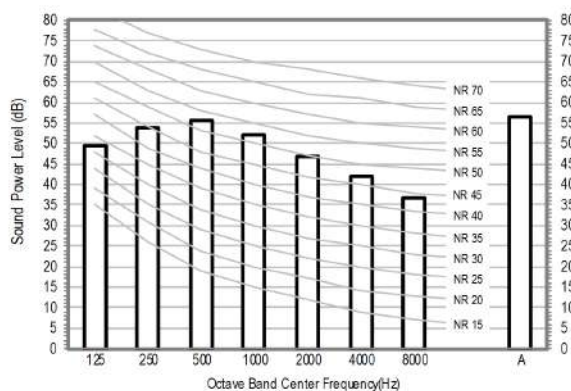

4) AM082DNVDKG/EU

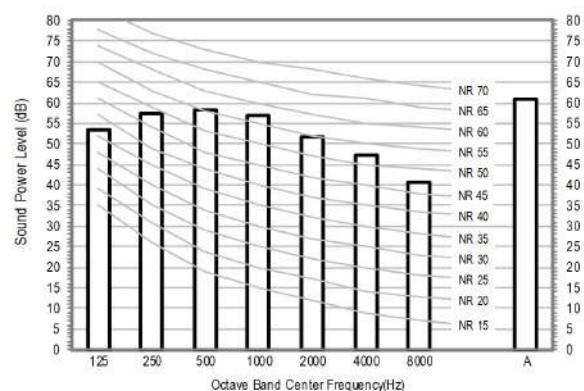

※ The concept of Wall mounted with EEV included is commercial application only. Residential application such as Hotel, Hospital, Houses where the very quiet surrounding is required should be avoided to prevent a noise claim.

# 7. Sound Data

## Wall mounted

### Sound Power level

**NOTE**

- Specifications may be subject to change without prior notice
  - Sound power level is an absolute value that a sound source generates.
  - dBA = A-weighted sound power level.
  - Reference power : 1pW.
  - Measured according to ISO 3741.

Unit: dB(A)

Model	Power
AM093DNQDKG/EU	66

- NR Curve

1) AM093DNQDKG/EU

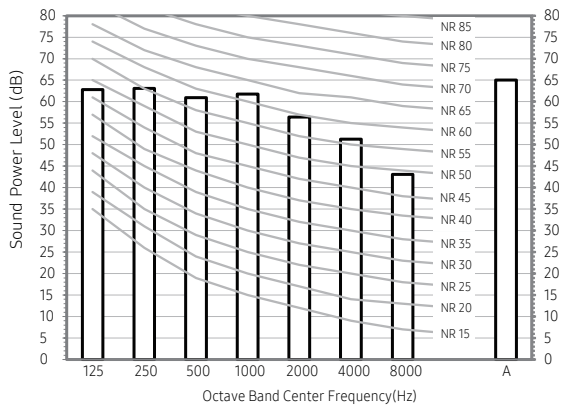

※ The concept of Wall mounted with EEV included is commercial application only. Residential application such as Hotel, Hospital, Houses where the very quiet surrounding is required should be avoided to prevent a noise claim.

# 8. Temperature and air flow distribution

## Wall mounted

### AM015DNVDKG/EU

1) Cooling air velocity distribution

Discharge angle : 20°

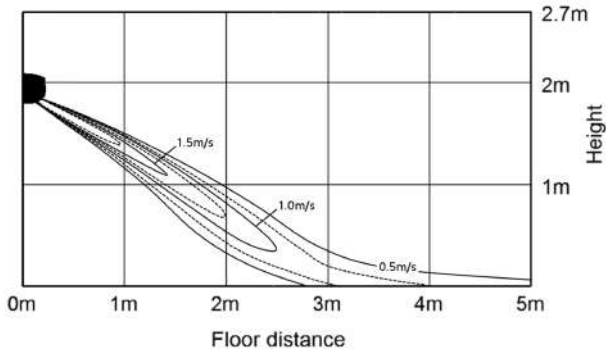

2) Cooling temperature distribution

Discharge angle : 20°

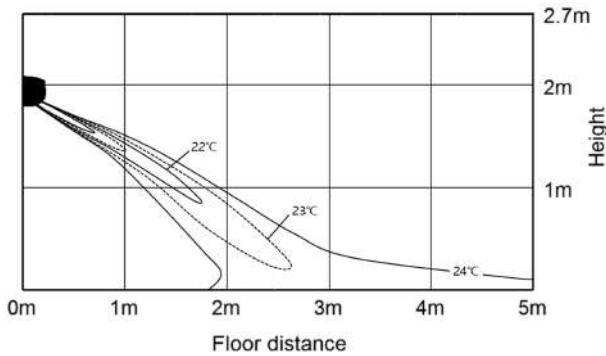

3) Heating air velocity distribution

Discharge angle : 30°

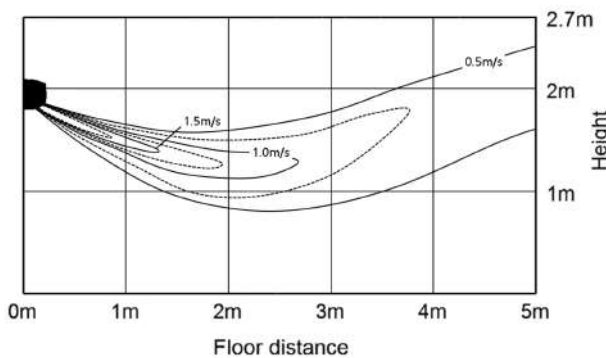

4) Heating temperature distribution

Discharge angle : 30°

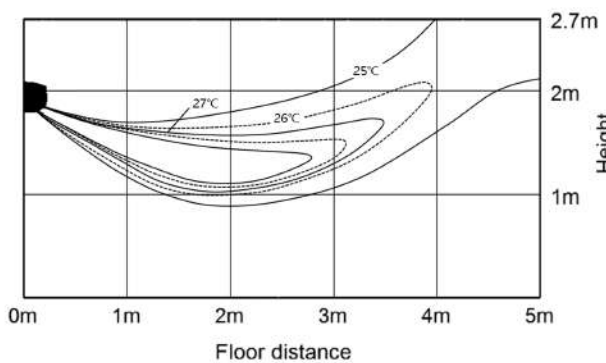

# 8. Temperature and air flow distribution

## Wall mounted

### AM022DNVDKG/EU

1) Cooling air velocity distribution

Discharge angle : 20°

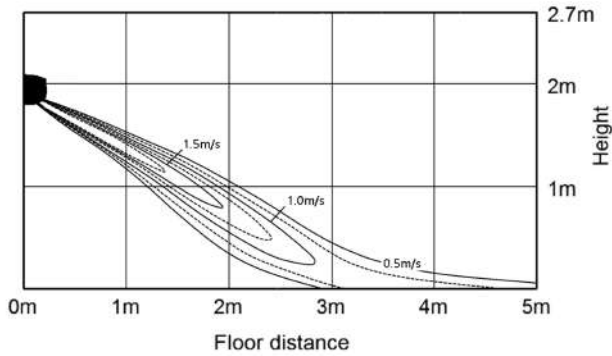

2) Cooling temperature distribution

Discharge angle : 20°

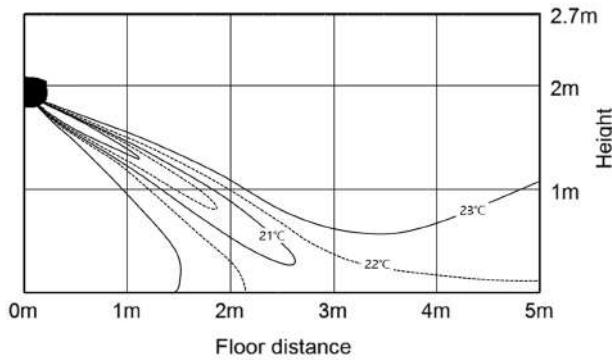

3) Heating air velocity distribution

Discharge angle : 30°

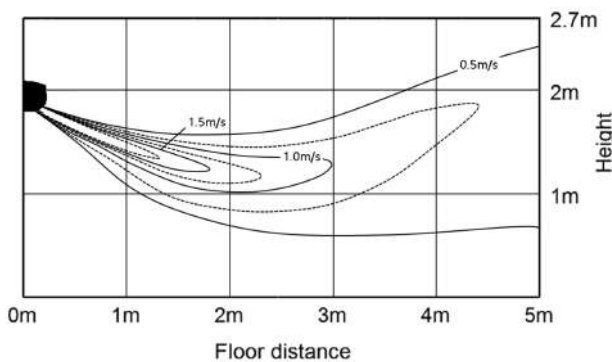

4) Heating temperature distribution

Discharge angle : 30°

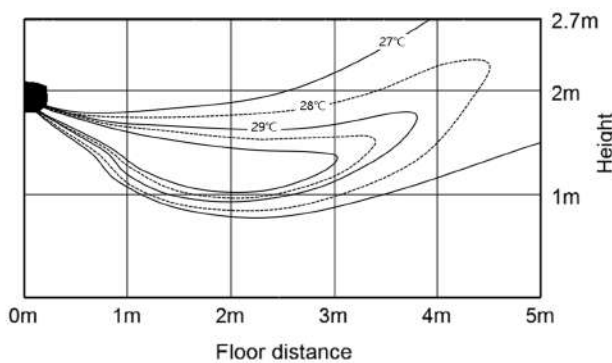

# 8. Temperature and air flow distribution

## Wall mounted

### AM028DNVDKG/EU

1) Cooling air velocity distribution

Discharge angle : 20°

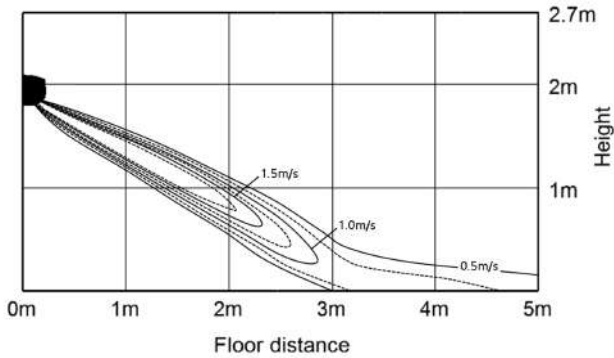

2) Cooling temperature distribution

Discharge angle : 20°

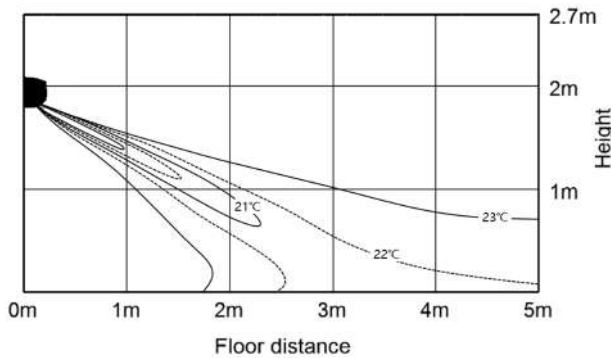

3) Heating air velocity distribution

Discharge angle : 30°

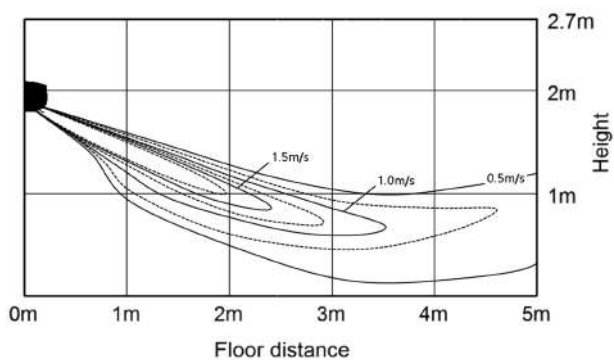

4) Heating temperature distribution

Discharge angle : 30°

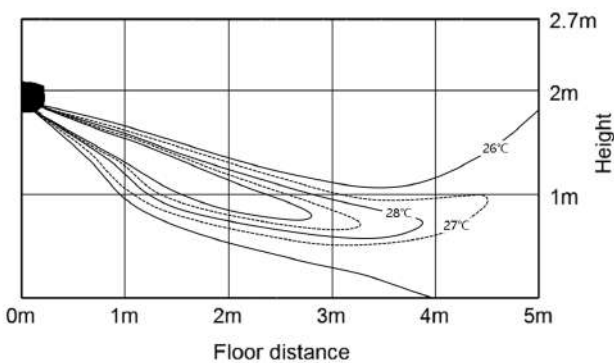

# 8. Temperature and air flow distribution

## Wall mounted

### AM036DNVDKG/EU

1) Cooling air velocity distribution

Discharge angle : 20°

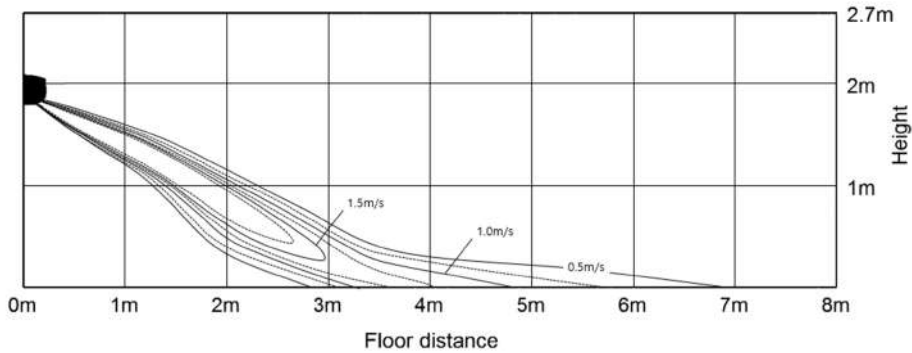

2) Cooling temperature distribution

Discharge angle : 20°

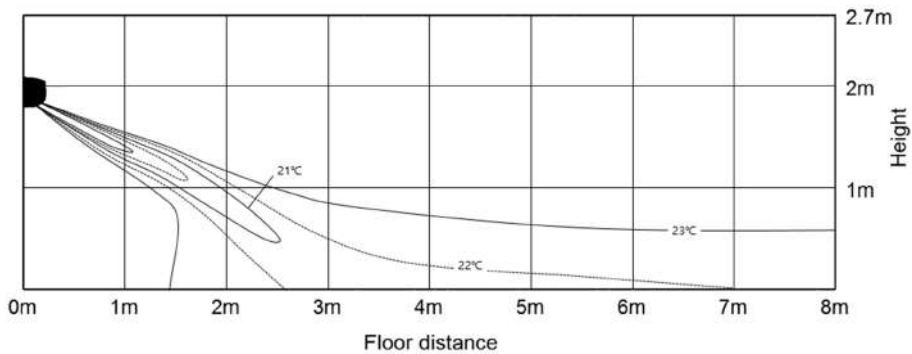

3) Heating air velocity distribution

Discharge angle : 30°

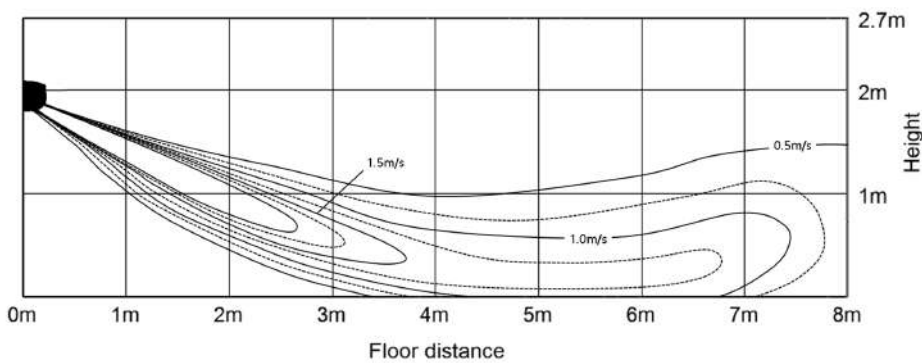

4) Heating temperature distribution

Discharge angle : 30°

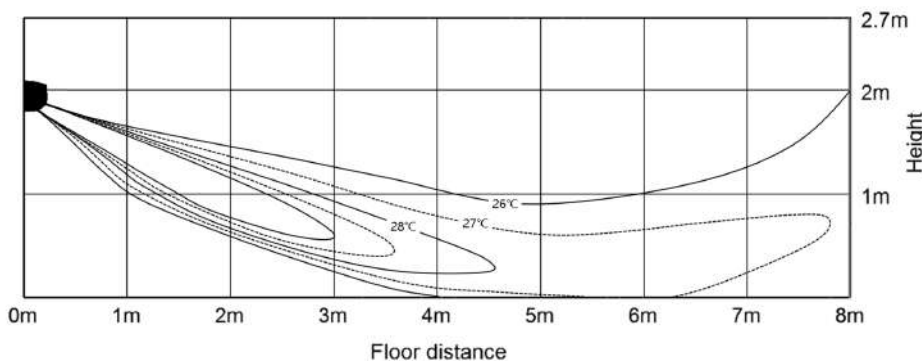

# 8. Temperature and air flow distribution

## Wall mounted

### AM045DNVDKG/EU

1) Cooling air velocity distribution

Discharge angle : 20°

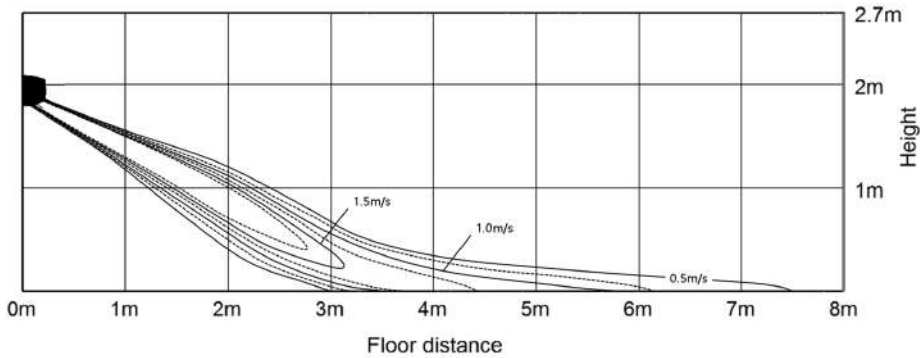

2) Cooling temperature distribution

Discharge angle : 20°

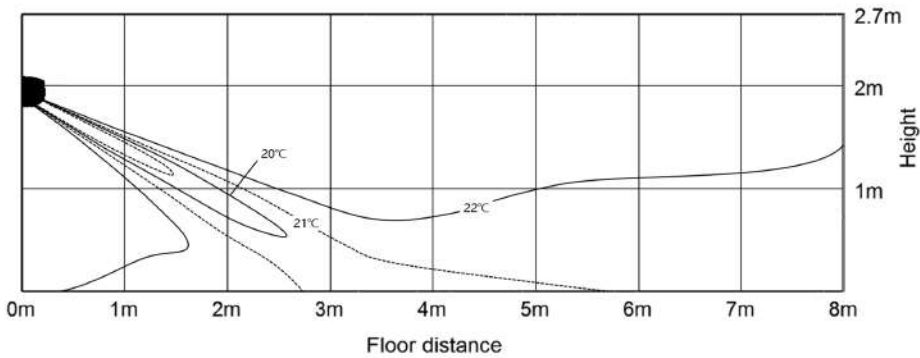

3) Heating air velocity distribution

Discharge angle : 30°

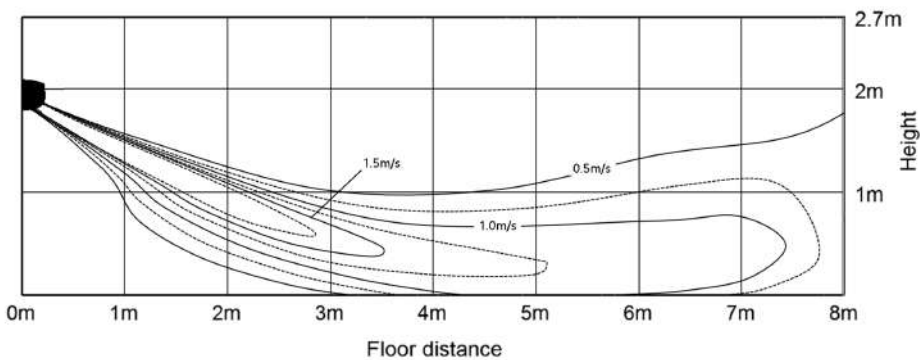

4) Heating temperature distribution

Discharge angle : 30°

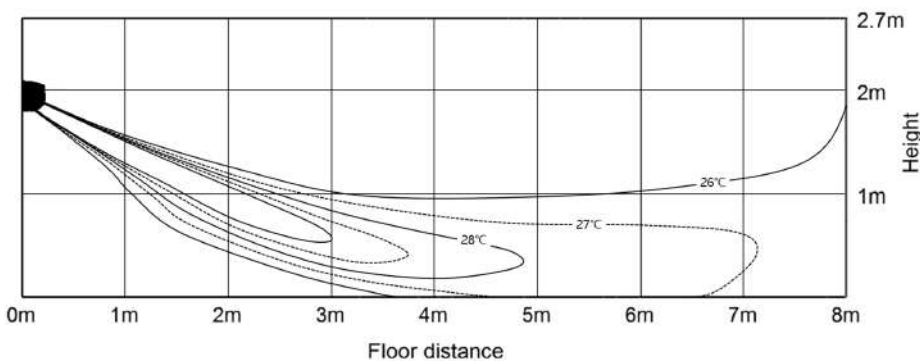

# 8. Temperature and air flow distribution

## Wall mounted

### AM056DNVDKG/EU

1) Cooling air velocity distribution

Discharge angle : 20°

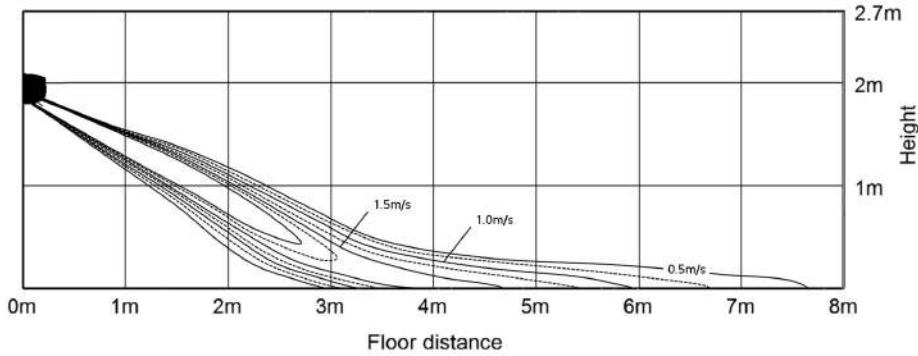

2) Cooling temperature distribution

Discharge angle : 20°

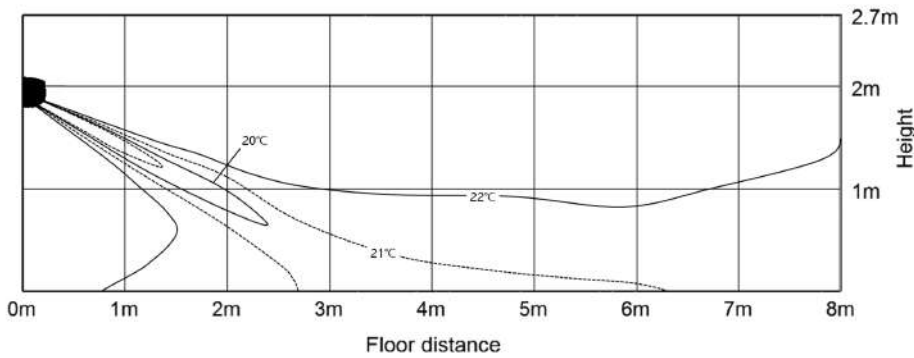

3) Heating air velocity distribution

Discharge angle : 30°

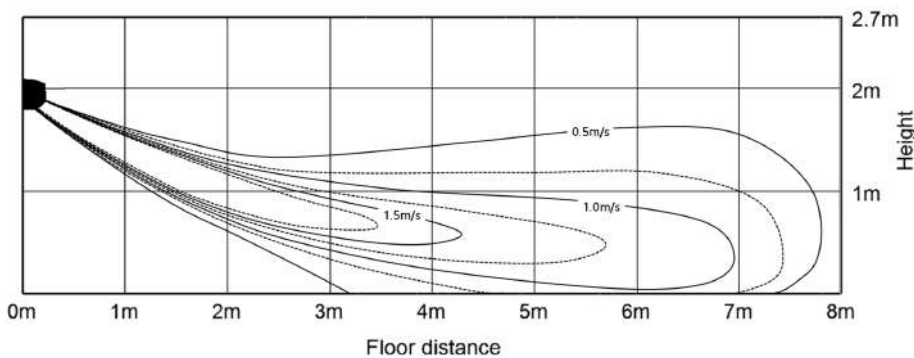

4) Heating temperature distribution

Discharge angle : 30°

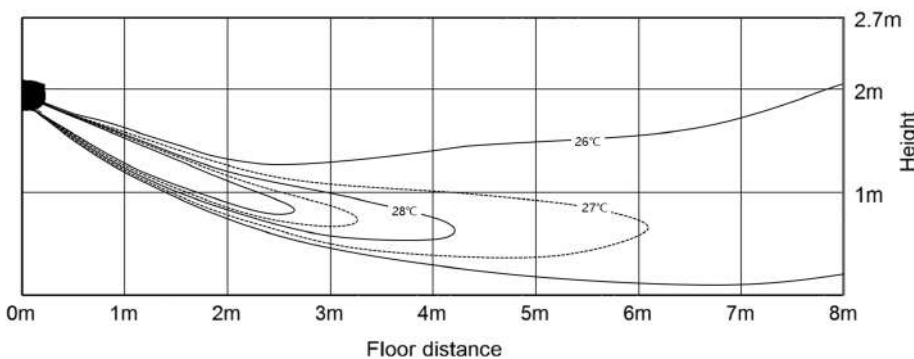

# 8. Temperature and air flow distribution

## Wall mounted

### AM071DNVDKG/EU

1) Cooling air velocity distribution

Discharge angle : 20°

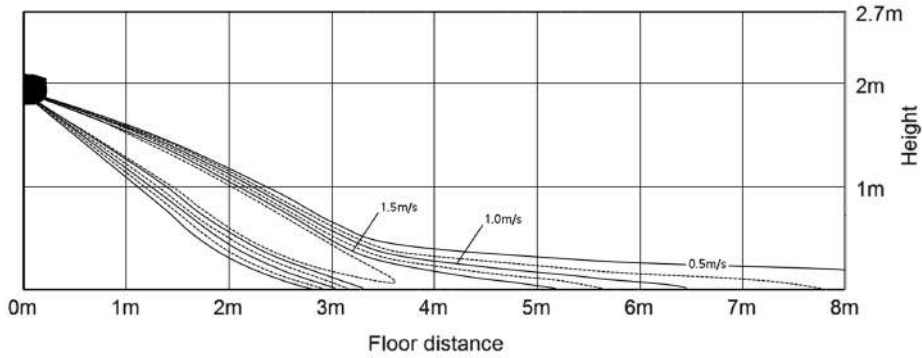

2) Cooling temperature distribution

Discharge angle : 20°

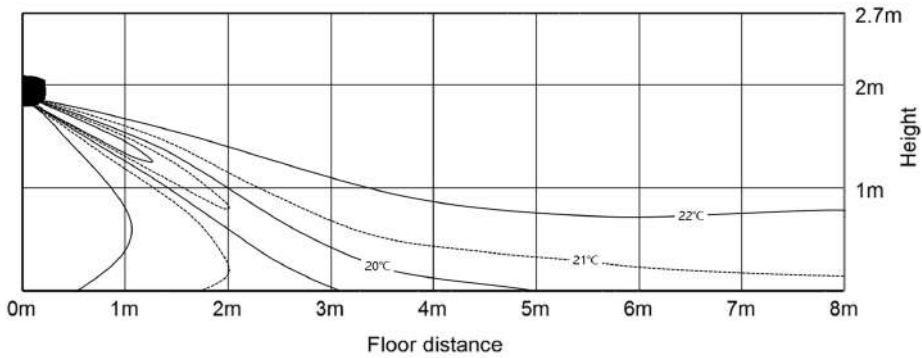

3) Heating air velocity distribution

Discharge angle : 30°

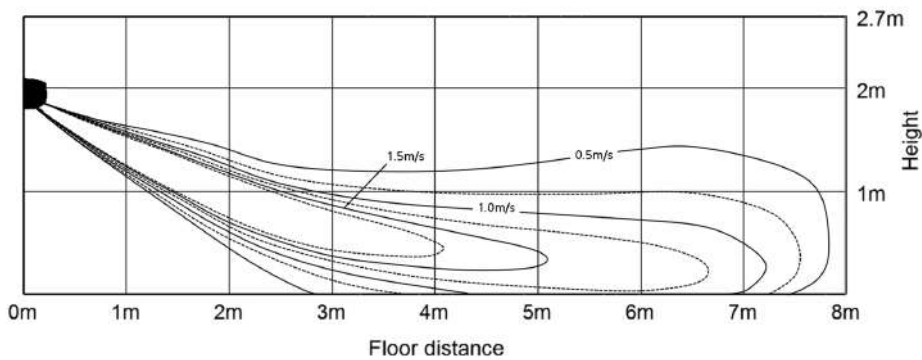

4) Heating temperature distribution

Discharge angle : 30°

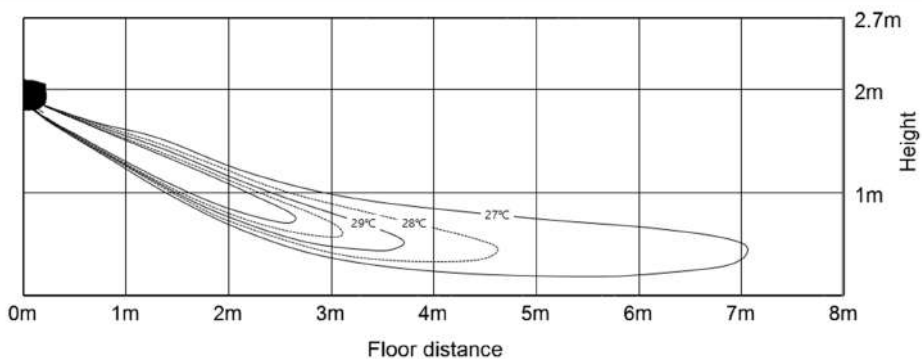

# 8. Temperature and air flow distribution

## Wall mounted

### AM082DNVDKG/EU

1) Cooling air velocity distribution

Discharge angle : 20°

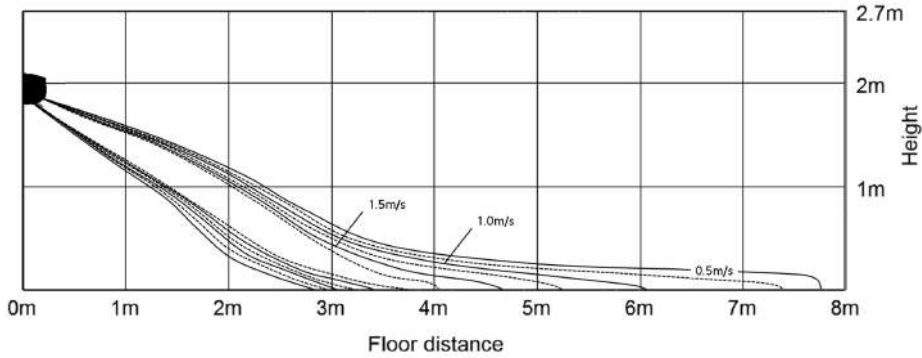

2) Cooling temperature distribution

Discharge angle : 20°

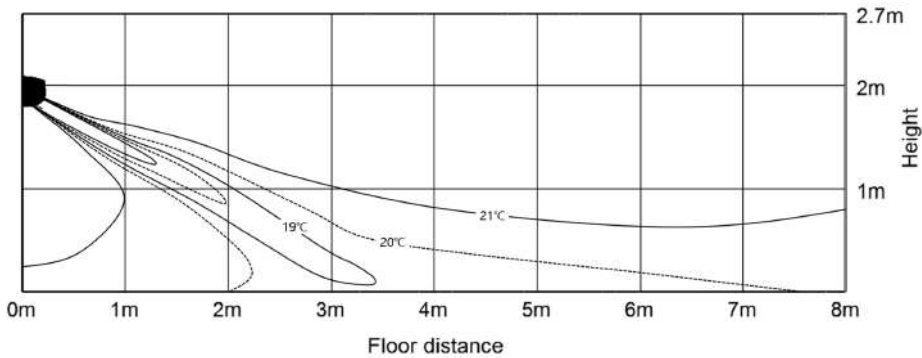

3) Heating air velocity distribution

Discharge angle : 30°

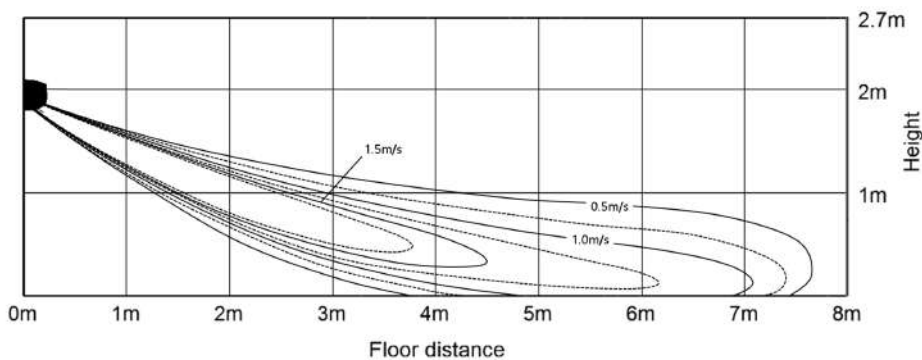

4) Heating temperature distribution

Discharge angle : 30°

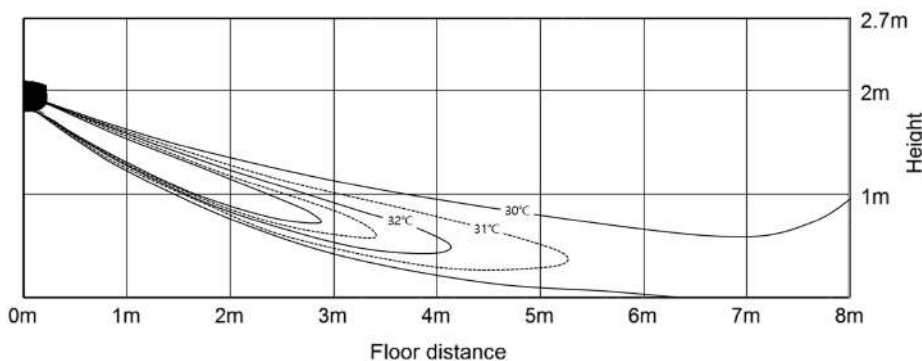

# 8. Temperature and air flow distribution

Wall mounted

AM093DNQDKG/EU

1) Cooling air velocity distribution

Discharge angle : 27°

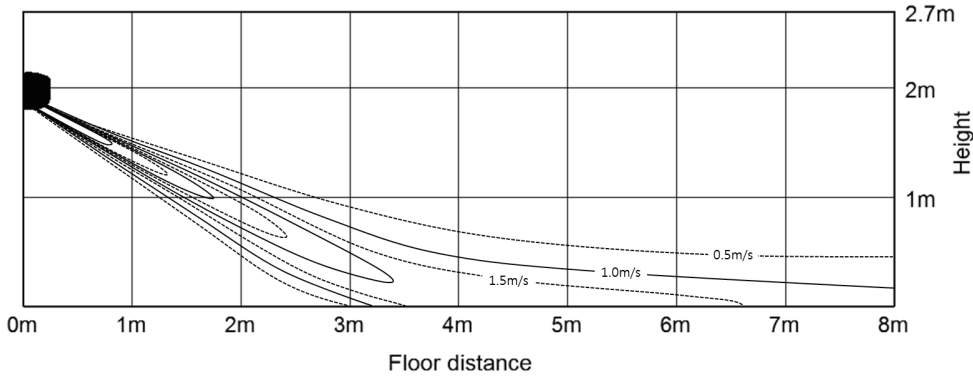

2) Cooling temperature distribution

Discharge angle : 27°

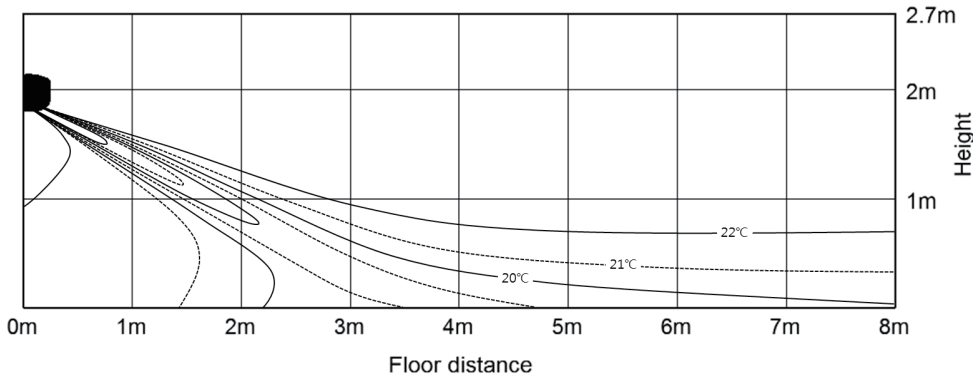

3) Heating air velocity distribution

Discharge angle : 27°

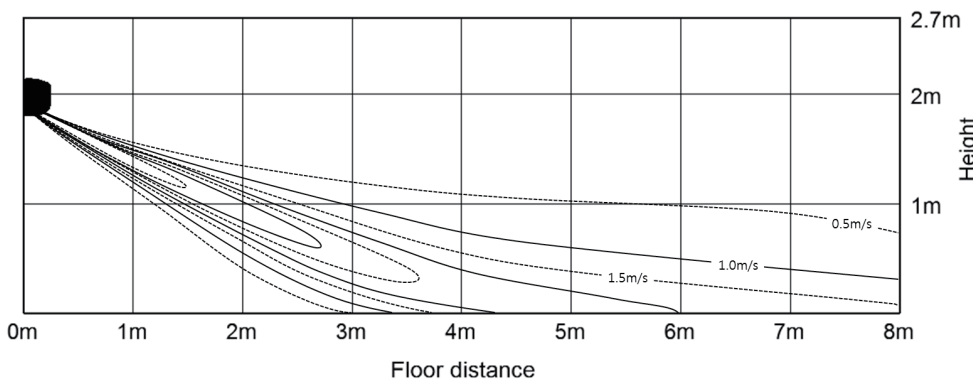

4) Heating temperature distribution

Discharge angle : 27°

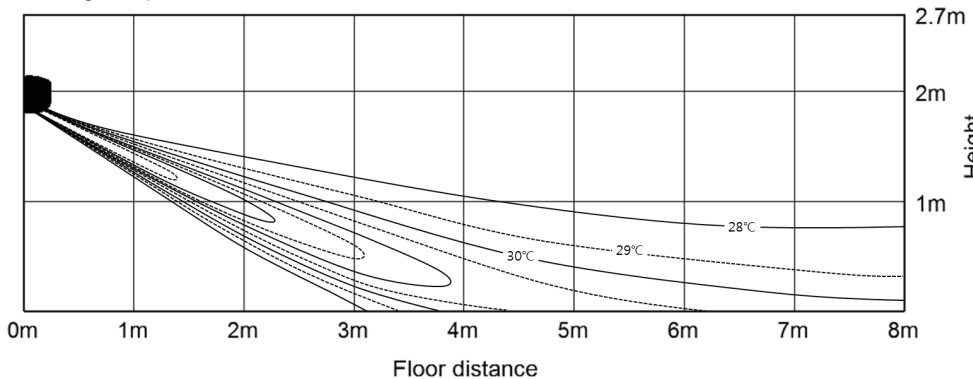

# 9. Piping Diagram

Wall mounted

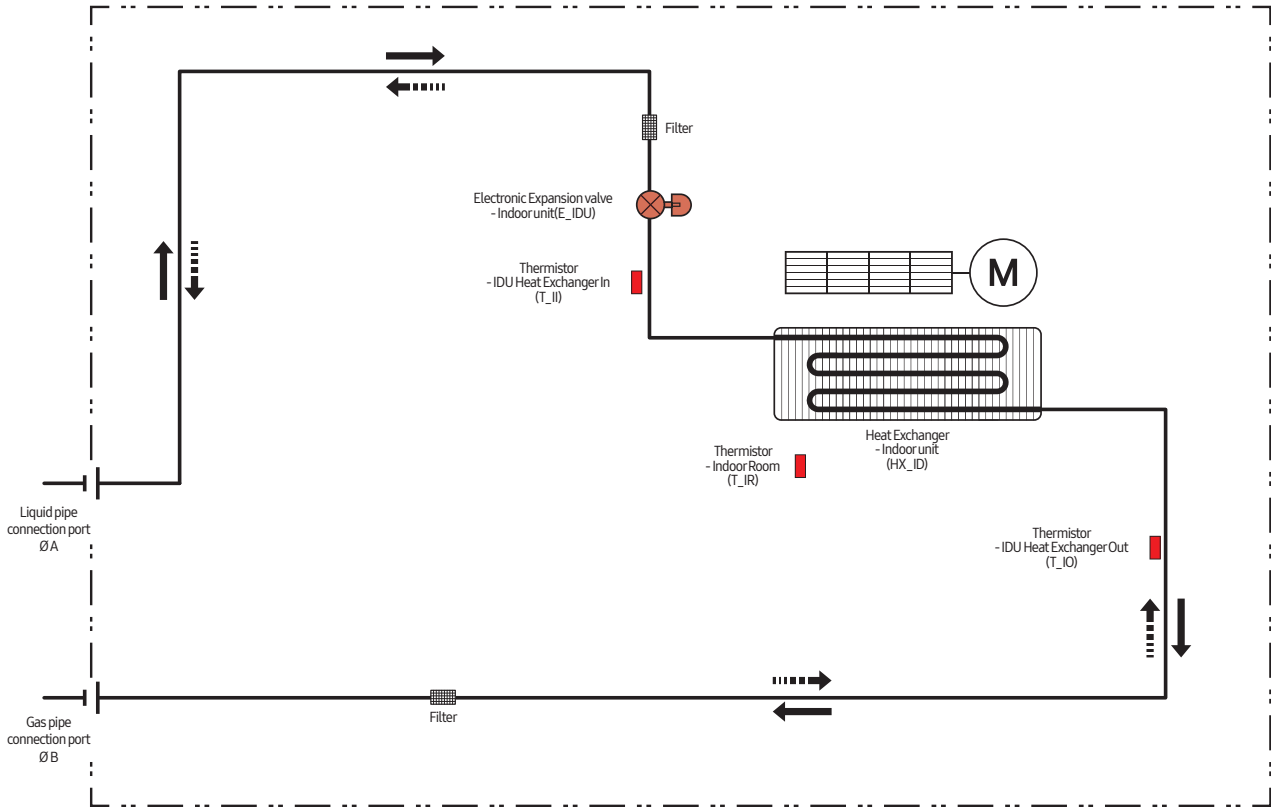

Refrigerant flow	
Cooling	Heating

# Ceiling



---

1. Specification	280
2. Summary Table	281
3. Capacity Table	282
4. Dimensional Drawing	283
5. Center of Gravity	286
6. Electrical Wiring Diagram	289
7. Sound Data	291
8. Temperature and air flow distribution	293
9. Piping Diagram	297

---

# Line-up

## Ceiling

Capacity (kW)			
5.6	7.1	11.2	14.0
			

# 1. Specification

## Ceiling

Model Name				AM056DNCDKG/EU	AM071DNCDKG/EU	AM112DNCDKG/EU	AM140DNCDKG/EU
Power Supply			Φ, #, V, Hz	1,2,220-240,50/60	1,2,220-240,50/60	1,2,220-240,50/60	1,2,220-240,50/60
Performance	Capacity	Cooling	kW	5.6	7.1	11.2	14.0
			Btu/h	19,100	24,200	38200	47800
		Heating	kW	6.3	8.0	12.5	16.0
			Btu/h	21,500	27,300	42700	54600
Power	Power Input	Cooling	W	50.0	51.0	92.0	160.0
		Heating		50.0	51.0	80.0	160.0
	Current Input	Cooling	A	0.43	0.47	0.94	1.45
		Heating		0.43	0.47	0.83	1.45
	Current	MCA	A	0.60	0.60	3.00	3.30
		MFA		15	15	15	15
Heat exchanger	Type		-	Fin & Tube	Fin & Tube	Fin & Tube	Fin & Tube
	Material	Fin	-	Al	Al	Al	Al
		Tube	-	Cu	Cu	Cu	Cu
	Fin Treatment		-	NEO SILICA	NEO SILICA	NEO SILICA	NEO SILICA
Fan	Type	Type	-	Sirocco Fan	Sirocco Fan	Sirocco Fan	Sirocco Fan
	Quantity		ea	2	3	3	3
	Air Flow Rate	H/M/L	CMM	12.6 / 11.3 / 10.0	18.4 / 16.4 / 14.3	29.3 / 23.9 / 18.5	36.4 / 30.8 / 26
			l/s	233 / 217 / 200	300 / 275 / 250	488 / 398 / 308	607 / 513 / 433
Fan Motor	Model		-	BLDC Motor	BLDC Motor	BLDC Motor	BLDC Motor
	Output x n		W	40	153	153	244
Piping Connections	Liquid Pipe	Type	-	Flare connection	Flare connection	Flare connection	Flare connection
		Φ,mm	6.35	9.52	9.52	9.52	
		Φ, inch	1/4	3/8	3/8	3/8	
	Gas Pipe	Type	-	Flare connection	Flare connection	Flare connection	Flare connection
		Φ,mm	12.70	15.88	15.88	15.88	
		Φ, inch	1/2	5/8	5/8	5/8	
	Heat insulation		-	Both liquid & gas pipes	Both liquid & gas pipes	Both liquid & gas pipes	Both liquid & gas pipes
Drain Pipe		Φ,mm	ID 18 hose	VP25 (OD 32,ID 25)	VP25 (OD 32,ID 25)	VP25 (OD 32,ID 25)	
Wiring connections	Communication	Min.	mm <sup>2</sup>	0.75	0.75	0.75	0.75
		Remark	-	F1, F2	F1, F2	F1, F2	F1, F2
Refrigerant	Type		-	R32	R32	R32	R32
	Electronic Expansion Valve		-	EEV INCLUDED	EEV INCLUDED	EEV INCLUDED	EEV INCLUDED
Sound Level	Sound Pressure Level	H/M/L	dB(A)	41 / 39 / 36	37 / 35 / 33	45 / 41 / 37	46 / 43 / 38
	Sound Power Level	Cooling		60	56	61	63
Dimensions	Net Weight		kg	20.8	34.0	34.0	42.0
	Shipping Weight		kg	26.2	39.4	39.4	48.5
	Net Dimensions (W×H×D)		mm	1,000 x 650 x 200	1,350 x 235 x 675	1,350 x 235 x 675	1,650 x 235 x 675
	Shipping Dimensions (W×H×D)		mm	1,080 x 730 x 300	1,439 x 758 x 321	1,439 x 758 x 321	1,739 x 758 x 321
Drain Pump	Drain Pump		-	-	-	-	-
	Max. lifting Height / Displacement		mm / Liter/h	-	-	-	-

### NOTE

- Specification may be subject to change without prior notice.
  - 1) Capacities are based on (Equivalent refrigerant piping 7.5m, Level differences 0m);
    - Cooling : Indoor temperature 27°C DB, 19°C WB / Outdoor temperature 35°C DB, 24°C WB
    - Heating : Indoor temperature 20°C DB, 15°C WB / Outdoor temperature 7°C DB, 6°C WB
  - 2) Sound level was acquired in an anechoic room. Thus actual noise level may be different depending on the installation conditions.
  - 3) These products contain R32 (GWP=675) which is fluorinated greenhouse gas.
  - 4) Select wire size based on the value of MCA

## 2. Summary Table

### Ceiling

#### Performance Characteristics

Model Code	Net Weight (kg)	Fan Speed	Nominal Capacity (kW)			Airflow (CMM)	Sound Pressure (dBA)	Sound Power (dBA)
			Cooling	Sensible	Heating			
AM056DNCDKG/EU	20.8	High	5.6	3.9	6.3	12.6	41	60
		Mid	5.1	3.6	6.0	11.3	39	-
		Low	4.6	3.2	5.6	10.0	36	-
AM071DNCDKG/EU	34.0	High	7.1	5.0	8.0	18.4	37	56
		Mid	6.4	4.5	7.6	16.4	35	-
		Low	5.7	4.0	7.1	14.3	33	-
AM112DNCDKG/EU	34.0	High	11.2	7.9	12.5	29.3	45	61
		Mid	9.4	6.6	11.3	23.9	41	-
		Low	7.3	5.1	9.9	18.5	37	-
AM140DNCDKG/EU	42.0	High	14.0	9.6	16.0	36.4	46	63
		Mid	12.1	8.3	14.7	30.8	43	-
		Low	10.3	7.1	13.5	26.0	38	-

#### NOTE

- Sound data is based on cooling operation.

#### Electric Characteristics

Indoor Unit	Power Supply (Ø, #, V, Hz)	Power Input (W)	Current Input (A)	MCA (A)	MFA (A)	FLA (A)
AM056DNCDKG/EU	1,2,220~240,50/60	50.0	0.43	0.60	15	0.48
AM071DNCDKG/EU	1,2,220~240,50/60	51.0	0.47	0.60	15	0.48
AM112DNCDKG/EU	1,2,220~240,50/60	92.0	0.94	3.00	15	2.40
AM140DNCDKG/EU	1,2,220~240,50/60	160.0	1.45	3.30	15	2.64

#### NOTE

- MCA : Minimum circuit amperes
- MFA : Maximum fuse amperes
- Select wire size based on the value of MCA

# 3. Capacity Table

## Ceiling

### Cooling

TC : Total Capacity, SHC : Sensible Heat Capacity

Capacity Index	Outdoor Air Temp. (°C, DB)	Indoor temperature													
		20(°C, DB)		23(°C, DB)		26(°C, DB)		27(°C, DB)		28(°C, DB)		30(°C, DB)		32(°C, DB)	
		14(°C, WB)		16(°C, WB)		18(°C, WB)		19(°C, WB)		20(°C, WB)		22(°C, WB)		24(°C, WB)	
		TC	SHC	TC	SHC	TC	SHC	TC	SHC	TC	SHC	TC	SHC	TC	SHC
056	35	3.9	3.2	4.6	3.5	5.3	3.9	5.6	3.9	5.8	3.9	6.2	3.8	6.6	3.6
071	35	4.9	4.0	5.8	4.5	6.7	4.8	7.1	5.0	7.4	5.0	7.9	5.0	8.4	4.8
112	35	7.7	6.3	9.1	7.0	10.5	7.8	11.2	7.9	11.6	7.9	12.4	7.9	13.2	7.7
140	35	9.7	7.7	11.4	8.5	13.1	9.4	14.0	9.6	14.5	9.6	15.5	9.5	16.5	9.4

### Heating

TC : Total Capacity (kW)

Capacity Index	Outdoor Air Temp. (°C)		Indoor temperature (°C, DB)				
			16(°C, DB)	18(°C, DB)	20(°C, DB)	22(°C, DB)	24(°C, DB)
	DB	WB	TC	TC	TC	TC	TC
056	7.0	6.0	kW	kW	kW	kW	kW
071	7.0	6.0	6.5	6.4	6.3	5.8	5.3
071	7.0	6.0	8.2	8.1	8.0	7.4	6.8
112	7.0	6.0	12.9	12.7	12.5	11.5	10.6
140	7.0	6.0	16.5	16.2	16.0	14.8	13.5

### NOTE

- The performance table shows the average value of each conditions.

# 4. Dimensional Drawing

## Ceiling

AM056DNCDKG/EU

Units : mm [inches]

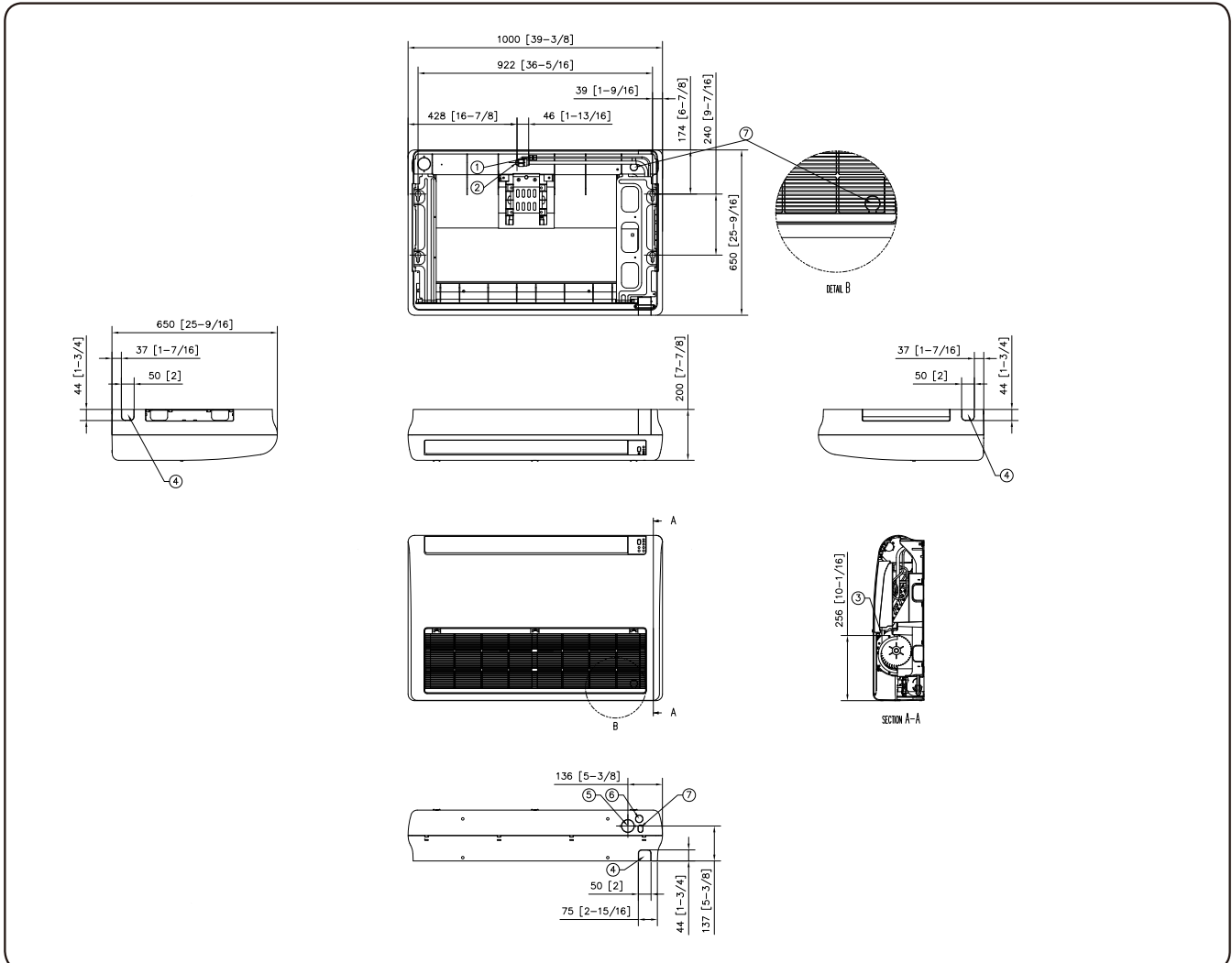

No.	Name	Description
1	Refrigerant liquid pipe	Φ6.35(1/4)
2	Refrigerant gas pipe	Φ12.7(1/2)
3	Condensate drain	ID18mm [11/16inch] Hose
4	Knockout hole for piping	
5	Knockout hole for air intake	Φ50 [2]
6	Knockout hole for drain pipe	
7	Knockout hole for wiring	

### NOTE

- As for suspension bolt, please use M8 ~ M10. (Procured at local site)

# 4. Dimensional Drawing

## Ceiling

AM071DNCDKG/EU, AM112DNCDKG/EU

Units : mm [inches]

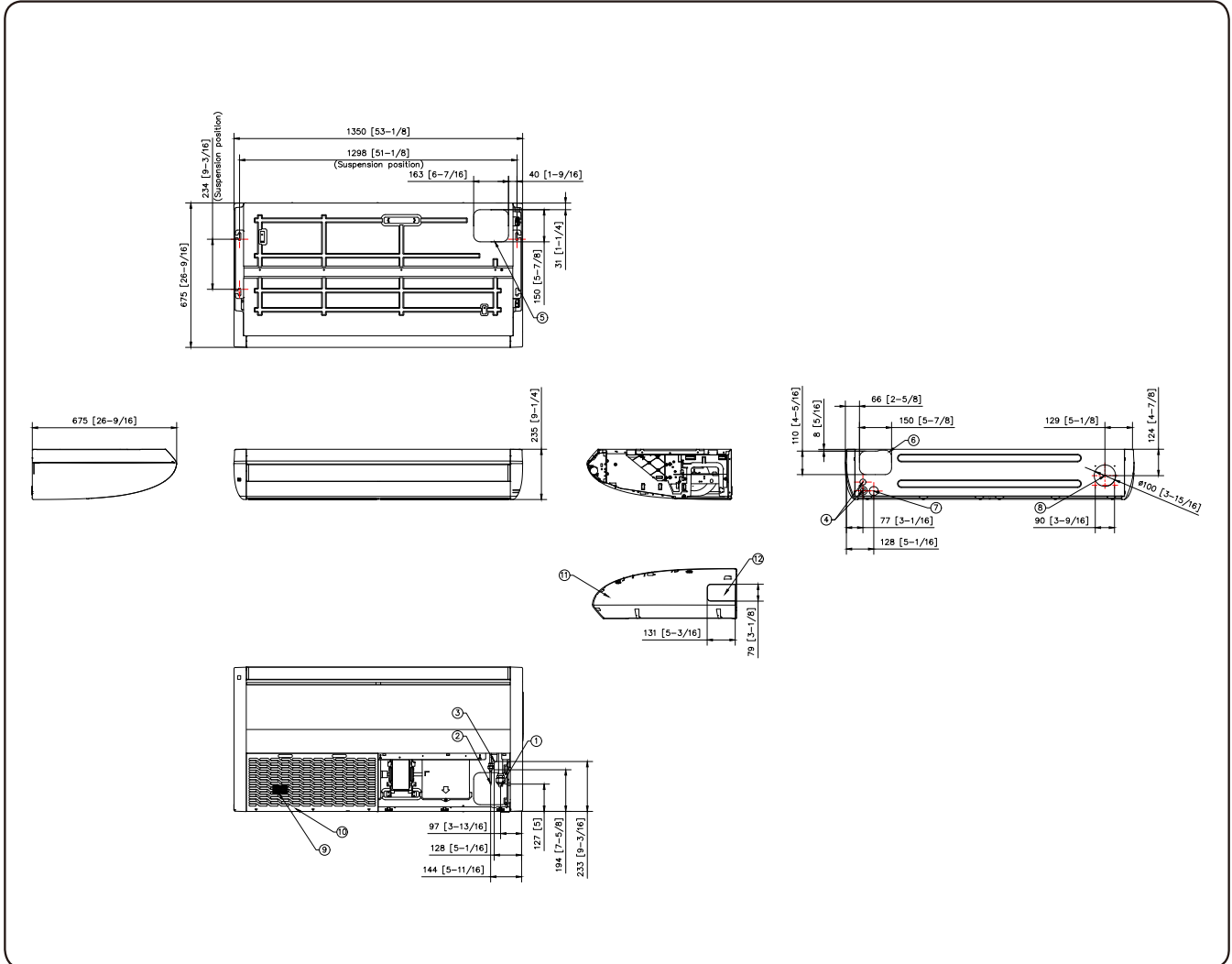

No.	Name	Description
1	Refrigerant gas pipe	Φ15.88 (5/8)
2	Refrigerant liquid pipe	Φ9.52 (3/8)
3	Condensate drain	VP25 (OD 25, ID 20)
4	Conduit hole	Φ28(1-1/8)
5	Knockout hole for upper piping arrangement	
6	Knockout hole for rear piping arrangement	
7	Knockout hole for drain pipe arrangement	
8	Knockout hole for fresh air intake	Φ42(Φ1-5/16)
9	Air filter	
10	Air suction grille	
11	Cover side	
12	Knockout hole for side piping arrangement	

### NOTE

- As for suspension bolt, please use M8 ~ M10.  
(Procured at local site)

# 4. Dimensional Drawing

## Ceiling

AM140DNCDKG/EU

Units : mm [inches]

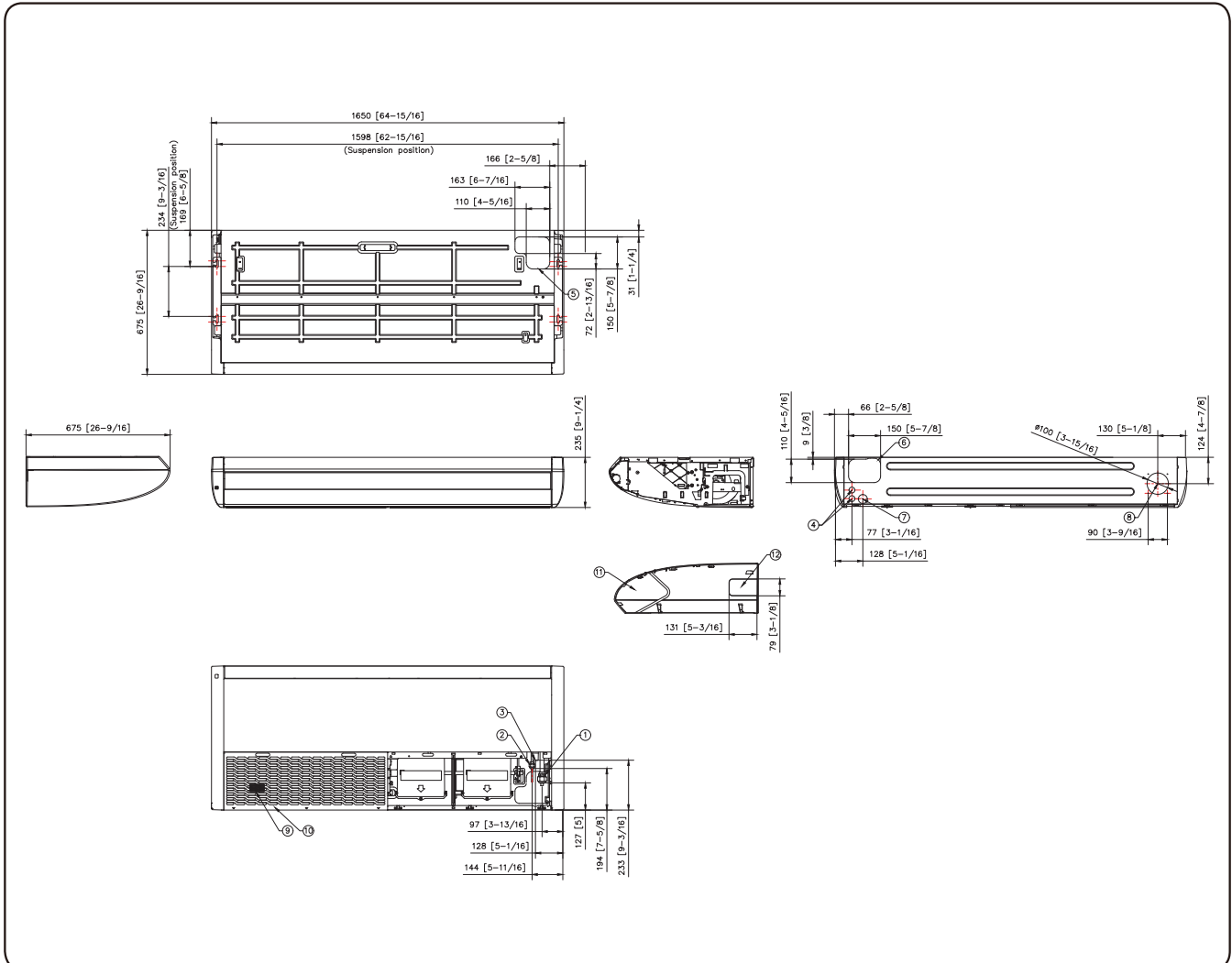

No.	Name	Description
1	Gas pipe connection	Φ15.88[5/8]
2	Liquid pipe connection	Φ9.52[3/8]
3	Drain pipe connection	VP-25(OD32, ID25)
4	Conduit hole	Φ28[1-1/8]
5	Knockout hole for upper piping arrangement	-
6	Knockout hole for rear piping arrangement	-
7	Knockout hole for drain pipe arrangement	-
8	Knockout hole for fresh air intake	Φ42[1-5/16]
9	Air filter	-
10	Air suction grille	-
11	Cover side	-
12	Knockout hole for side piping arrangement	-

### NOTE

- As for suspension bolt, please use M8 ~ M10.  
(Procured at local site)

# 5. Center of Gravity

Ceiling

AM056DNCDKG/EU

Units : mm [inches]

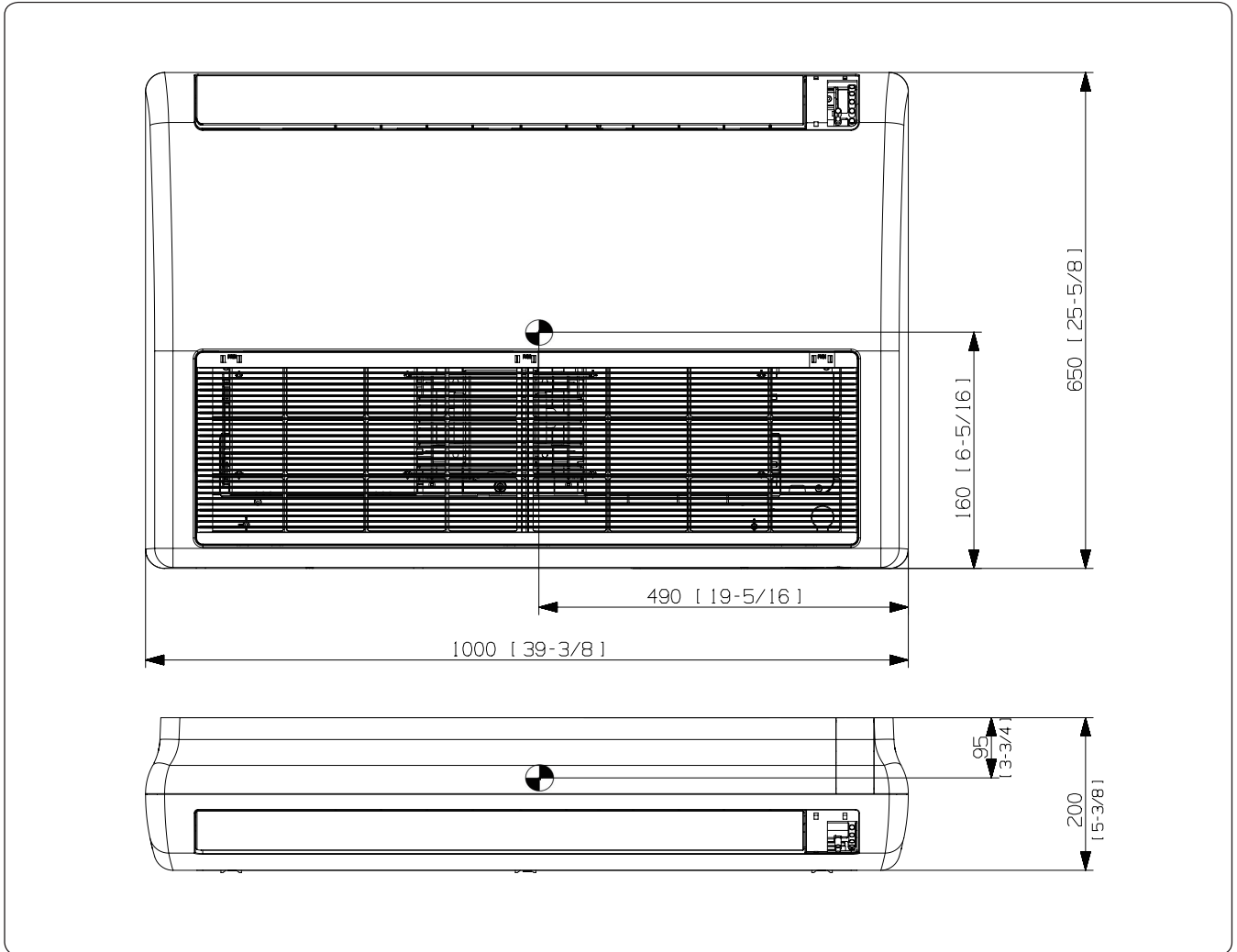

# 5. Center of Gravity

Ceiling

AM071DNCDKG/EU, AM112DNCDKG/EU

Units : mm [inches]

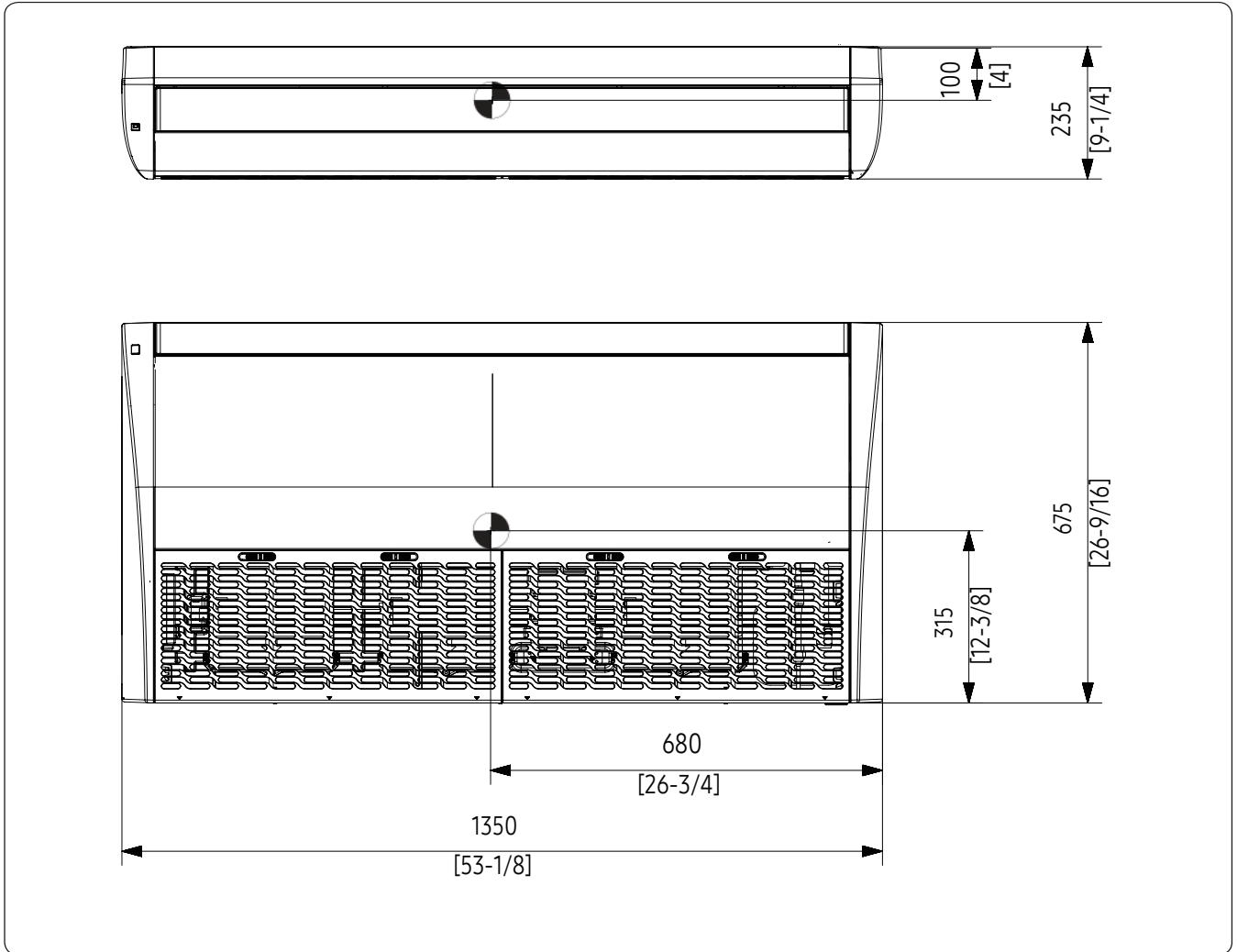

# 5. Center of Gravity

Ceiling

AM140DNCDKG/EU

Units : mm [inches]

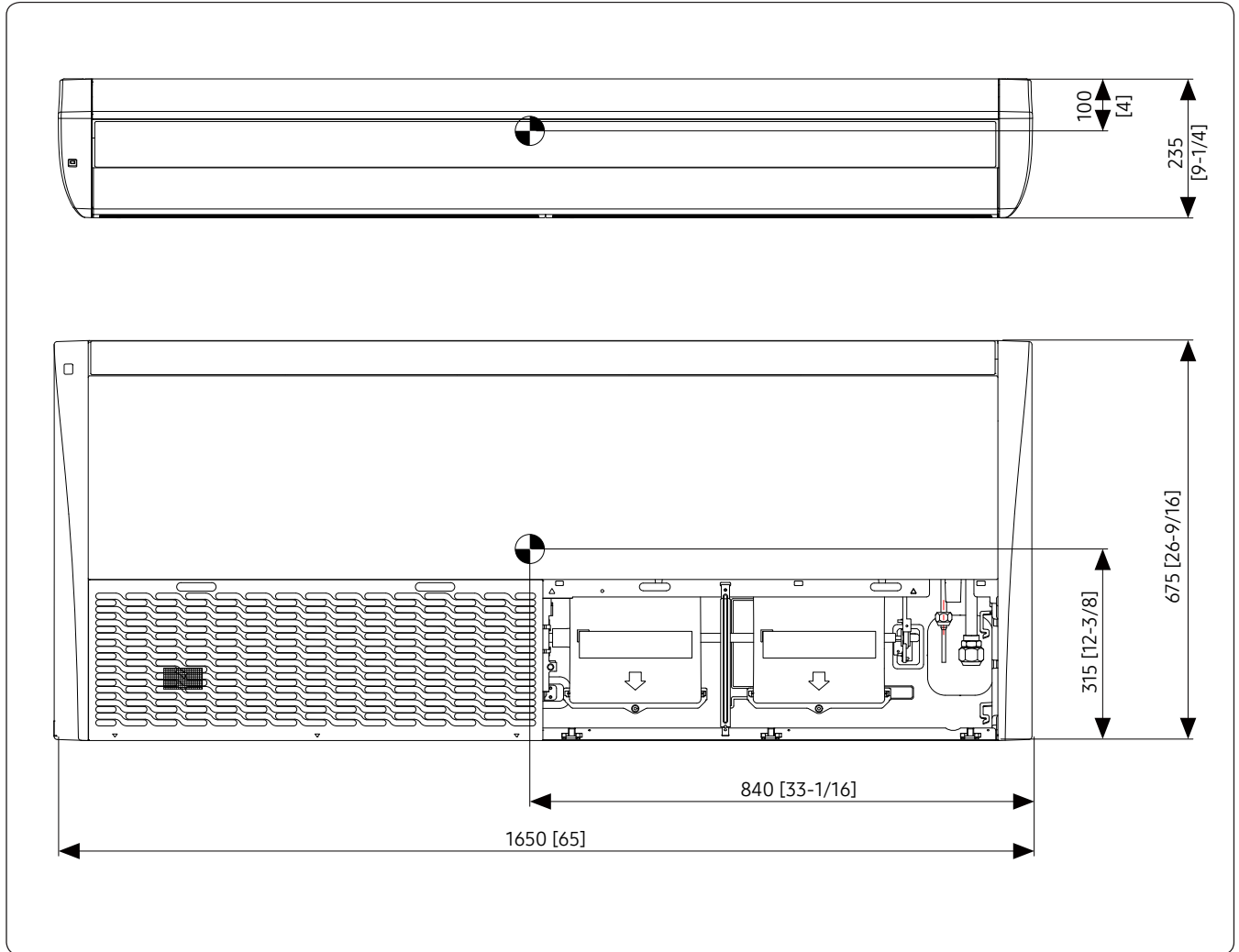

# 6. Electrical Wiring Diagram

## Ceiling

AM056DNCDKG/EU, AM071DNCDKG/EU

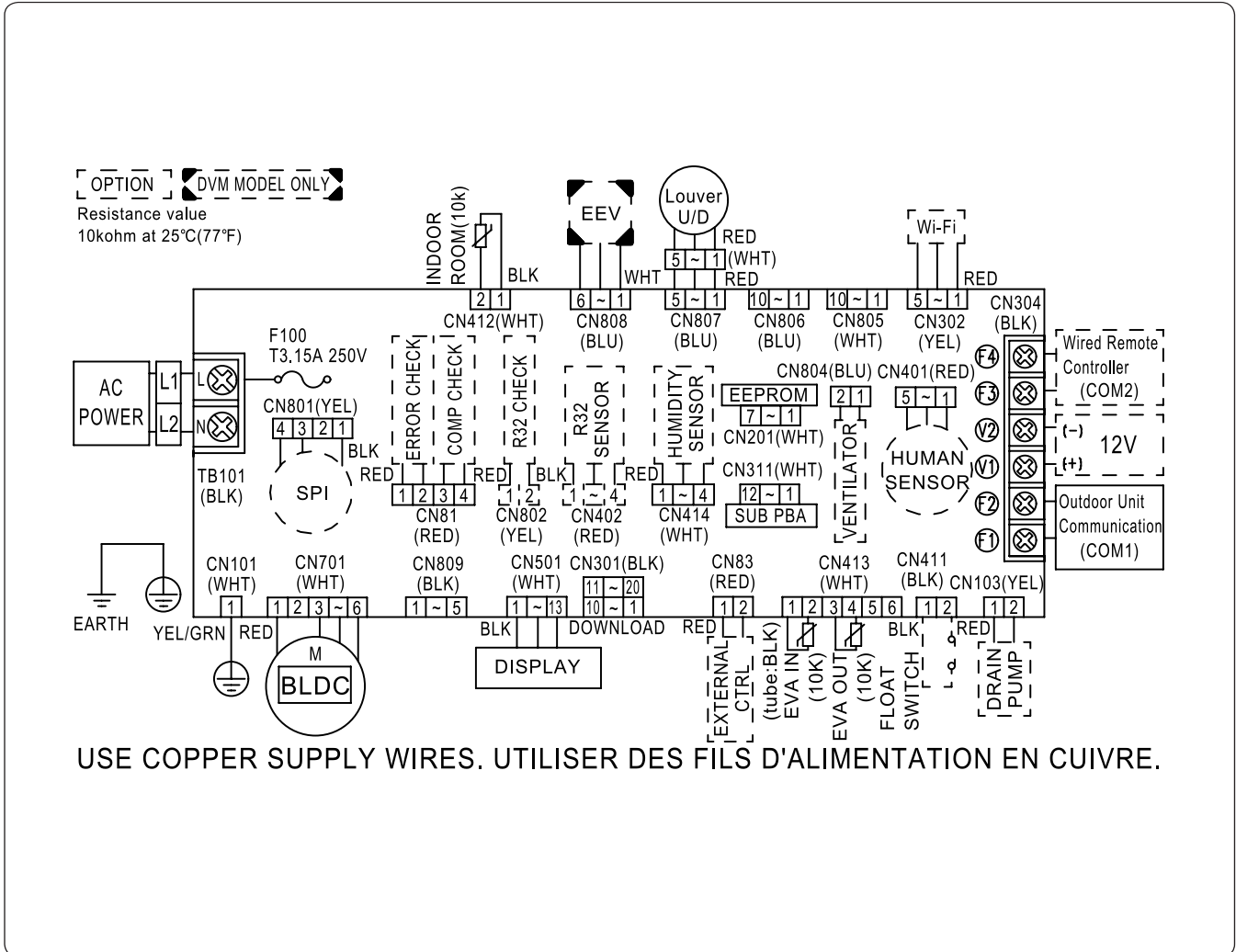

F100	FUSE	EEV	Electronic Expansion Valve	ROOM(10K)	Thermistor ROOM OUT(10K)
M-BLDC	BLDC Motor	EXT_CONTROL	EXTERNAL_CONTROL	EVA-IN(10K)	Thermistor EVA IN(10K)
				EVA-OUT(10K)	Thermistor EVA OUT(10K)

### NOTE

- This wiring diagram applies only to the Indoor unit.
- Symbols show as follow :  
blk: black, red: red, blu: blue, wht: white, yel: yellow, brn: brown, sky: skyblue: grn: green
- For connection wiring indoor-outdoor transmission F1-F2, indoor-wired remote controller transmission F3-F4.
- Protective earth(screw), : connector, : The wire quantity

# 6. Electrical Wiring Diagram

## Ceiling

### AM112DNCDKG/EU, AM140DNCDKG/EU

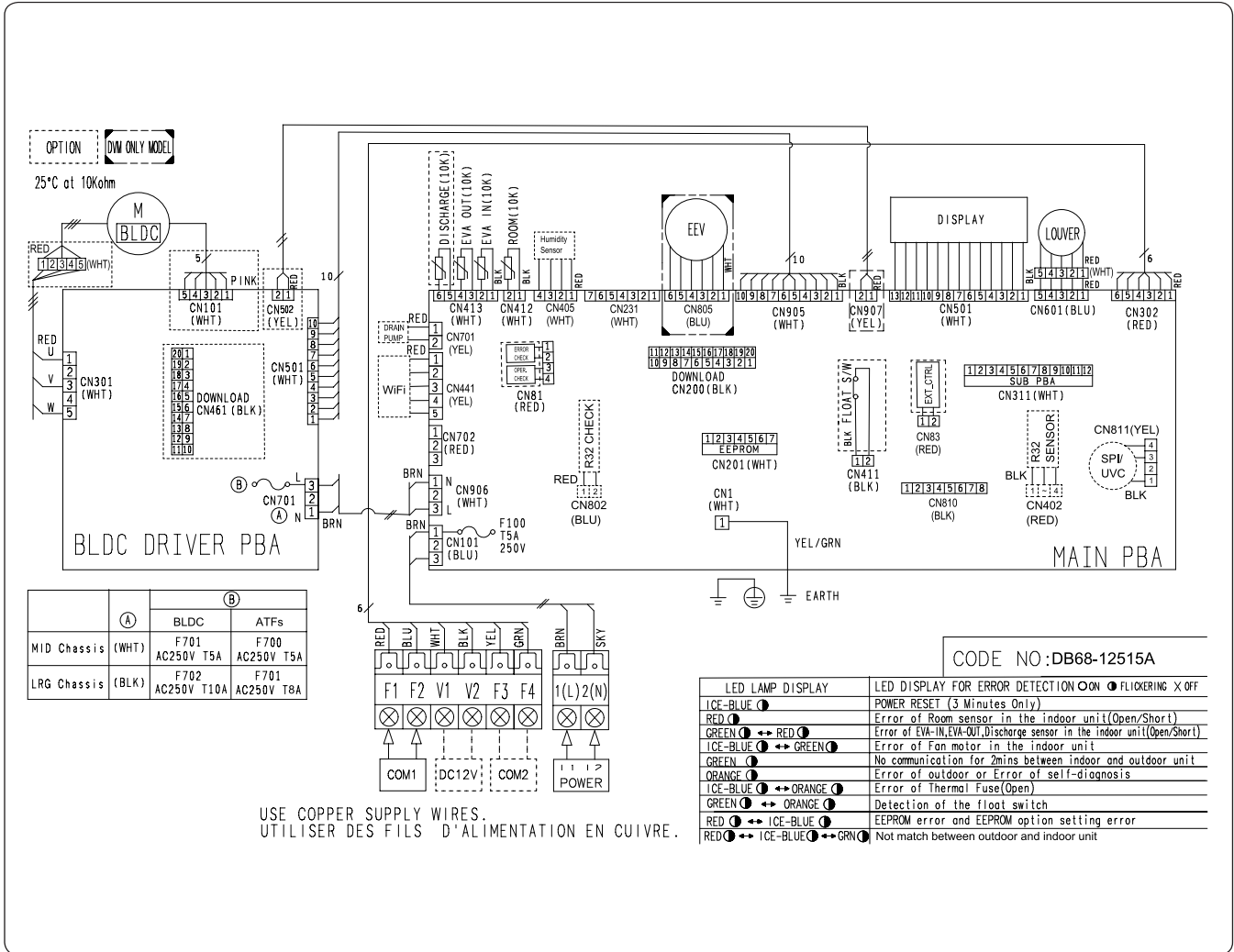

F100	FUSE	EEV	Electronic Expansion Valve	ROOM(10K)	Thermistor ROOM OUT(10K)
M-BLDC	BLDC Motor	EXT_CONTROL	EXTERNAL_CONTROL	EVA-IN(10K)	Thermistor EVA IN(10K)
				EVA-OUT(10K)	Thermistor EVA OUT(10K)

## NOTE

- This wiring diagram applies only to the Indoor unit.
- Symbols show as follow :  
blk: black, red: red, blu: blue, wht: white, yel: yellow, brn: brown, sky: skyblue: grn: green
- For connection wiring indoor-outdoor transmission F1-F2, indoor-wired remote controller transmission F3-F4.
- ⊕ Protective earth(screw), □□□□ : connector,  $\frac{N}{\text{wire}}$  : The wire quantity

# 7. Sound Data

## Ceiling

### Sound Pressure level

Unit: dB(A)

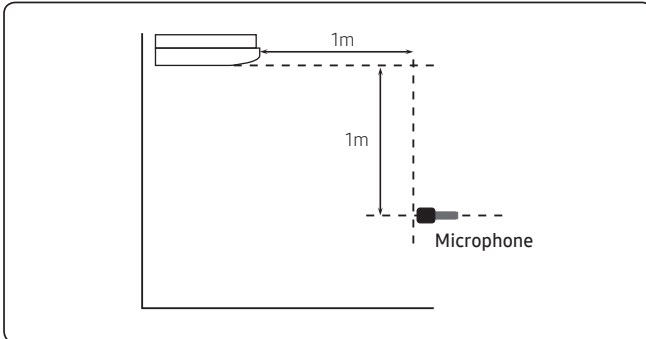

Model	High	Mid	Low
AM056DNCDKG/EU	41	39	36
AM071DNCDKG/EU	37	35	33
AM112DNCDKG/EU	45	41	37
AM140DNCDKG/EU	46	43	38

- NR Curve

1) AM056DNCDKG/EU

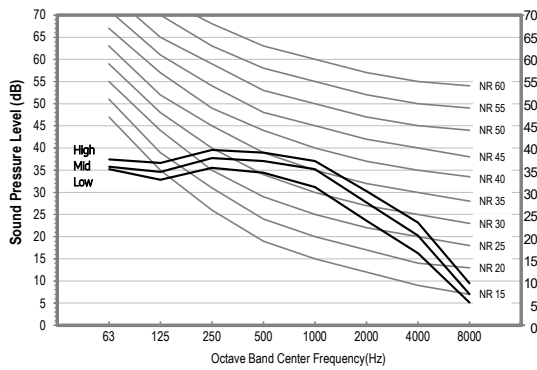

2) AM071DNCDKG/EU

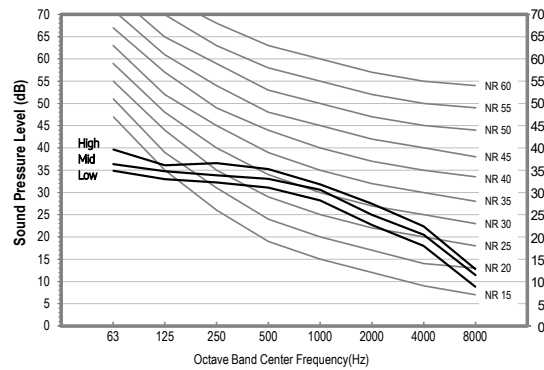

3) AM112DNCDKG/EU

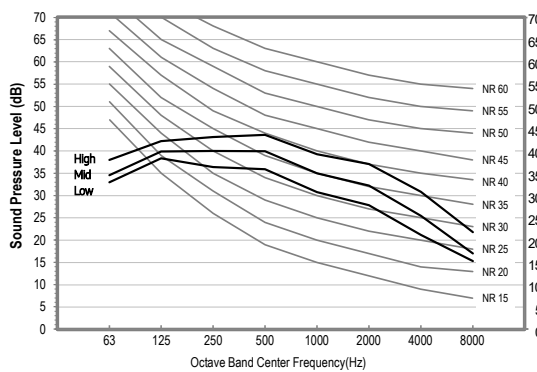

4) AM140DNCDKG/EU

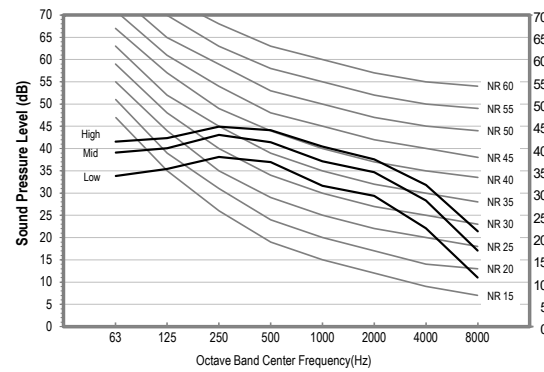

### NOTE

- Specifications may be subject to change without prior notice.
- Sound pressure Level
  - Sound pressure level is obtained in an anechoic room.
  - Sound pressure level is a relative value, depending on the distance and acoustic environment.
  - Sound pressure level may differ depending on operation condition.
  - dBA = A weighted sound pressure level
  - Reference acoustic pressure 0 dB = 20μPa

# 7. Sound Data

## Ceiling

### Sound Power level

#### NOTE

- Specifications may be subject to change without prior notice
  - Sound power level is an absolute value that a sound source generates.
  - dBA = A-weighted sound power level.
  - Reference power : 1pW.
  - Measured according to ISO 3741.

Unit: dB(A)

Model	Power
AM056DNCDKG/EU	60
AM071DNCDKG/EU	56
AM112DNCDKG/EU	61
AM140DNCDKG/EU	63

- NR Curve

1) AM056DNCDKG/EU

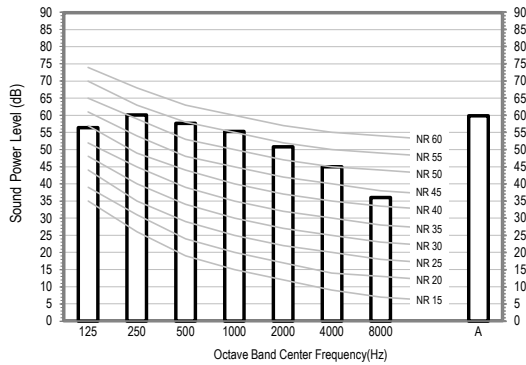

2) AM071DNCDKG/EU

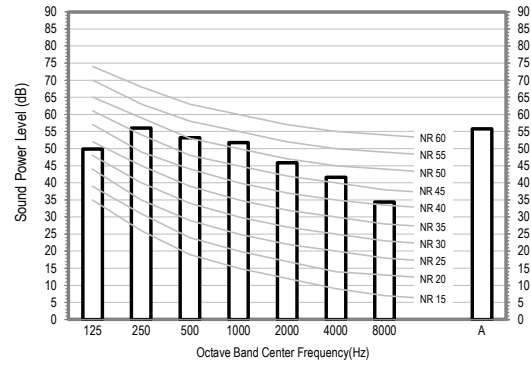

3) AM112DNCDKG/EU

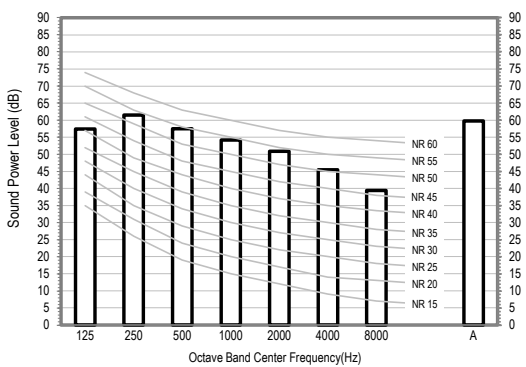

4) AM140DNCDKG/EU

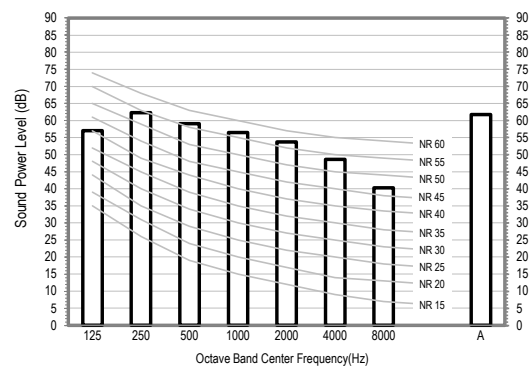

# 8. Temperature and air flow distribution

## Ceiling

### AM056DNCDKG/EU (Ceiling Installation)

- Cooling Air Velocity distribution  
(Discharge angle : 50 degree)

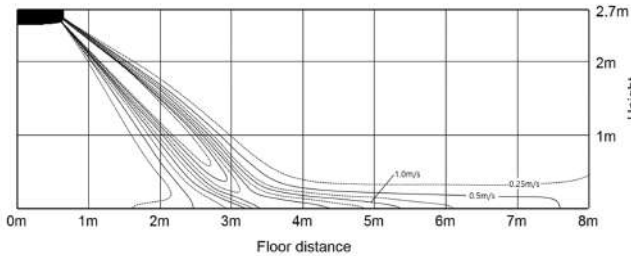

- Cooling temperature distribution  
(Discharge angle : 50 degree)

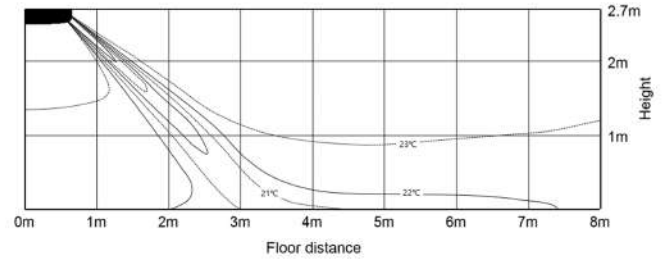

- Heating Air Velocity distribution  
(Discharge angle : 40 degree)

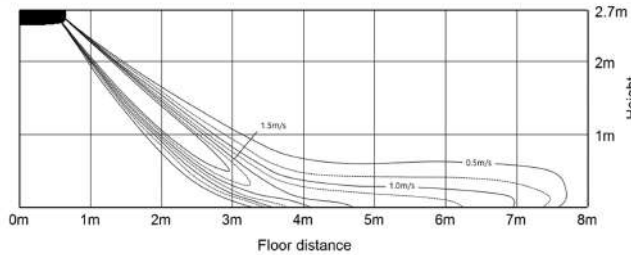

- Heating temperature distribution  
(Discharge angle : 40 degree)

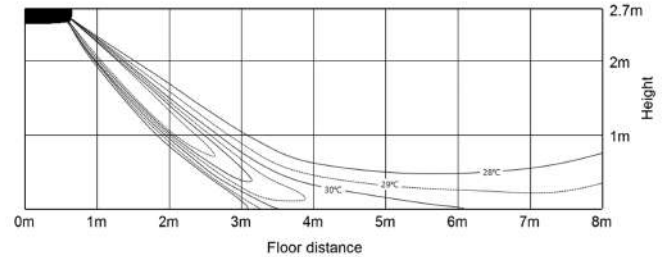

### AM056DNCDKG/EU (Floor Installation)

- Cooling Air Velocity distribution  
(Discharge angle : 50 degree)

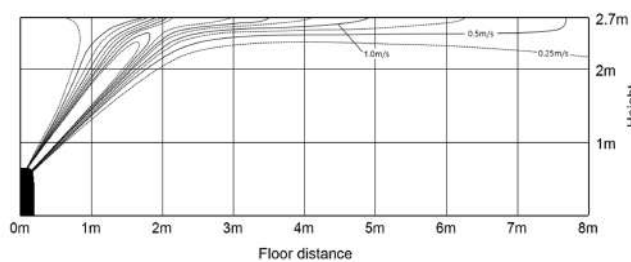

- Cooling temperature distribution  
(Discharge angle : 50 degree)

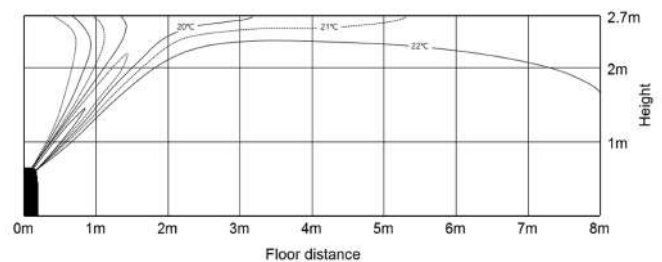

- Heating Air Velocity distribution  
(Discharge angle : 40 degree)

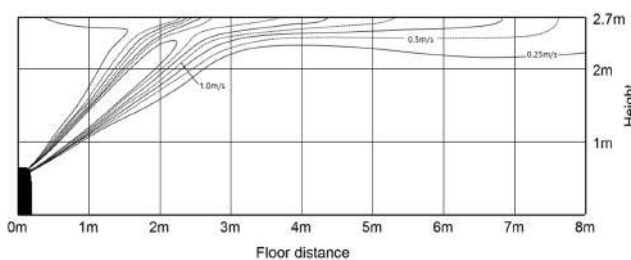

- Heating temperature distribution  
(Discharge angle : 40 degree)

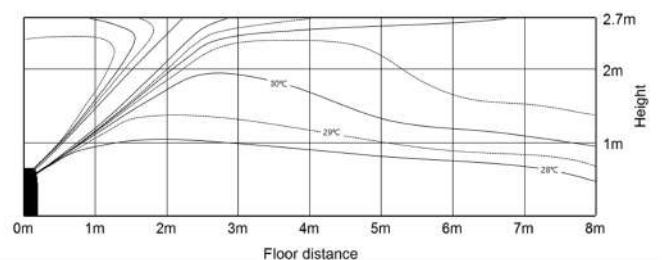

# 8. Temperature and air flow distribution

## Ceiling

AM071DNCDKG/EU

Cooling Air Velocity distribution

(Discharge angle : 32 degree)

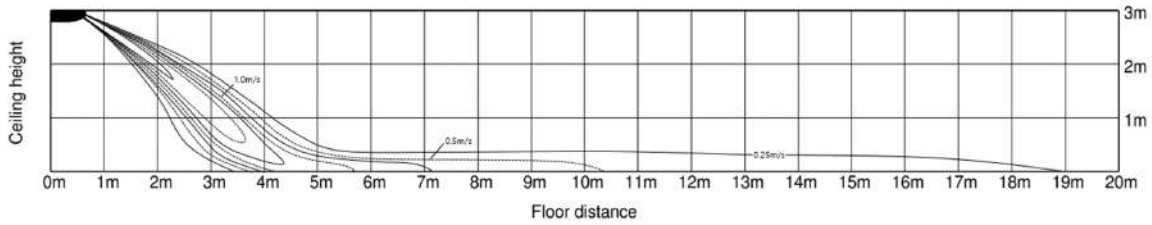

Cooling temperature distribution

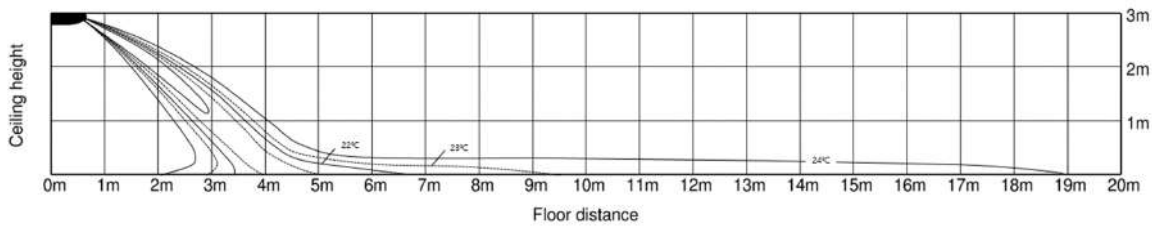

Heating Air Velocity distribution

(Discharge angle : 43 degree)

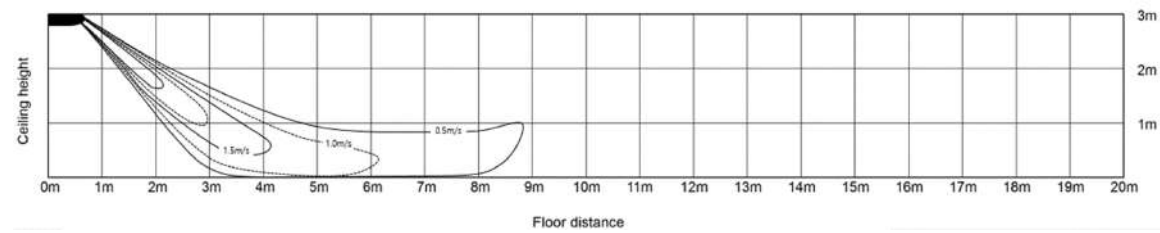

Heating temperature distribution

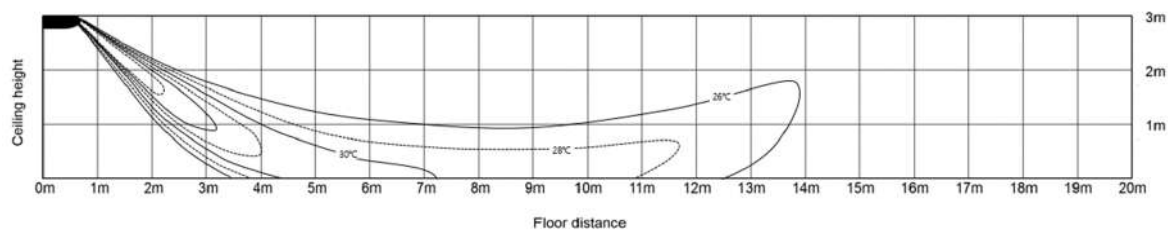

# 8. Temperature and air flow distribution

## Ceiling

AM112DNC DKG/EU

Cooling Air Velocity distribution

(Discharge angle : 32 degree)

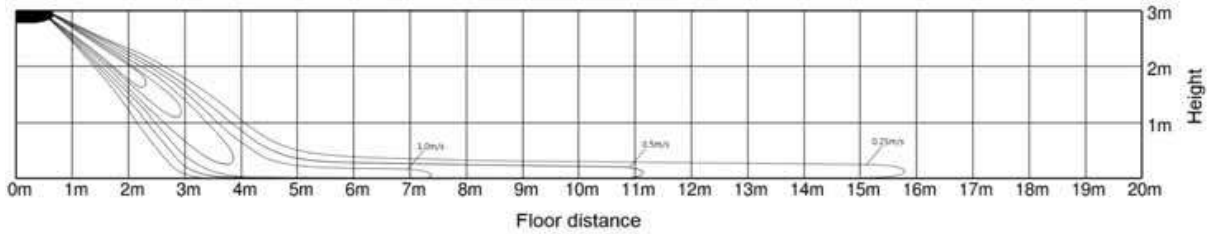

Cooling temperature distribution

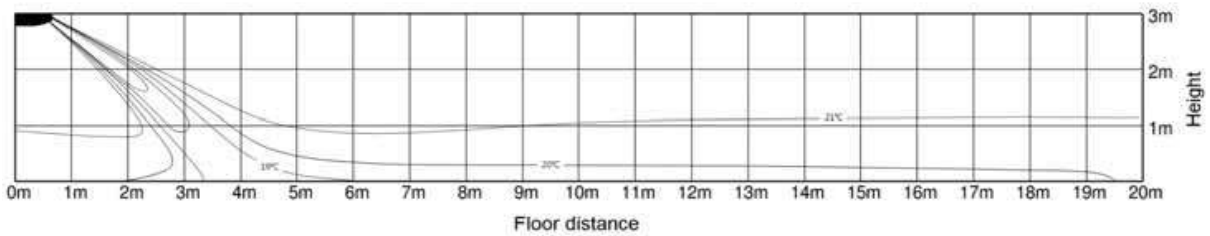

Heating Air Velocity distribution

(Discharge angle : 43 degree)

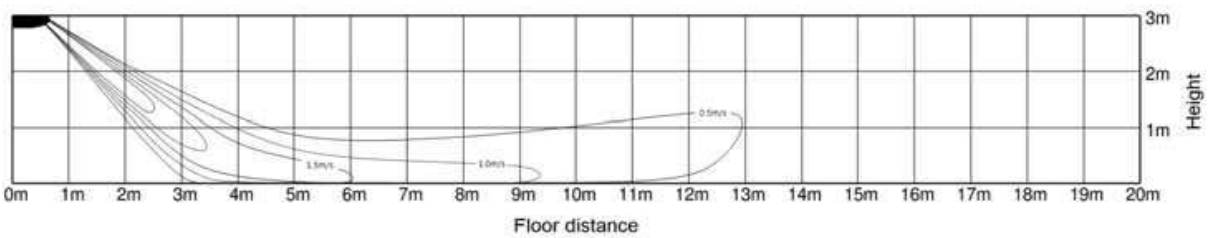

Heating temperature distribution

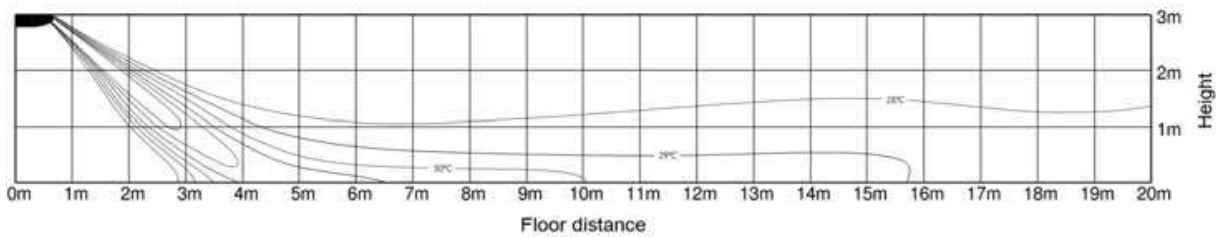

# 8. Temperature and air flow distribution

## Ceiling

AM140DNCDKG/EU

Cooling Air Velocity distribution

(Discharge angle : 42 degree)

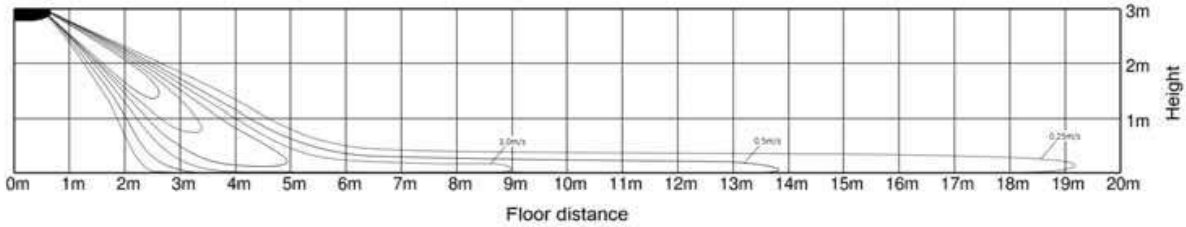

Cooling temperature distribution

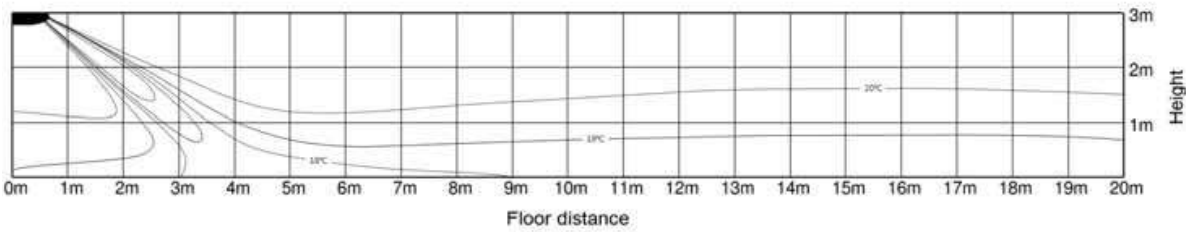

Heating Air Velocity distribution

(Discharge angle : 53 degree)

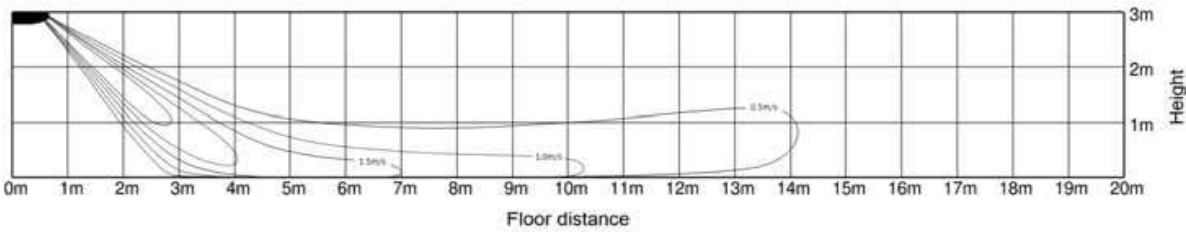

Heating temperature distribution

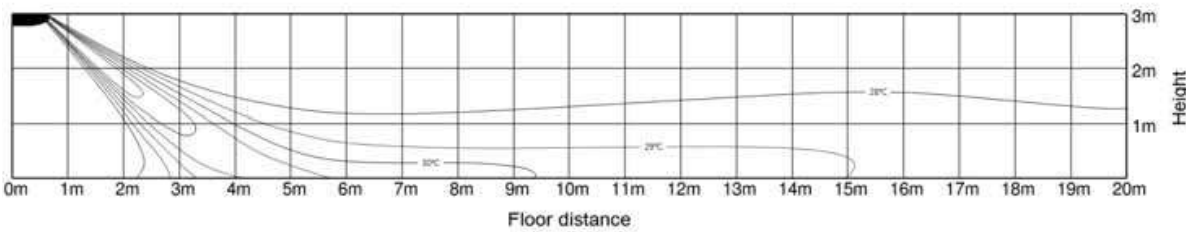

# 9. Piping Diagram

## Ceiling

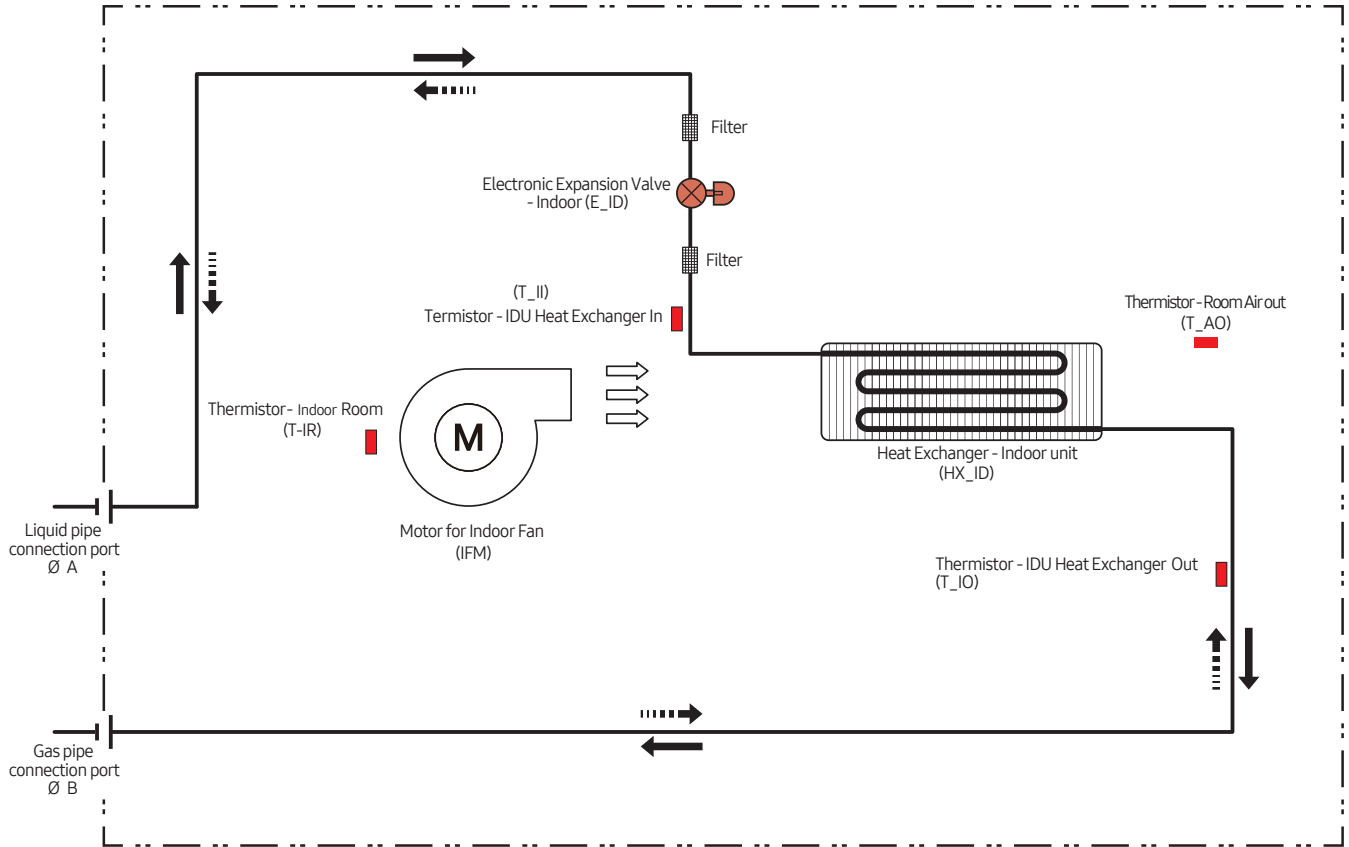

Refrigerant flow	
Cooling	Heating

# Console



---

1. Specification	300
2. Summary Table	302
3. Capacity Table	303
4. Dimensional Drawing	304
5. Center of Gravity	306
6. Electrical Wiring Diagram	307
7. Sound Data	308
8. Temperature and air flow distribution	311
9. Piping Diagram	314

---

# Line-up

## Console

Capacity (kW)				
2.2	2.8	3.6	4.5	5.6
				

# 1. Specification

## Console

Model Name			AM022HEJDKG/EU	AM028HEJDKG/EU	AM036HEJDKG/EU	
Power Supply			Φ, #, V, Hz	1,2,220-240,50/60	1,2,220-240,50/60	1,2,220-240,50/60
Performance	Capacity	Cooling	kW	2.2	2.8	3.6
			Btu/h	7,500	9,600	12,300
		Heating	kW	2.5	3.2	4.0
			Btu/h	8,500	10,900	13,600
Power	Power Input	Cooling	W	16.0	30.0	35.0
		Heating		16.0	30.0	35.0
	Current Input	Cooling	A	0.13	0.25	0.29
		Heating		0.13	0.25	0.29
	Current	MCA	A	TBD	TBD	TBD
		MFA		TBD	TBD	TBD
Heat exchanger	Type		-	Fin & Tube	Fin & Tube	Fin & Tube
	Material	Fin	-	Al	Al	Al
		Tube	-	Cu	Cu	Cu
	Fin Treatment		-	Green Hydrophile	Green Hydrophile	Green Hydrophile
Fan	Type	Type	-	Turbo Fan	Turbo Fan	Turbo Fan
	Quantity		ea	1	1	1
	Air Flow Rate	H/M/L	CMM	6.30 / 5.40 / 4.90	7.00 / 6.00 / 5.00	8.50 / 7.50 / 6.50
			l/s	105.0 / 90.0 / 81.67	116.67 / 100.00 / 83.33	141.67 / 125.00 / 108.33
Fan Motor	Model		-	BLDC	BLDC	BLDC
	Output x n		W	37	37	37
Piping Connections	Liquid Pipe	Type	-	Flare connection	Flare connection	Flare connection
		Φ, mm (inch)	-	6.35 (1/4)	6.35 (1/4)	6.35 (1/4)
	Gas Pipe	Type	-	Flare connection	Flare connection	Flare connection
		Φ, mm (inch)	-	12.7 (1/2)	12.7 (1/2)	12.7 (1/2)
	Heat insulation		-	Both liquid & gas pipes	Both liquid & gas pipes	Both liquid & gas pipes
Drain Pipe		Φ,mm	VP25 (OD 32, ID 25)	VP25 (OD 32, ID 25)	VP25 (OD 32, ID 25)	
Wiring connections	Communication	Min.	mm <sup>2</sup>	0.75	0.75	0.75
		Remark	-	F1, F2	F1, F2	F1, F2
Refrigerant	Type		-	R32	R32	R32
	Electronic Expansion Valve		-	EEV INCLUDED	EEV INCLUDED	EEV INCLUDED
Sound Level	Sound Pressure Level	H/M/L	dB(A)	34 / 32 / 30	38 / 34 / 34	39 / 37 / 34
	Sound Power Level	Cooling		52	58	59
Dimensions	Net Weight		kg	15.5	16.0	16.0
	Shipping Weight		kg	20.5	21.0	21.0
	Net Dimensions (W×H×D)		mm	720 x 620 x 199	720 x 620 x 199	720 x 620 x 199
	Shipping Dimensions (W×H×D)		mm	805 x 297 x 705	805 x 297 x 705	805 x 297 x 705
Drain Pump	Drain Pump		-	-	-	-
	Max. lifting Height / Displacement		mm / Liter/h	-	-	-

### NOTE

- Specification may be subject to change without prior notice.
  - 1) Capacities are based on (Equivalent refrigerant piping 7.5m, Level differences 0m);
    - Cooling : Indoor temperature 27°C DB, 19°C WB / Outdoor temperature 35°C DB, 24°C WB
    - Heating : Indoor temperature 20°C DB, 15°C WB / Outdoor temperature 7°C DB, 6°C WB
  - 2) Sound level was acquired in an anechoic room. Thus actual noise level may be different depending on the installation conditions.
  - 3) These products contain R32 (GWP=675) which is fluorinated greenhouse gas.
  - 4) Select wire size based on the value of MCA

# 1. Specification

## Console

Model Name			AM045HEJDKG/EU	AM056HEJDKG/EU	
Power Supply			Φ, #, V, Hz	1,2,220-240,50/60	
Performance	Capacity	Cooling	kW	4.5	5.6
			Btu/h	15,400	19,100
		Heating	kW	5.0	6.3
			Btu/h	17,100	21,500
Power	Power Input	Cooling	W	36.0	62.0
		Heating	W	36.0	62.0
	Current Input	Cooling	A	0.30	0.49
		Heating	A	0.30	0.49
	Current	MCA	A	TBD	TBD
		MFA	A	TBD	TBD
Heat exchanger	Type		-	Fin & Tube	Fin & Tube
	Material	Fin	-	Al	Al
		Tube	-	Cu	Cu
	Fin Treatment		-	Green Hydrophile	Green Hydrophile
Fan	Type	Type	-	Turbo Fan	Turbo Fan
	Quantity		ea	1	1
	Air Flow Rate	H/M/L	CMM	11.30 / 9.80 / 8.20	13.00 / 11.50 / 10.00
			l/s	188.33 / 163.33 / 136.67	216.67 / 191.67 / 166.67
Fan Motor	Model		-	BLDC	BLDC
	Output x n		W	37	37
Piping Connections	Liquid Pipe	Type	-	Flare connection	Flare connection
		Φ, mm (inch)	-	6.35 (1/4)	6.35 (1/4)
	Gas Pipe	Type	-	Flare connection	Flare connection
		Φ, mm (inch)	-	12.7 (1/2)	12.7 (1/2)
	Heat insulation		-	Both liquid & gas pipes	Both liquid & gas pipes
Drain Pipe		Φ,mm	VP25 (OD 32, ID 25)	VP25 (OD 32, ID 25)	
Wiring connections	Communication	Min.	mm <sup>2</sup>	0.75	0.75
		Remark	-	F1, F2	F1, F2
Refrigerant	Type		-	R32	R32
	Electronic Expansion Valve		-	EEV INCLUDED	EEV INCLUDED
Sound Level	Sound Pressure Level	H/M/L	dB(A)	42 / 39 / 36	43 / 40 / 37
	Sound Power Level	Cooling		63	64
Dimensions	Net Weight		kg	16.0	16.0
	Shipping Weight		kg	21.0	21.0
	Net Dimensions (W×H×D)		mm	720 x 620 x 199	720 x 620 x 199
	Shipping Dimensions (W×H×D)		mm	805 x 297 x 705	805 x 297 x 705
Drain Pump	Drain Pump		-	-	-
	Max. lifting Height / Displacement		mm / Liter/h	-	-

### NOTE

- Specification may be subject to change without prior notice.
  - 1) Capacities are based on (Equivalent refrigerant piping 7.5m, Level differences 0m);
    - Cooling : Indoor temperature 27°C DB, 19°C WB / Outdoor temperature 35°C DB, 24°C WB
    - Heating : Indoor temperature 20°C DB, 15°C WB / Outdoor temperature 7°C DB, 6°C WB
  - 2) Sound level was acquired in an anechoic room. Thus actual noise level may be different depending on the installation conditions.
  - 3) These products contain R32 (GWP=675) which is fluorinated greenhouse gas.
  - 4) Select wire size based on the value of MCA

## 2. Summary Table

### Console

#### Performance Characteristics

Model Code	Net Weight (kg)	Fan Speed	Nominal Capacity (kW)			Airflow (CMM)	Sound Pressure (dBA)	Sound Power (dBA)
			Cooling	Sensible	Heating			
AM022HEJDKG/EU	15.5	High	2.2	1.5	2.5	6.3	34	52
		Mid	1.9	1.3	2.3	5.4	32	-
		Low	1.8	1.2	2.2	4.9	30	-
AM028HEJDKG/EU	16.0	High	2.8	1.9	3.2	7.0	38	58
		Mid	2.4	1.6	3.0	6.0	34	-
		Low	2.1	1.4	2.7	5.0	34	-
AM036HEJDKG/EU	16.0	High	3.6	2.4	4.0	8.5	39	59
		Mid	3.2	2.1	3.8	7.5	37	-
		Low	2.8	1.9	3.5	6.5	34	-
AM045HEJDKG/EU	16.0	High	4.5	3.0	5.0	11.3	42	63
		Mid	4.0	2.7	4.7	9.8	39	-
		Low	3.4	2.3	4.3	8.2	36	-
AM056HEJDKG/EU	16.0	High	5.6	3.8	6.3	13.0	43	64
		Mid	5.0	3.4	5.9	11.5	40	-
		Low	4.4	3.0	5.5	10.0	37	-

#### NOTE

- Sound data is based on cooling operation.

#### Electric Characteristics

Indoor Unit	Power Supply (Ø, #, V, Hz)	Power Input (W)	Current Input (A)	MCA (A)	MFA (A)	FLA (A)
AM022HEJDKG/EU	1,2,220~240,50/60	16.0	0.1	TBD	TBD	TBD
AM028HEJDKG/EU	1,2,220~240,50/60	30.0	0.3	TBD	TBD	TBD
AM036HEJDKG/EU	1,2,220~240,50/60	35.0	0.3	TBD	TBD	TBD
AM045HEJDKG/EU	1,2,220~240,50/60	36.0	1.3	TBD	TBD	TBD
AM056HEJDKG/EU	1,2,220~240,50/60	62.0	1.5	TBD	TBD	TBD

#### NOTE

- MCA : Minimum circuit amperes
- MFA : Maximum fuse amperes
- Select wire size based on the value of MCA

# 3. Capacity Table

## Console

### Cooling

TC : Total Capacity, SHC : Sensible Heat Capacity

Capacity Index	Outdoor Air Temp. (°C, DB)	Indoor temperature													
		20(°C, DB)		23(°C, DB)		26(°C, DB)		27(°C, DB)		28(°C, DB)		30(°C, DB)		32(°C, DB)	
		14(°C, WB)		16(°C, WB)		18(°C, WB)		19(°C, WB)		20(°C, WB)		22(°C, WB)		24(°C, WB)	
		TC	SHC	TC	SHC	TC	SHC	TC	SHC	TC	SHC	TC	SHC	TC	SHC
022	35	1.5	1.3	1.8	1.5	2.1	1.5	2.2	1.5	2.3	1.5	2.4	1.5	2.6	1.4
028	35	1.9	1.6	2.3	1.8	2.6	2.0	2.8	1.9	2.9	1.9	3.1	1.9	3.3	1.8
036	35	2.5	2.1	2.9	2.2	3.4	2.3	3.6	2.4	3.7	2.4	4.0	2.4	4.2	2.3
045	35	3.1	2.4	3.7	2.7	4.3	2.9	4.5	3.0	4.7	3.0	5.0	3.0	5.3	2.8
056	35	3.9	3.0	4.6	3.4	5.3	3.7	5.6	3.8	5.8	3.8	6.2	3.8	6.6	3.5

### Heating

TC : Total Capacity (kW)

Capacity Index	Outdoor Air Temp. (°C)		Indoor temperature (°C, DB)				
			16(°C, DB)	18(°C, DB)	20(°C, DB)	22(°C, DB)	24(°C, DB)
			TC	TC	TC	TC	TC
	DB	WB	kW	kW	kW	kW	kW
022	7.0	6.0	2.8	2.7	2.5	2.3	2.2
028	7.0	6.0	3.3	3.2	3.2	3.0	2.7
035	7.0	6.0	4.1	4.1	4.0	3.7	3.4
045	7.0	6.0	5.2	5.1	5.0	4.6	4.2
056	7.0	6.0	6.5	6.4	6.3	5.8	5.3

### NOTE

- The performance table shows the average value of each conditions.

# 4. Dimensional Drawing

## Console

AM022HEJDKG/EU, AM028HEJDKG/EU, AM036HEJDKG/EU

Units : mm [inches]

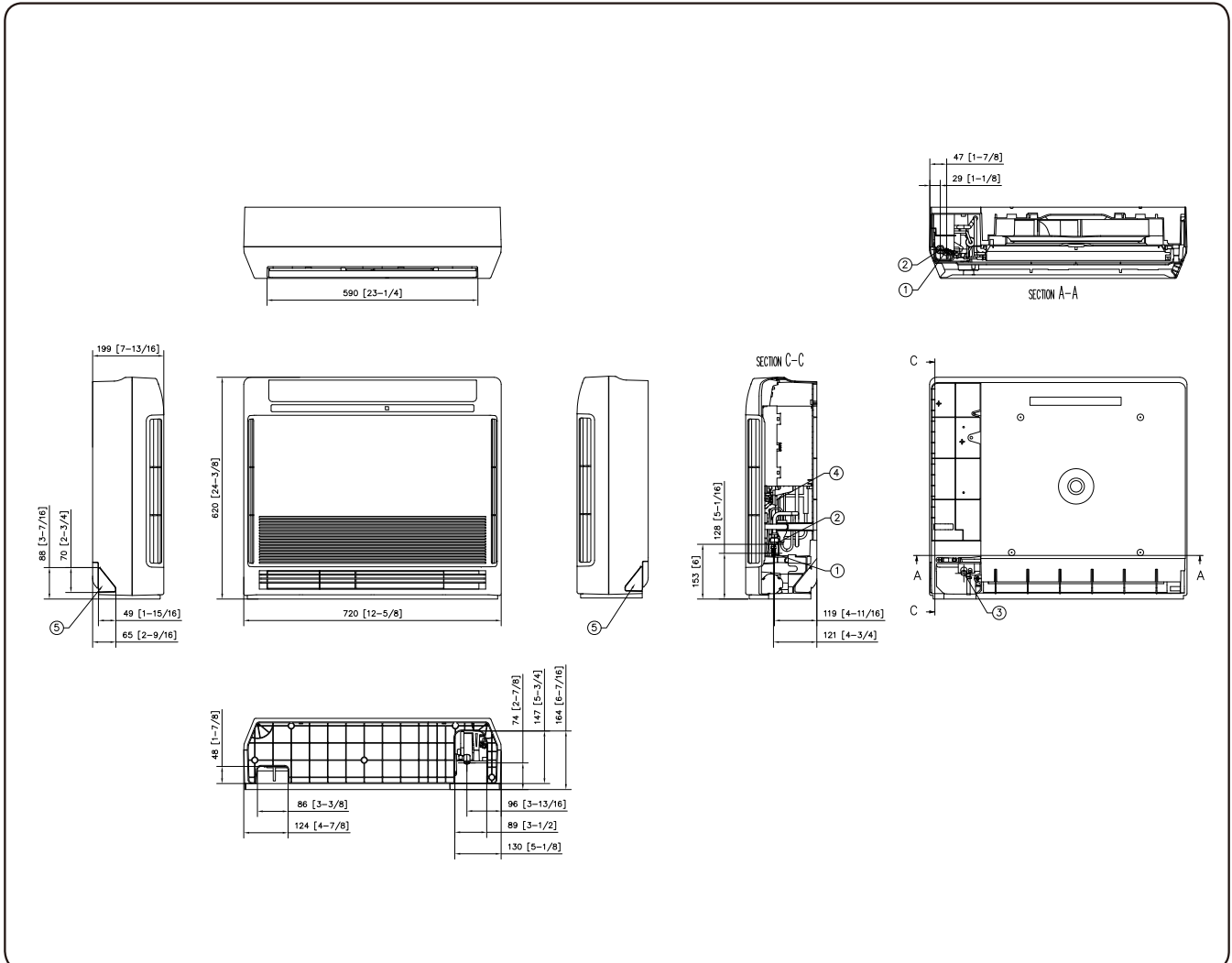

No.	Name	Description
1	Liquid pipe connection	Φ6.35(1/4)
2	Gas pipe connection	Φ12.7(1/2)
3	Drain pipe connection	VP25 (OD 32, ID 25)
4	Power supply & Communication wiring conduit	-
5	Fresh air intake	-

# 4. Dimensional Drawing

## Console

AM045HEJDKG/EU, AM056HEJDKG/EU

Units : mm [inches]

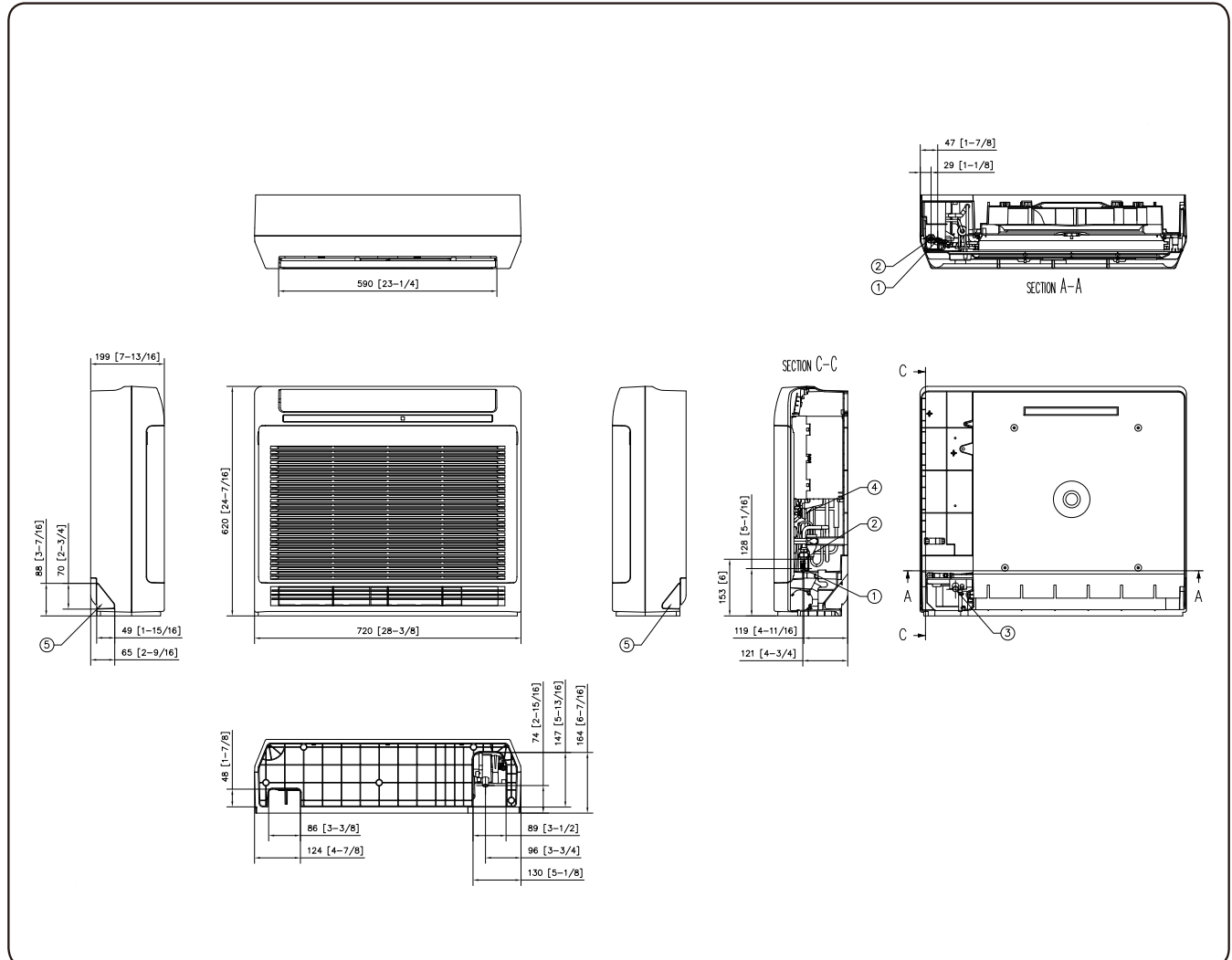

No.	Name	Description
1	Liquid pipe connection	Φ6.35(1/4)
2	Gas pipe connection	Φ12.7(1/2)
3	Drain pipe connection	VP25 (OD 32, ID 25)
4	Power supply & Communication wiring conduit	-
5	Fresh air intake	-

# 5. Center of Gravity

## Console

Units : mm [inches]

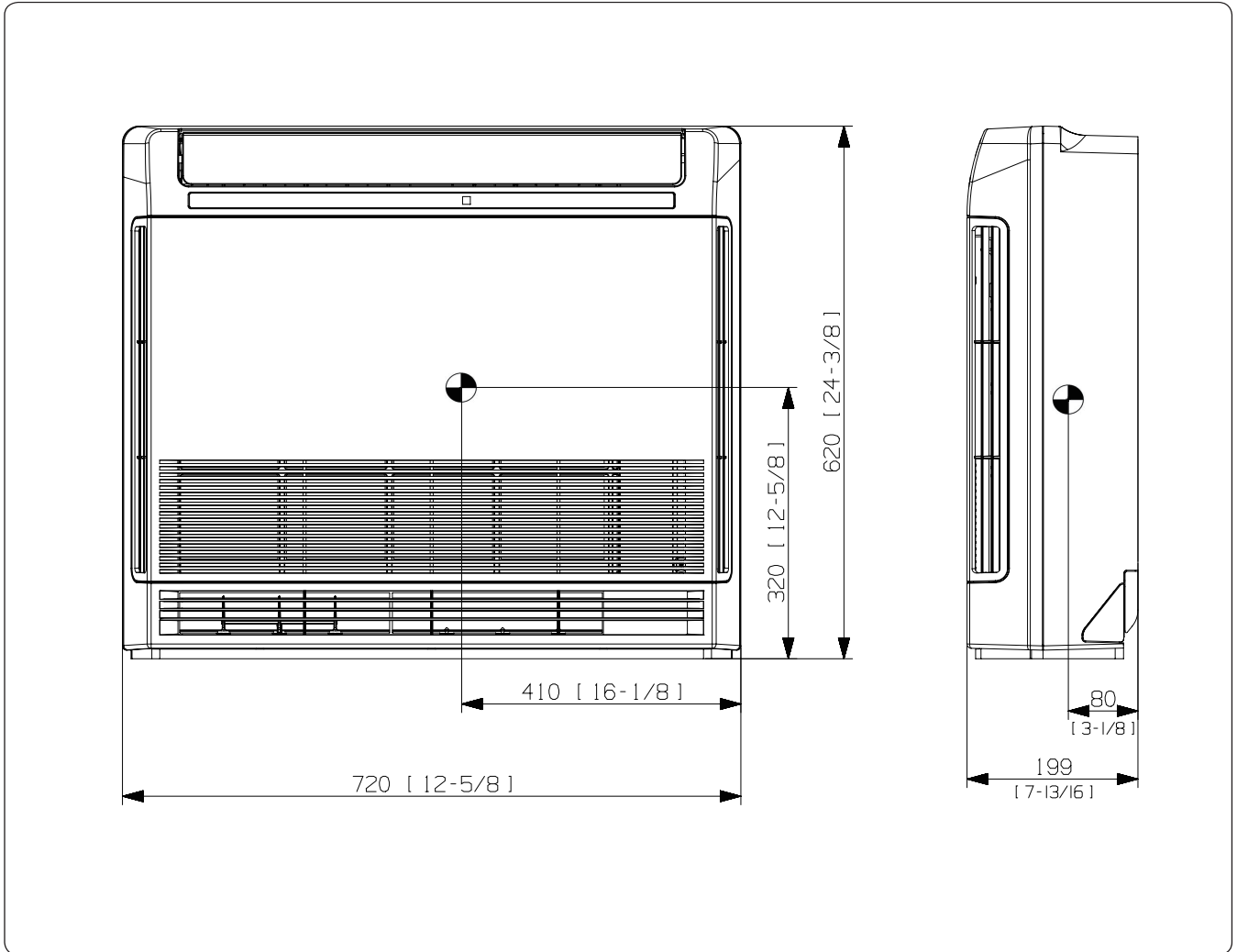

# 6. Electrical Wiring Diagram

## Console

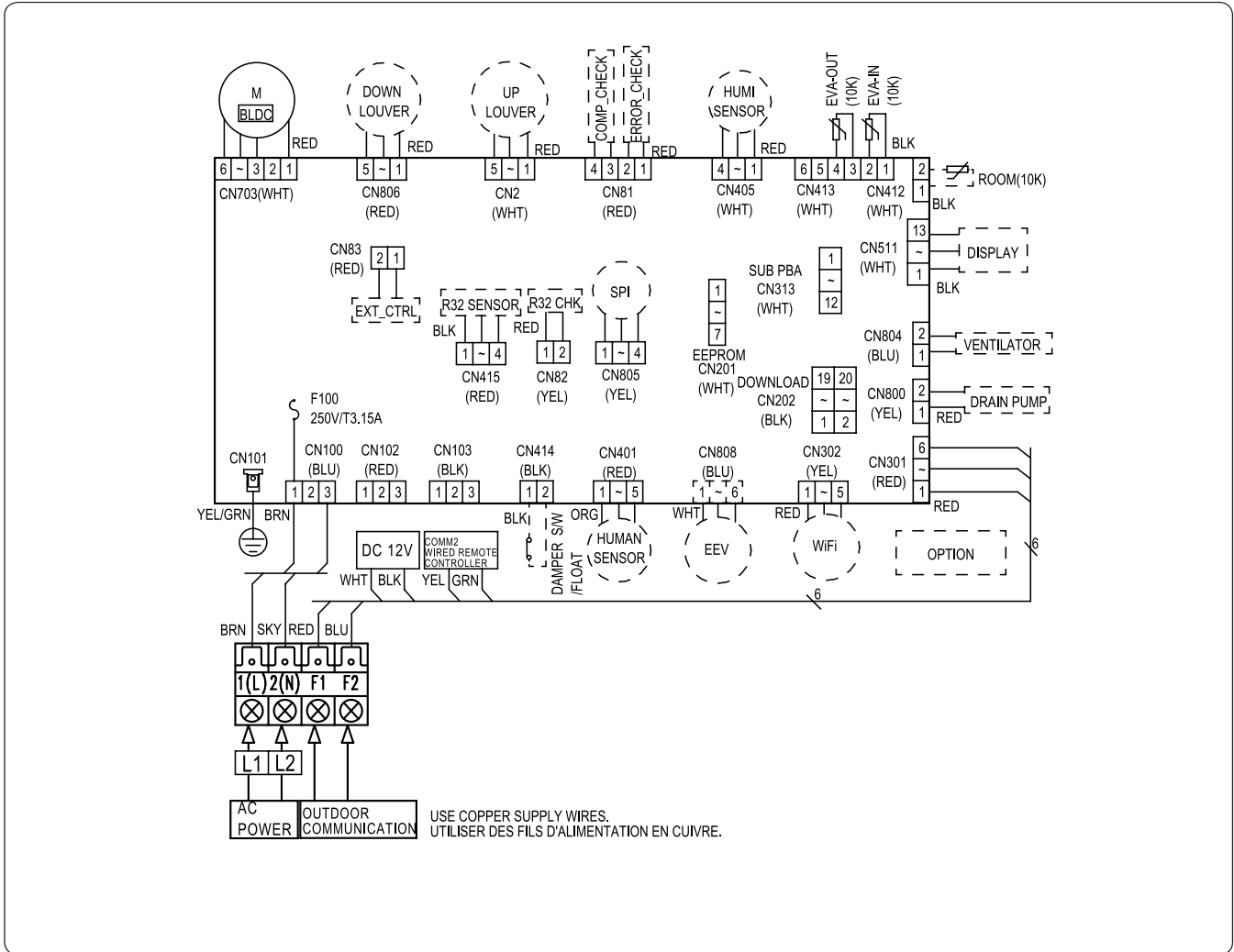

F100	Fuse	ROOM(10K)	Thermistor - Indoor Room
EEV	Electronic Expansion Valve	EVA IN (10K)	Thermistor - IDU heat exchanger In
M-BLDC	Motor for Indoor Fan	EVA OUT (10K)	Thermistor - IDU heat exchanger Out
DISPLAY	Panel LED display	EEPROM	EEPROM SUB PBA
ERROR CHECK	Contact output port for error check	SUB PBA	SUB PBA for wired remote control communication
COMP CHECK	Contact output port for compressor operation check	VENTILATOR	Contact output port for Ventilator control
EXTERNAL CTRL	Input port for external contact control		

### NOTE

- This wiring diagram applies only to the Indoor unit.
- Symbols show as follow :  
blk: black, red: red, blu: blue, wht: white, yel: yellow, brn: brown, sky: skyblue: grn: green
- For connection wiring indoor-outdoor transmission F1-F2, indoor-wired remote controller transmission F3-F4.
- Protective earth(screw), : connector, : The wire quantity

# 7. Sound Data

## Console

### Sound Pressure level

Unit: dB(A)

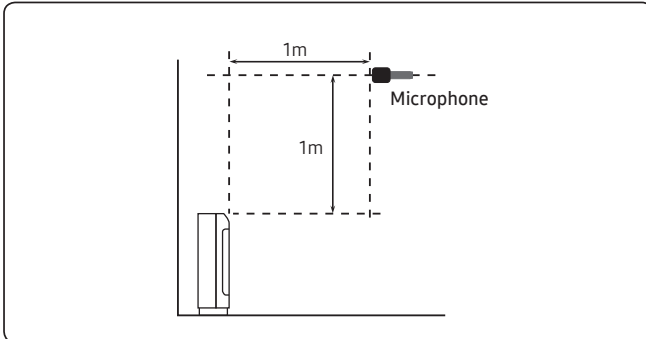

Model	High	Mid	Low
AM022HEJDKG/EU	34	32	30
AM028HEJDKG/EU	38	34	34
AM036HEJDKG/EU	39	37	34
AM045HEJDKG/EU	42	39	36

- NR Curve

1) AM022HEJDKG/EU

2) AM028HEJDKG/EU

# TBD

3) AM036HEJDKG/EU

4) AM045HEJDKG/EU

### NOTE

- Specifications may be subject to change without prior notice.
- Sound pressure Level
  - Sound pressure level is obtained in an anechoic room.
  - Sound pressure level is a relative value, depending on the distance and acoustic environment.
  - Sound pressure level may differ depending on operation condition.
  - dBA = A weighted sound pressure level
  - Reference acoustic pressure 0 dB = 20μPa

# 7. Sound Data

## Console

### Sound Pressure level

Unit: dB(A)

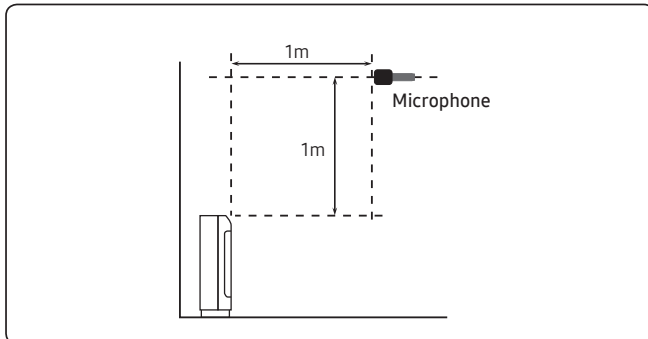

Model	High	Mid	Low
AM056HEJDKG/EU	43	40	37

- NR Curve  
1) AM056HEJDKG/EU

# TBD

### NOTE

- Specifications may be subject to change without prior notice.
- Sound pressure Level
  - Sound pressure level is obtained in an anechoic room.
  - Sound pressure level is a relative value, depending on the distance and acoustic environment.
  - Sound pressure level may differ depending on operation condition.
  - dBA = A weighted sound pressure level
  - Reference acoustic pressure 0 dB = 20 $\mu$ Pa

# 7. Sound Data

---

## Console

---

### Sound Power level

 **NOTE**

Unit: dB(A)

- Specifications may be subject to change without prior notice
  - Sound power level is an absolute value that a sound source generates.
  - dBA = A-weighted sound power level.
  - Reference power : 1pW.
  - Measured according to ISO 3741.
- NR Curve

Model	Power
AM022HEJDKG/EU	52
AM028HEJDKG/EU	58
AM036HEJDKG/EU	59
AM045HEJDKG/EU	63
AM056HEJDKG/EU	64

1) AM022HEJDKG/EU

2) AM028HEJDKG/EU

TBD

3) AM036HEJDKG/EU

4) AM045HEJDKG/EU

5) AM056HEJDKG/EU

---

# 8. Temperature and air flow distribution

## Console

### AM022HEJDKG/EU

- Cooling Air Velocity distribution  
(Discharge angle : 40 degree)

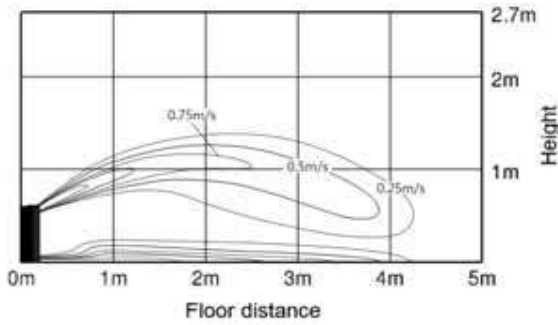

- Cooling temperature distribution  
(Discharge angle : 40 degree)

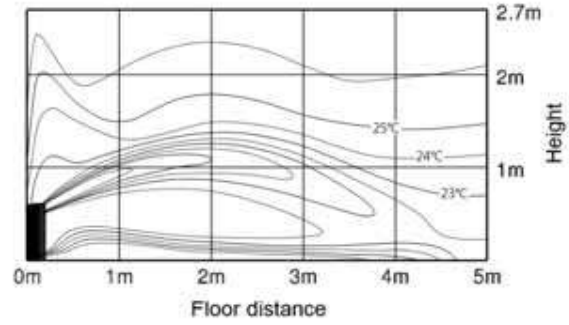

- Heating Air Velocity distribution  
(Discharge angle : 4 degree)

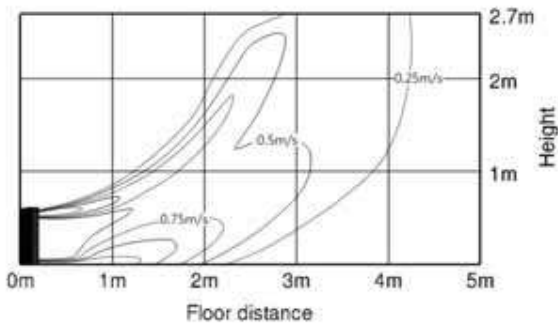

- Heating temperature distribution  
(Discharge angle : 4 degree)

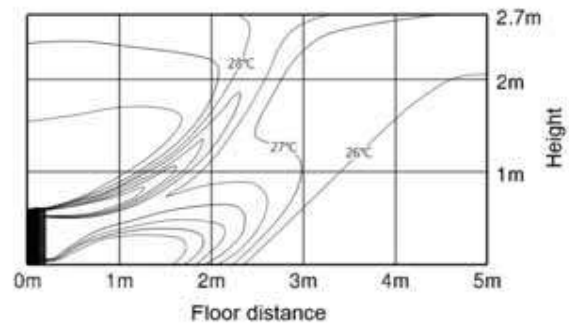

### AM028HEJDKG/EU

- Cooling Air Velocity distribution  
(Discharge angle : 40 degree)

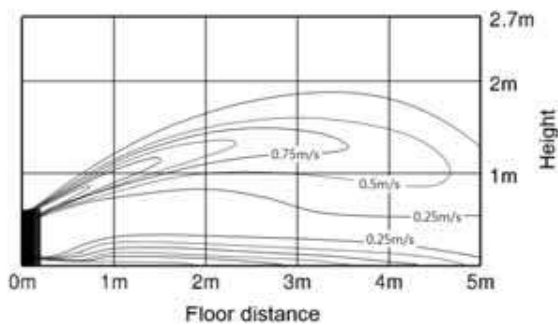

- Cooling temperature distribution  
(Discharge angle : 40 degree)

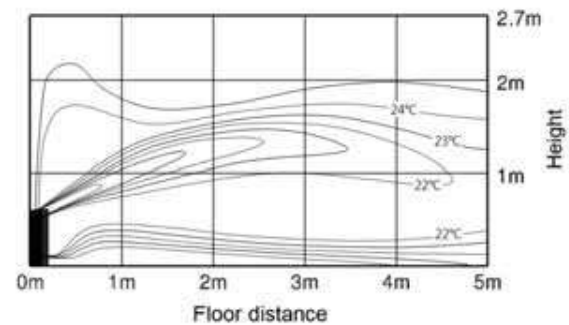

- Heating Air Velocity distribution  
(Discharge angle : 4 degree)

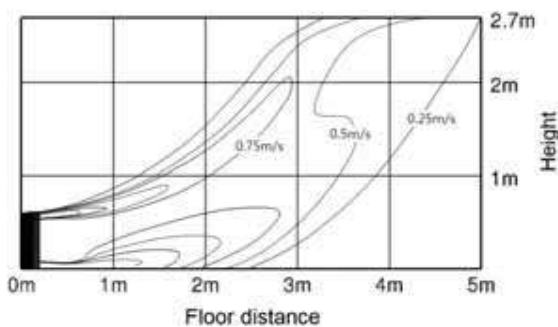

- Heating temperature distribution  
(Discharge angle : 4 degree)

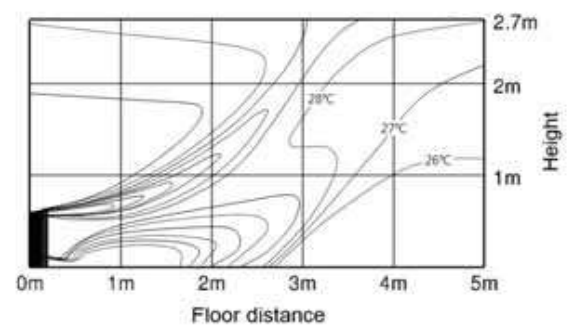

# 8. Temperature and air flow distribution

## Console

### AM036HEJDKG/EU

- Cooling Air Velocity distribution  
(Discharge angle : 40 degree)

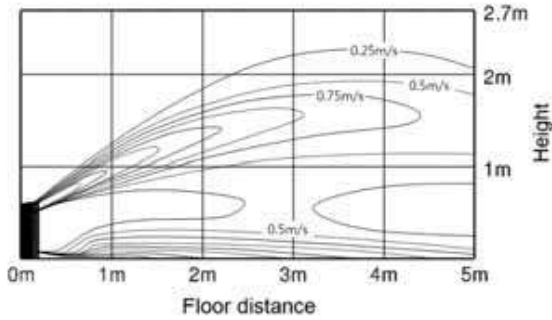

- Cooling temperature distribution  
(Discharge angle : 40 degree)

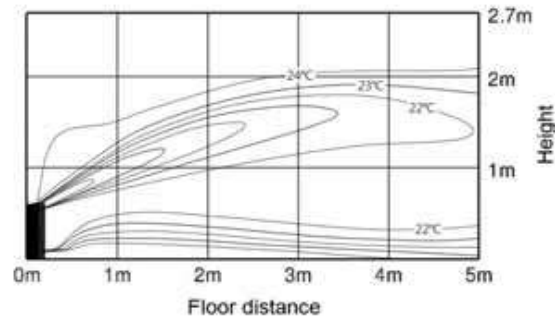

- Heating Air Velocity distribution  
(Discharge angle : 4 degree)

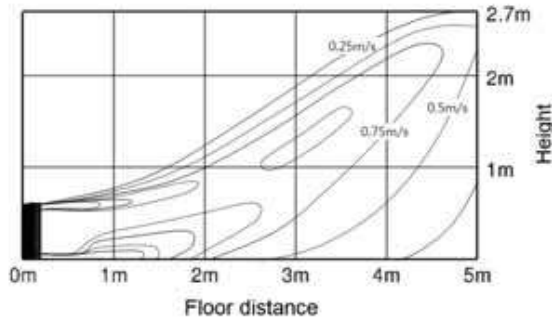

- Heating temperature distribution  
(Discharge angle : 4 degree)

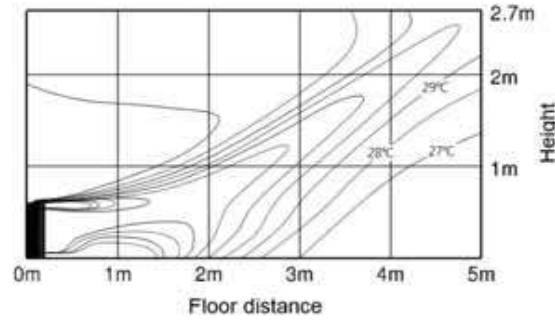

### AM045HEJDKG/EU

- Cooling Air Velocity distribution  
(Discharge angle : 40 degree)

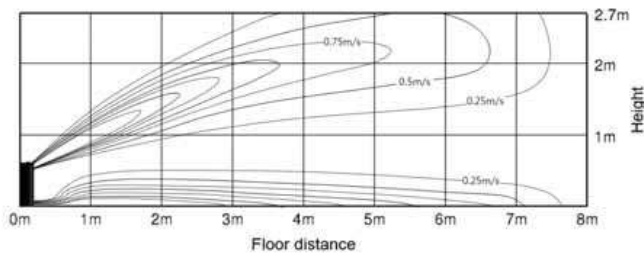

- Cooling temperature distribution  
(Discharge angle : 40 degree)

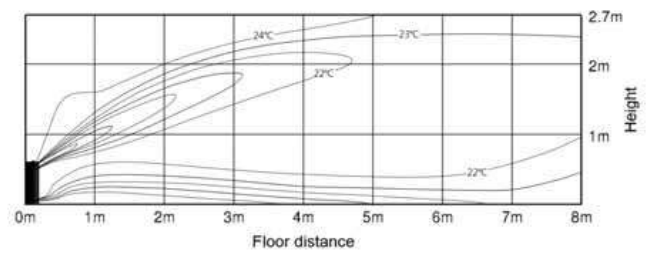

- Heating Air Velocity distribution  
(Discharge angle : 4 degree)

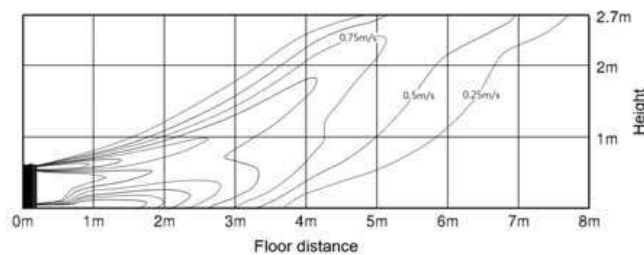

- Heating temperature distribution  
(Discharge angle : 4 degree)

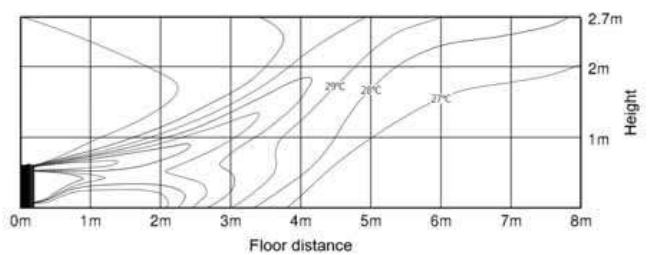

# 8. Temperature and air flow distribution

## Console

### AM056HEJDKG/EU

- Cooling Air Velocity distribution  
(Discharge angle : 40 degree)

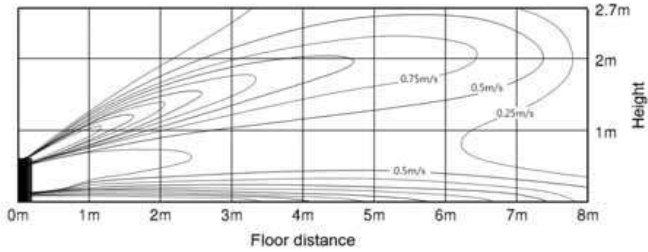

- Cooling temperature distribution  
(Discharge angle : 40 degree)

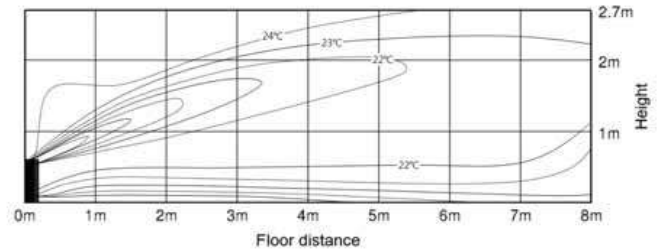

- Heating Air Velocity distribution  
(Discharge angle : 4 degree)

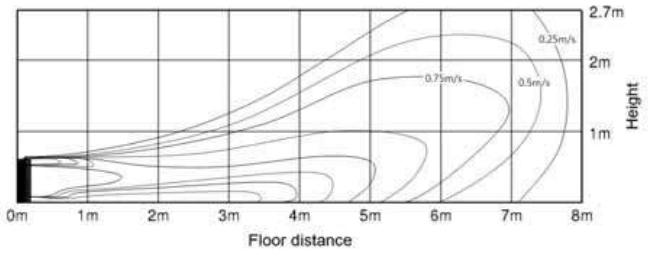

- Heating temperature distribution  
(Discharge angle : 4 degree)

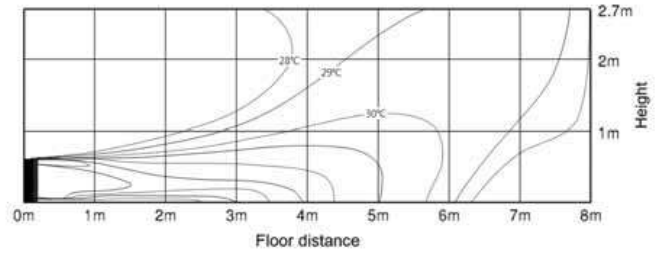

# 9. Piping Diagram

## Console

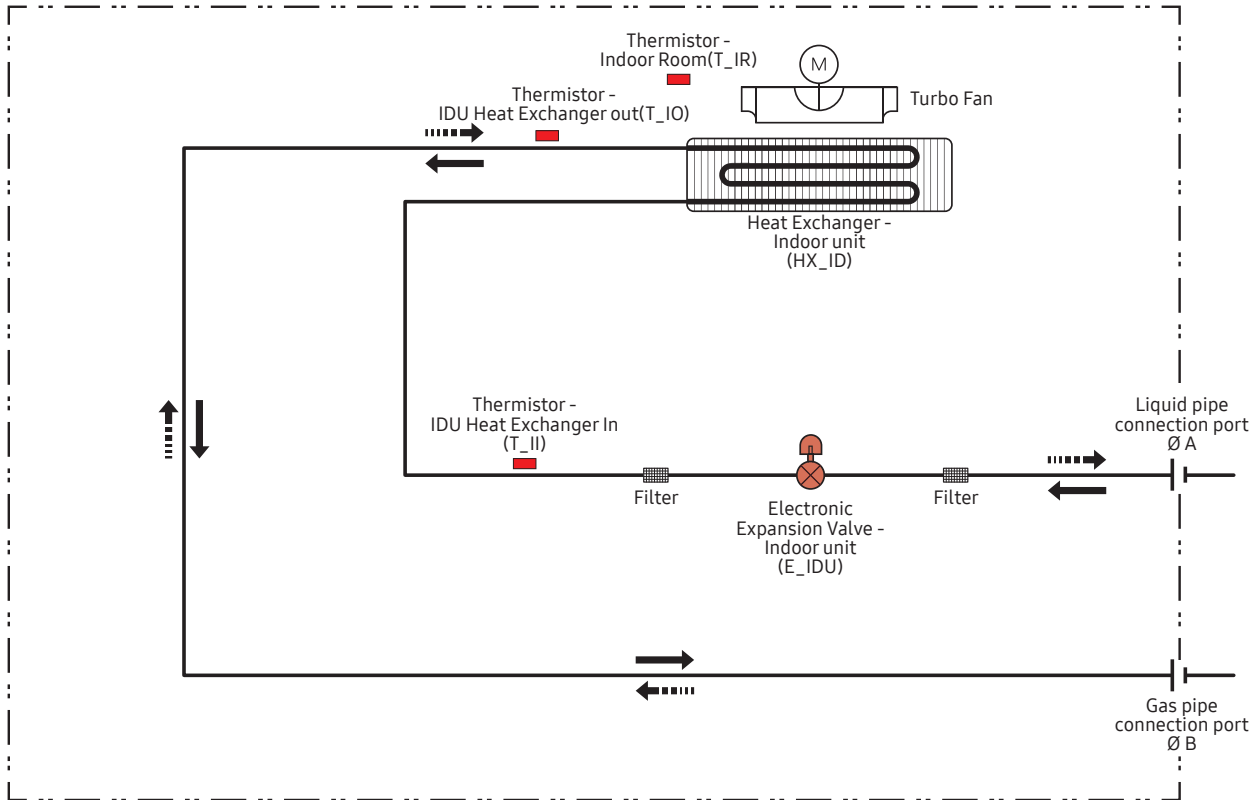

Refrigerant flow	
Cooling	Heating
→	····→

# PAC



---

1. Specification	317
2. Summary Table	318
3. Capacity Table	319
4. Dimensional Drawing	320
5. Center of Gravity	322
6. Electrical Wiring Diagram	324
7. Sound Data	326
8. Temperature and air flow distribution	328
9. Piping Diagram	330

---

# Line-up

PAC

Capacity (kW)	
14.0	28.0
	

# 1. Specification

## PAC

Model Name				AM140HEPDKG/EU	AM280HEPDKG/EU
Power Supply			Φ, #, V, Hz	1,2,220-240,50/60	1,2,220-240,50/60
Performance	Capacity	Cooling	kW	14.0	28.0
			Btu/h	47,800	95,500
		Heating	kW	16.0	31.5
			Btu/h	54,600	107,500
Power	Power Input	Cooling	W	190.0	400.0
		Heating		190.0	400.0
	Current Input	Cooling	A	0.90	2.70
		Heating		0.90	2.70
	Current	MCA	A	TBD	TBD
		MFA		TBD	TBD
Heat exchanger	Type		-	Fin & Tube	Fin & Tube
	Material	Fin	-	Al	Al
		Tube	-	Cu	Cu
	Fin Treatment		-	Green Hydrophile	Green Hydrophile
Fan	Type	Type	-	Sirocco Fan	Sirocco Fan
	Quantity		ea	1	1
	Air Flow Rate	H/M/L	CMM	35.00/30.50/27.50	68.00/63.00/58.00
			l/s	583.33/508.33/458.33	2401.5/2224.9/2048.3
Fan Motor	Model		-	BLDC	BLDC
	Output x n		W	154	630
Piping Connections	Liquid Pipe		Type	Flare connection	Flare connection
			Φ, mm (inch)	9.52 (3/8)	9.52 (3/8)
	Gas Pipe		Type	Flare connection	Flare connection
			Φ, mm (inch)	15.88 (5/8)	22.22 (7/8)
	Heat insulation		-	Both liquid & gas pipes	Both liquid & gas pipes
Drain Pipe		Φ,mm	VP25 (OD 32, ID 25)	VP25 (OD 32, ID 25)	
Wiring connections	Communication	Min.	mm <sup>2</sup>	0.75	0.75
	Remark		-	F1, F2	F1, F2
Refrigerant	Type		-	R32	R32
	Electronic Expansion Valve		-	EEV INCLUDED	EEV INCLUDED
Sound Level	Sound Pressure Level	H/M/L	dB(A)	54 / - /47	58 / 56 / 54
	Sound Power Level	Cooling		70	74
Dimensions	Net Weight		kg	48.0	108.0
	Shipping Weight		kg	55.0	127.0
	Net Dimensions (W×H×D)		mm	610 x 1,850 x 400	1,100 x 1,800 x 485
	Shipping Dimensions (W×H×D)		mm	705 x 1,963 x 493	1,177 x 1,950 x 563
Drain Pump	Drain Pump		-	-	-
	Max. lifting Height /		mm / Liter/h	-	-

### NOTE

- Specification may be subject to change without prior notice.
  - 1) Capacities are based on (Equivalent refrigerant piping 7.5m, Level differences 0m);
    - Cooling : Indoor temperature 27°C DB, 19°C WB / Outdoor temperature 35°C DB, 24°C WB
    - Heating : Indoor temperature 20°C DB, 15°C WB / Outdoor temperature 7°C DB, 6°C WB
  - 2) Sound level was acquired in an anechoic room. Thus actual noise level may be different depending on the installation conditions.
  - 3) These products contain R32 (GWP=675) which is fluorinated greenhouse gas.
  - 4) Select wire size based on the value of MCA

## 2. Summary Table

### PAC

#### Performance Characteristics

Model Code	Net Weight (kg)	Fan Speed	Nominal Capacity (kW)			Airflow (CMM)	Sound Pressure (dBA)	Sound Power (dBA)
			Cooling	Sensible	Heating			
AM140HEPDKG/EU	48.0	High	14.0	10.8	16.0	35.0	54	70
		Mid	12.4	9.6	14.9	30.5	-	-
		Low	11.3	8.7	14.2	27.5	47	-
AM280HEPDKG/EU	108.0	High	28.0	21.8	31.5	68.0	58	74
		Mid	26.2	20.4	30.3	63.0	56	-
		Low	24.4	19.0	29.1	58.0	54	-

#### NOTE

- Sound data is based on cooling operation.

#### Electric Characteristics

Indoor Unit	Power Supply (Ø, #, V, Hz)	Power Input (W)	Current Input (A)	MCA (A)	MFA (A)	FLA (A)
AM140HEPDKG/EU	1,2,220~240,50/60	190	0.9	TBD	TBD	TBD
AM280HEPDKG/EU	1,2,220~240,50/60	400	2.7	TBD	TBD	TBD

#### NOTE

- MCA : Minimum circuit amperes
- MFA : Maximum fuse amperes
- Select wire size based on the value of MCA

# 3. Capacity Table

## PAC

### Cooling

TC : Total Capacity, SHC : Sensible Heat Capacity

Capacity Index	Outdoor Air Temp. ( °C,DB )	Indoor temperature													
		20(°C,DB)		23(°C,DB)		26(°C,DB)		27(°C,DB)		28(°C,DB)		30(°C,DB)		32(°C,DB)	
		14(°C,WB)		16(°C,WB)		18(°C,WB)		19(°C,WB)		20(°C,WB)		22(°C,WB)		24(°C,WB)	
		TC	SHC	TC	SHC	TC	SHC	TC	SHC	TC	SHC	TC	SHC	TC	SHC
140	35	9.70	8.58	11.40	9.69	13.10	10.50	14.00	10.80	14.50	10.80	15.50	10.80	16.50	10.60
280	35	19.70	17.60	23.30	19.60	26.50	21.20	28.00	21.80	29.90	22.60	32.70	23.50	33.70	23.00

### Heating

TC : Total Capacity (kW)

Capacity Index	Outdoor Air Temp. ( °C )		Indoor temperature ( °C,DB )				
			16(°C,DB)	18(°C,DB)	20(°C,DB)	22(°C,DB)	24(°C,DB)
			TC	TC	TC	TC	TC
	DB	WB	kW	kW	kW	kW	kW
140	7.0	6.0	16.50	16.20	16.00	14.80	13.50
280	7.0	6.0	35.70	33.70	31.50	30.40	29.50

### NOTE

- The performance table shows the average value of each conditions.

# 4. Dimensional Drawing

PAC

AM140HEPDKG/EU

Units : mm [inches]

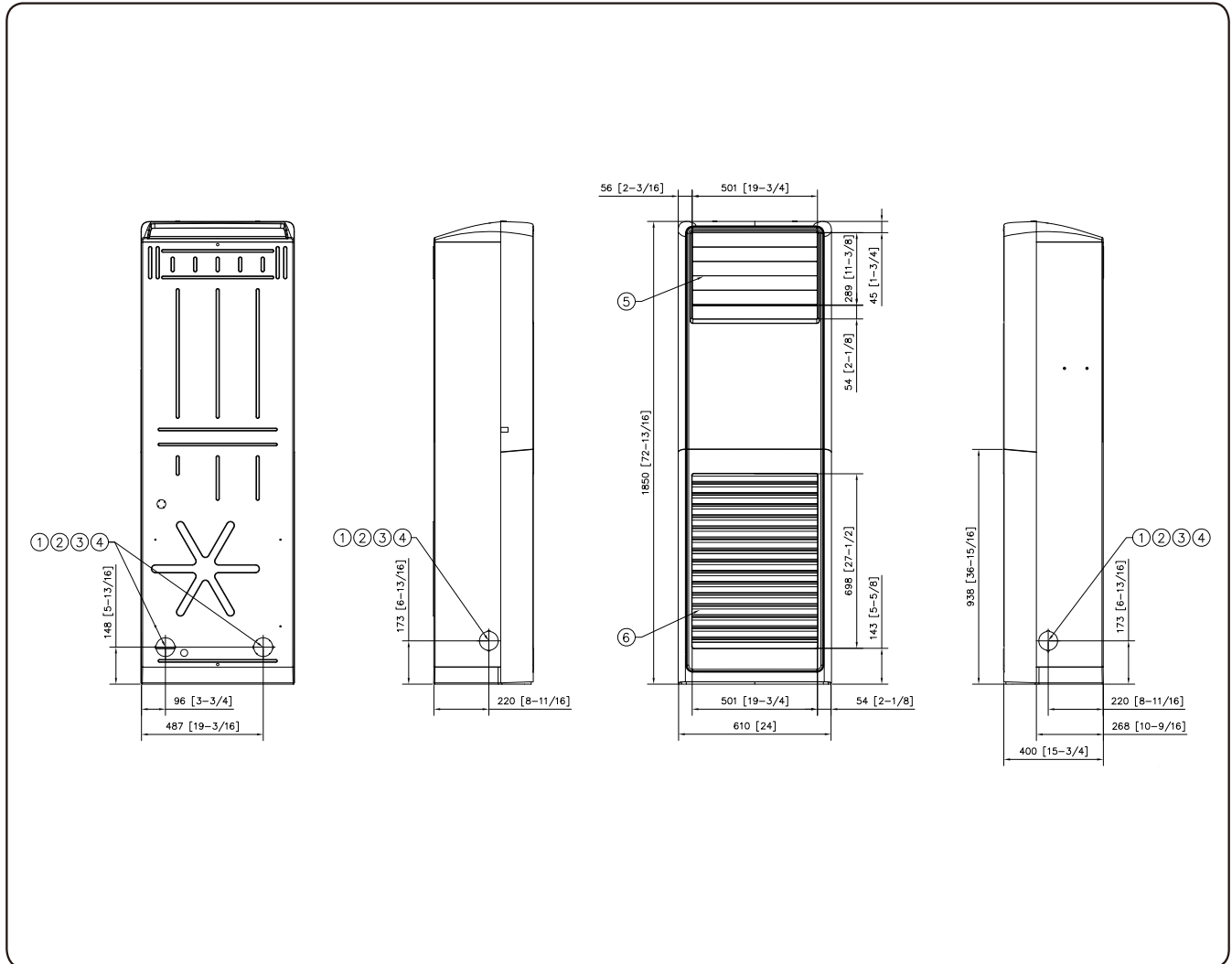

No.	Name	Description
1	Gas pipe connection	Φ15.88 [5/8]
2	Liquid pipe connection	Φ9.52 [3/8]
3	Drain pipe connection	VP25 (OD 32, ID 25)
4	Power supply & Communication wiring conduit	-
5	Air outlet blade	-
6	Air inlet grille	-

# 4. Dimensional Drawing

PAC

AM280HEPDKG/EU

Units : mm [inches]

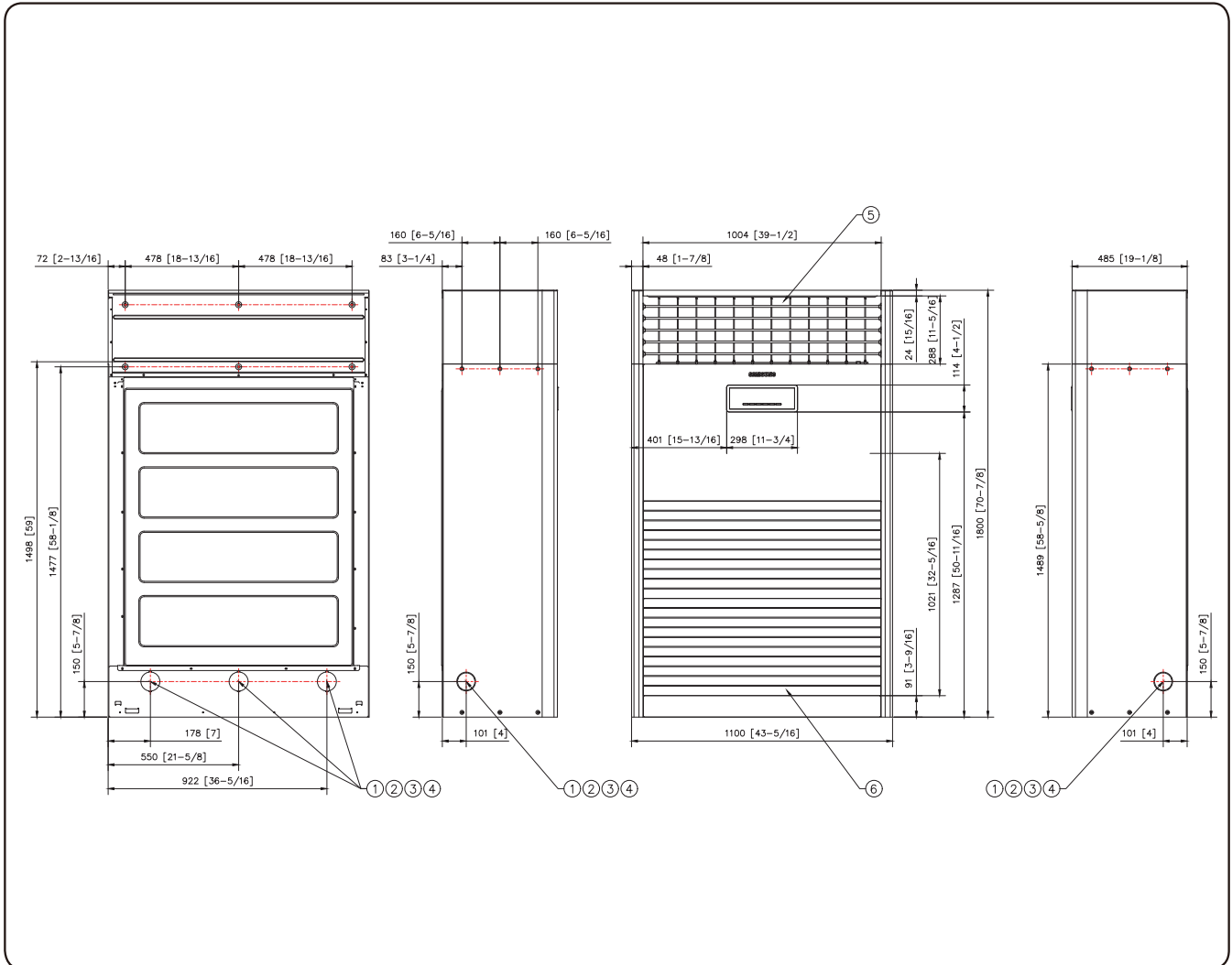

No.	Name	Description
1	Gas pipe connection	Ø22.22 [7/8]
2	Liquid pipe connection	Ø9.52 [3/8]
3	Drain pipe connection	VP25 (OD 32, ID 25)
4	Power supply & Communication wiring conduit	-
5	Air outlet blade	-
6	Air inlet grille	-

# 5. Center of Gravity

PAC

AM140HEPDKG/EU

Units : mm [inches]

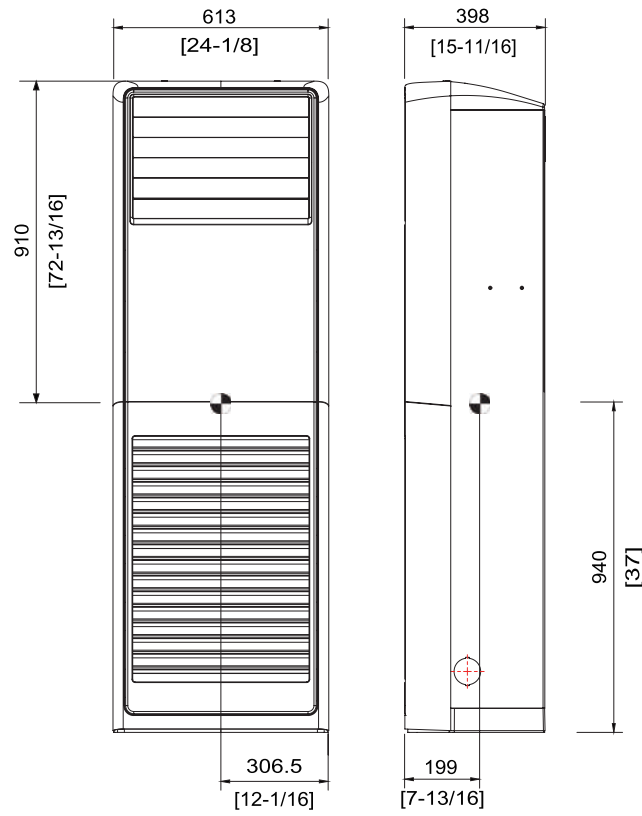

# 5. Center of Gravity

PAC

AM280HEPDKG/EU

Units : mm [inches]

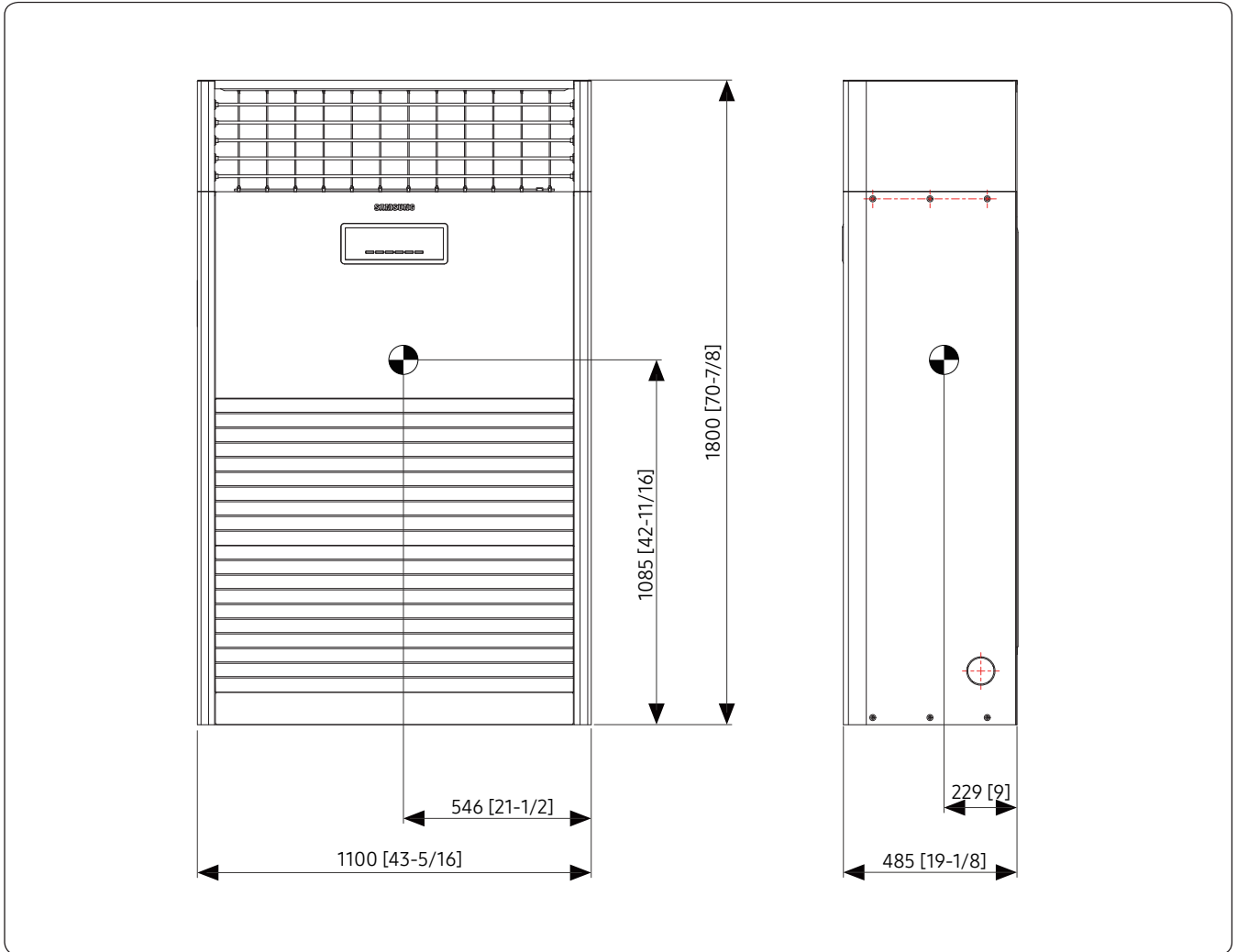

# 6. Electrical Wiring Diagram

PAC

AM140HEPDKG/EU

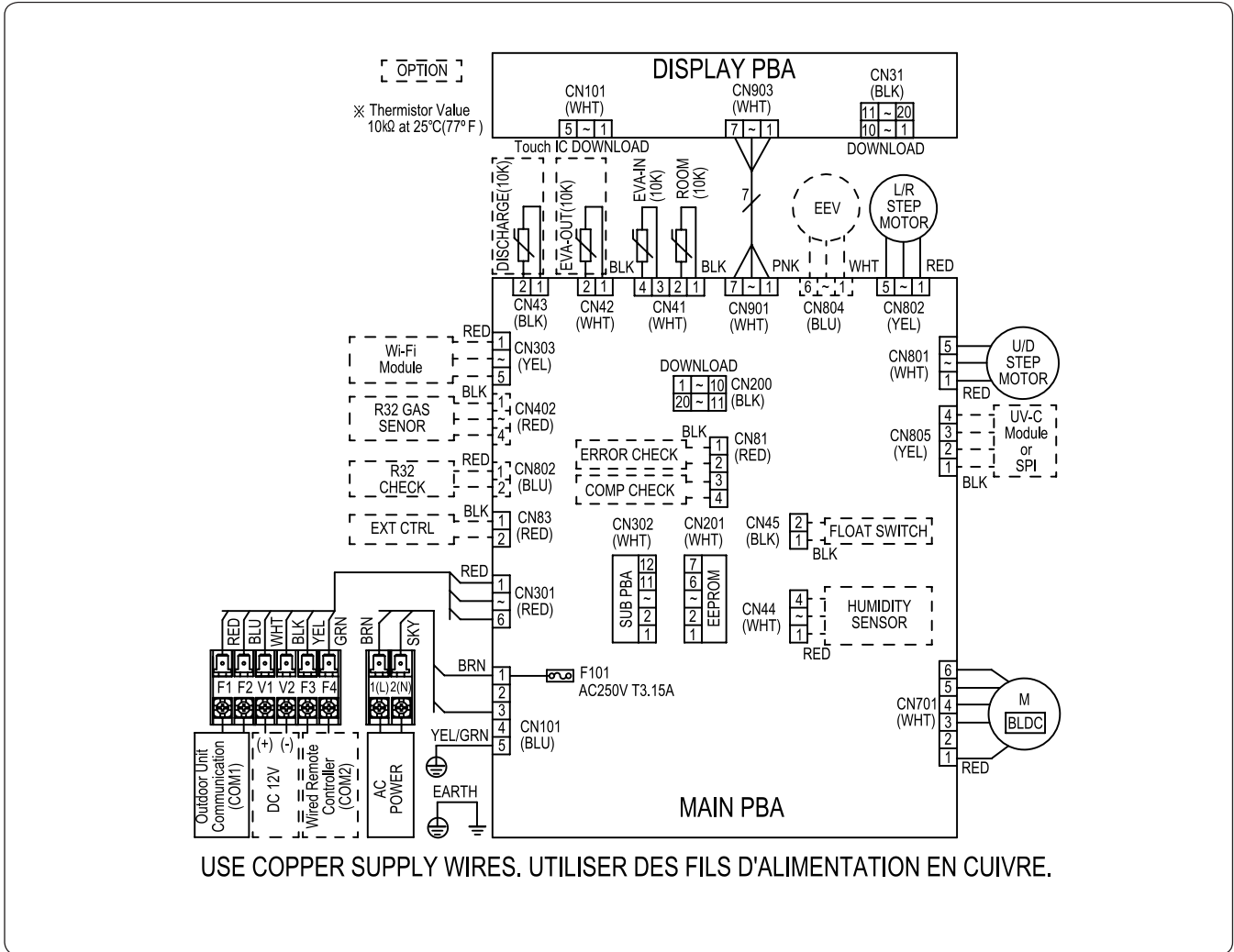

F100	Fuse	ROOM(10K)	Thermistor - Indoor Room
EEV	Electronic Expansion Valve	EVA IN (10K)	Thermistor - IDU heat exchanger In
M-BLDC	Motor for Indoor Fan	EVA OUT (10K)	Thermistor - IDU heat exchanger Out
DISPLAY	Panel LED display	EEPROM	EEPROM SUB PBA
ERROR CHECK	Contact output port for error check	SUB PBA	SUB PBA for wired remote control communication
COMP CHECK	Contact output port for compressor operation check	EXTERNAL CTRL	Input port for external contact control

## NOTE

- This wiring diagram applies only to the Indoor unit.
- Symbols show as follow :  
blk: black, red: red, blu: blue, wht: white, yel: yellow, brn: brown, sky: skyblue, grn: green
- For connection wiring indoor-outdoor transmission F1-F2, indoor-wired remote controller transmission F3-F4.
- Protective earth(screw), : connector, : The wire quantity

# 6. Electrical Wiring Diagram

PAC

AM280HEPDKG/EU

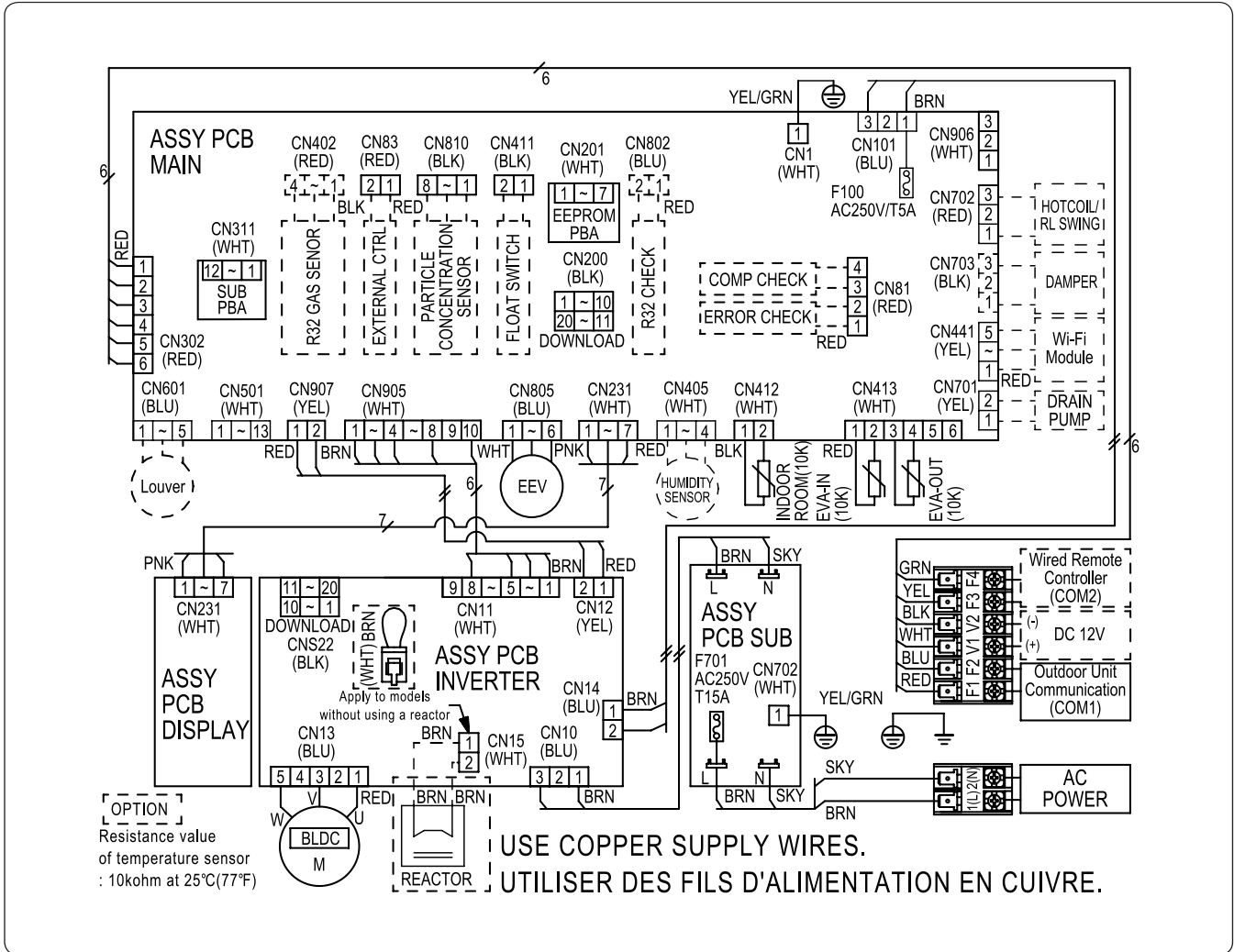

F701	Fuse	INDOOR ROOM(10K)	Thermistor - Indoor Room
F100	Fuse	EVA IN (10K)	Thermistor - IDU heat exchanger In
EEV	Electronic Expansion Valve	EVA OUT (10K)	Thermistor - IDU heat exchanger Out
M-BLDC	Motor for Indoor Fan	EEPROM	EEPROM SUB PBA
DISPLAY	Panel LED display	SUB PBA	SUB PBA for wired remote control communication
ERROR CHECK	Contact output port for error check	VENTILATOR	Contact output port for Ventilator control
COMP CHECK	Contact output port for compressor operation check	EXTERNAL CTRL	Input port for external contact control

## NOTE

- This wiring diagram applies only to the Indoor unit.
- Symbols show as follow :  
blk: black, red: red, blu: blue, wht: white, yel: yellow, brn: brown, sky: skyblue, grn: green
- For connection wiring indoor-outdoor transmission F1-F2, indoor-wired remote controller transmission F3-F4.
- Protective earth(screw), : connector, : The wire quantity

# 7. Sound Data

PAC

## Sound Pressure level

Unit: dB(A)

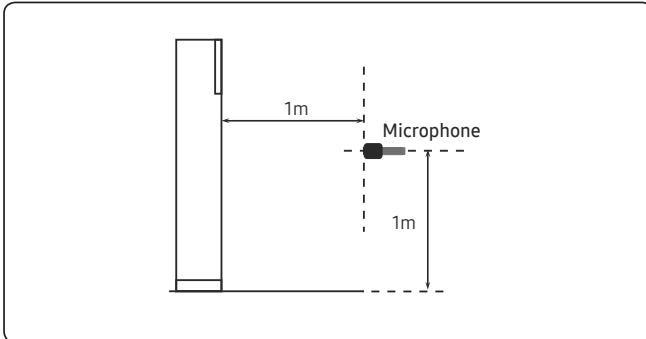

Model	High	Mid	Low
AM140HEPDKG/EU	54	TBD	47
AM280HEPDKG/EU	58	56	54

- NR Curve

1) AM140HEPDKG/EU

2) AM280HEPDKG/EU

# TBD

### NOTE

- Specifications may be subject to change without prior notice.
- Sound pressure Level
  - Sound pressure level is obtained in an anechoic room.
  - Sound pressure level is a relative value, depending on the distance and acoustic environment.
  - Sound pressure level may differ depending on operation condition.
  - dBA = A weighted sound pressure level
  - Reference acoustic pressure 0 dB = 20 $\mu$ Pa

# 7. Sound Data

---

PAC

---

## Sound Power level

 NOTE

Unit: dB(A)

- Specifications may be subject to change without prior notice
  - Sound power level is an absolute value that a sound source generates.
  - dBA = A-weighted sound power level.
  - Reference power : 1pW.
  - Measured according to ISO 3741.

Model	Power
AM140HEPDKG/EU	TBD
AM280HEPDKG/EU	74

- NR Curve

1) AM140HEPDKG/EU

2) AM280HEPDKG/EU

TBD

# 8. Temperature and air flow distribution

PAC

## AM140HEPDKG/EU

- Cooling air velocity distribution

(Discharge angle : 10°)

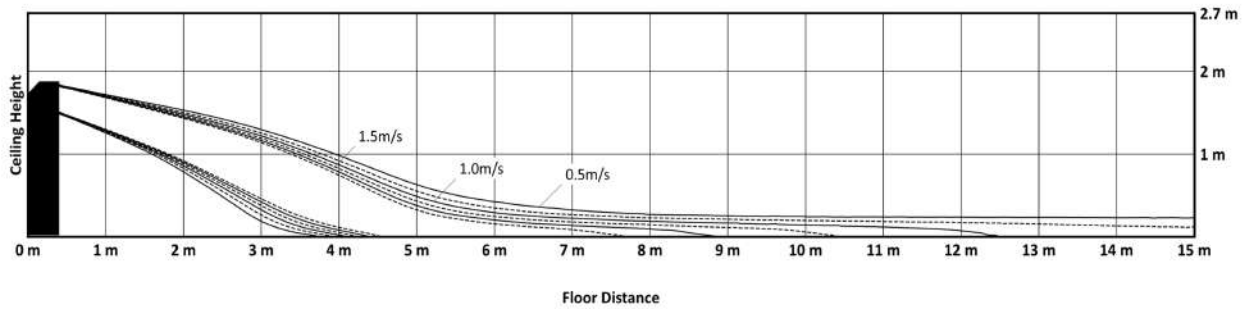

- Cooling temperature distribution

(Discharge angle : 10°)

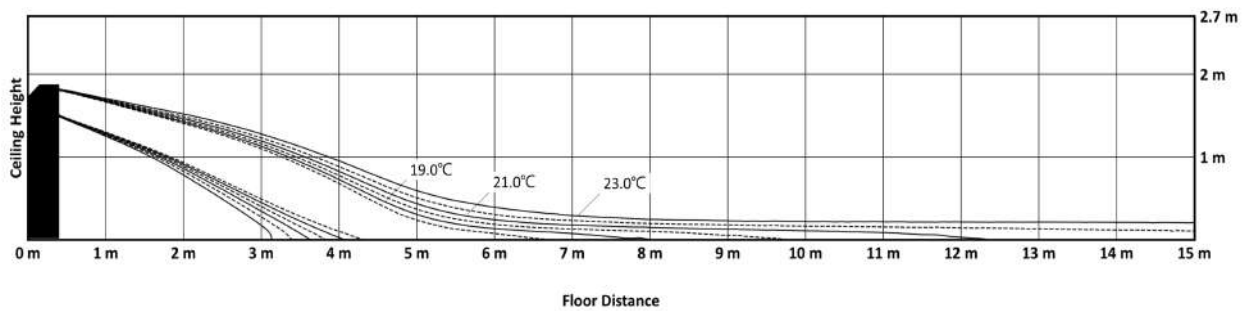

- Heating air velocity distribution

(Discharge angle : 20°)

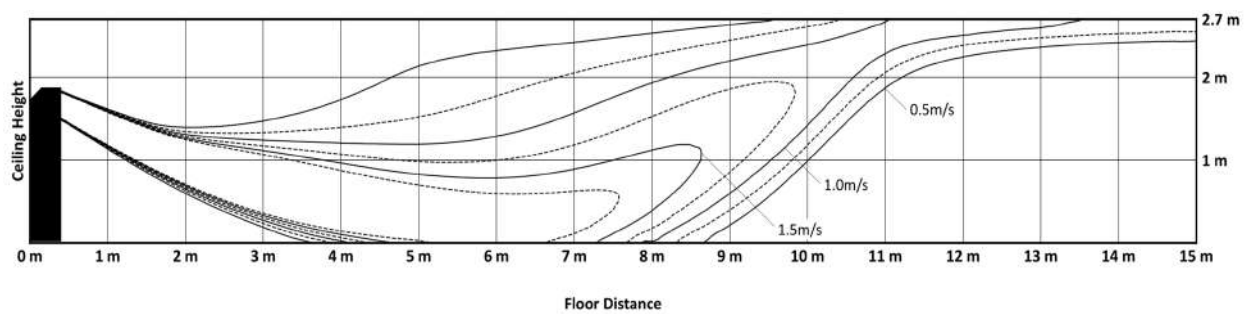

- Heating temperature distribution

(Discharge angle : 20°)

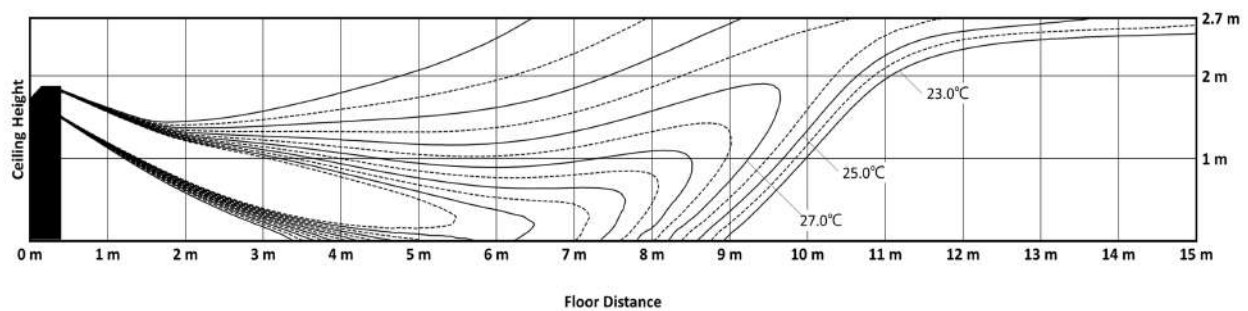

# 8. Temperature and air flow distribution

PAC

## AM280HEPDKG/EU

- Cooling air velocity distribution

(Discharge angle : 10°)

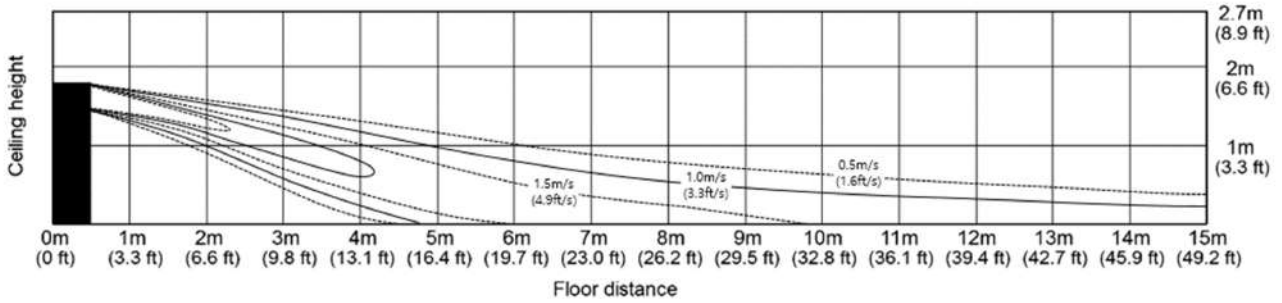

- Cooling temperature distribution

(Discharge angle : 10°)

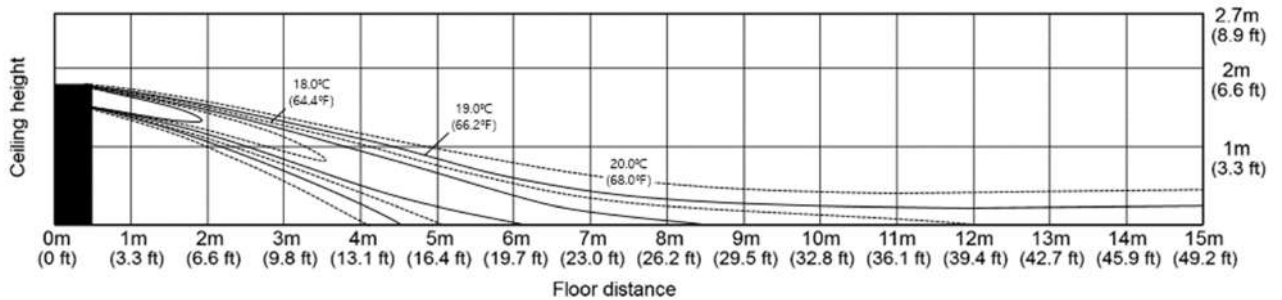

- Heating air velocity distribution

(Discharge angle : 8°)

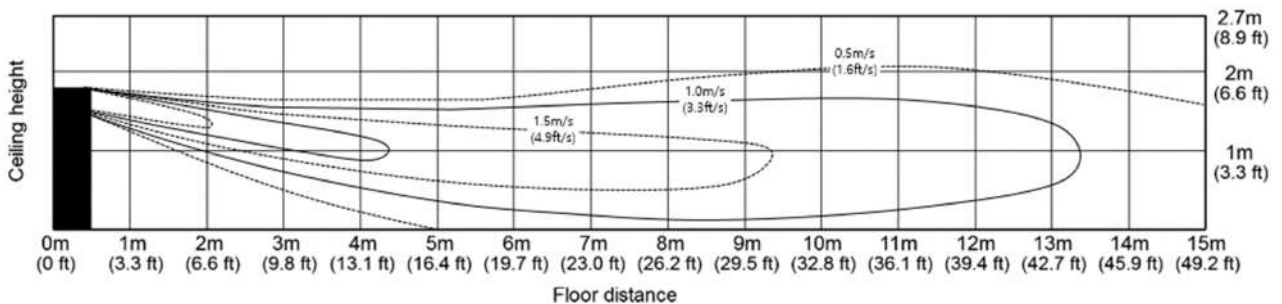

- Heating temperature distribution

(Discharge angle : 8°)

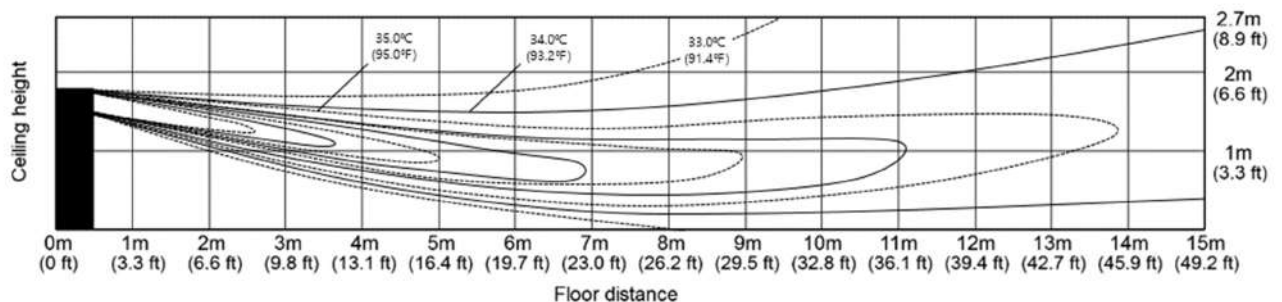

# 9. Piping Diagram

PAC

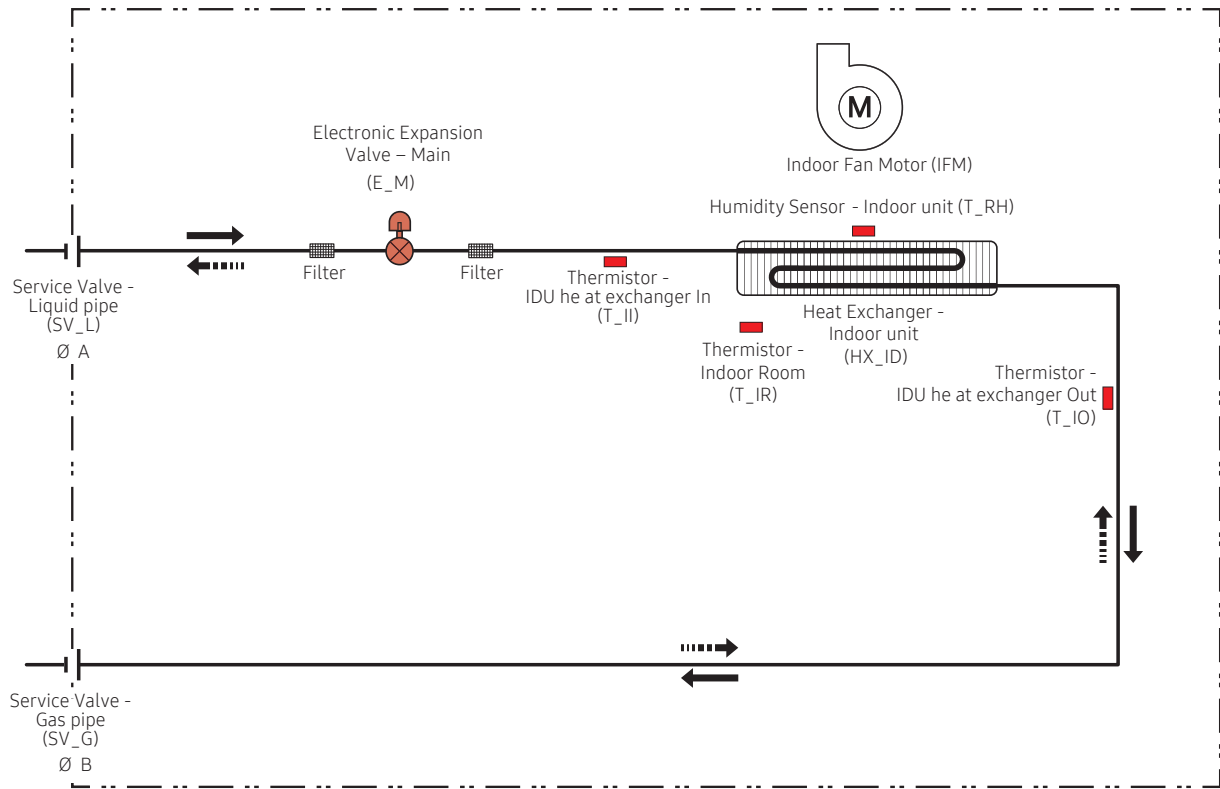

Refrigerant flow	
Cooling	Heating

2025.06  
Ver. 2.0

**Samsung Electronics Co., LTD.**

Head Office (Suwon Korea) 129, Samsung-Ro, Yeongtong-Gu, Suwon City, Gyeonggi-Do, Korea 16677

Website : [www.samsung.com](http://www.samsung.com), <https://partnerhub.samsung.com> Email : [airconditioner@samsung.com](mailto:airconditioner@samsung.com)

Images and data in this book may subject to change without prior notice.